



# V3x Series Encoder Hardware Manual

V31, V32

2014/12/23



**ACTi**  
Connecting Vision

# Table of Contents

## **Precautions ..... 3**

---

Safety Instructions .....	5
---------------------------	---

## **Introduction ..... 6**

---

The List of Models .....	6
Package Contents.....	7
Physical Description .....	8
V31 Overview.....	8
V32 Overview.....	10
Mounting the Device.....	13

## **Making Connections..... 14**

---

Connection Architecture .....	14
Connecting to Power.....	14
Connecting the Analog Camera .....	15
Connect to Network.....	15
Connecting the Digital Input/Output Devices (Optional).....	16
DI/DO Connection Specifications.....	19
Connecting Audio Devices (Optional).....	21
Connecting an Audio Input Device .....	21
Connecting an Audio Output Device .....	22
Connecting a Serial Device (Optional).....	23

## **Accessing the Encoder ..... 25**

---

Configure the IP Addresses .....	25
Access the Encoder .....	29

# Precautions

## **Read these instructions**

You should read all the safety and operating instructions before using this product.

## **Heed all warnings**

You must adhere to all the warnings on the product and in the instruction manual. Failure to follow the safety instruction given may directly endanger people, cause damage to the system or to other equipment.

## **Servicing**

Do not attempt to service this video device yourself as opening or removing covers may expose you to dangerous voltage or other hazards. Refer all servicing to qualified service personnel.

## **Trademarks**

All names used in this manual are probably registered trademarks of respective companies.

## **Liability**

Every reasonable care has been taken during the writing of this manual. Please inform your local office if you find any inaccuracies or omissions. We cannot be held responsible for any typographical or technical errors and reserve the right to make changes to the product and manuals without prior notice.

### Federal Communications Commission Statement



This equipment has been tested and found to comply with the limits for a class B digital device, pursuant to Part 15 of the FCC Rules. These limits are designed to provide reasonable protection against harmful interference in a residential installation. This equipment generates, uses, and can radiate radio frequency energy and, if not installed and used in accordance with the instructions, may cause harmful interference to radio communications. However, there is no guarantee that interference will not occur in a particular installation. If this equipment does cause harmful interference to radio or television reception, which can be determined by turning the equipment off and on, the user is encouraged to try to correct the interference by one or more of the following measures:

- Reorient or relocate the receiving antenna.
- Increase the separation between the equipment and receiver.
- Connect the equipment into an outlet on a circuit different from that to which the receiver is connected.
- Consult the dealer or an experienced radio/TV technician for help.

**Warning:** Changes or modifications to the equipment that are not expressly approved by the responsible party for compliance could void the user's authority to operate the equipment.

### European Community Compliance Statement



This product has been tested and found to comply with the limits for Class B Information Technology Equipment according to European Standard EN 55022 and EN 55024. In a domestic environment, this product may cause radio interference in which cause the user may be required to take adequate measures.

## Safety Instructions

---

### **Cleaning**

Disconnect this video product from the power supply before cleaning.

### **Attachments**

Do not use attachments not recommended by the video product manufacturer as they may cause hazards.

### **Do not use accessories not recommended by the manufacturer**

Only install this device in a dry place protected from weather

### **Servicing**

Do not attempt to service this video product yourself. Refer all servicing to qualified service personnel.

### **Damage Requiring service**

Disconnect this video product from the power supply immediately and refer servicing to qualified service personnel under the following conditions.

- 1) When the power-supply cord or plug is damaged
- 2) If liquid has been spilled, or objects have fallen into the video product.
- 3) If the inner parts of video product have been directly exposed to rain or water.
- 4) If the video product does not operate normally by following the operating Instructions in this manual. Adjust only those controls that are covered by the instruction manual, as an improper adjustment of other controls may result in damage, and will often require extensive work by a qualified technician to restore the video product to its normal operation.

### **Safety Check**



Upon completion of any service or repairs to this video product, ask the service technician to perform safety checks to determine if the video product is in proper operating condition.

# Introduction

## The List of Models

---

This hardware manual contains the following models:

V31		8-Channel 960H/D1 H.264 Rackmount Video Encoder
V32		16-Channel 960H/D1 H.264 Rackmount Video Encoder

## Package Contents

<p>Video Encoder</p> 	<p>Power Cord</p> 	<p>Socket Converter</p> 
<p>Rack Mount Ears</p> 	<p>Screw Pack</p> 	<p>Serial Communication &amp; Audio Output Terminal Blocks</p> 
<p>Digital Input/Output &amp; Audio Input Terminal Blocks (for V31)</p> 	<p>Digital Input/Output &amp; Audio Input Terminal Blocks (for V32)</p> 	<p>Quick Installation Guide</p> 
<p>Warranty Card</p>		
		

**NOTE:** The above pictures are for reference only; actual items may slightly vary.

## Physical Description

### V31 Overview



Item		Description
1	Power LED	Lights up when the device is powered on.
2	Serial Communication 1 Activity LED	Lights up to when a serial device is connected to the <b>RS-422/RS-485 Port 1</b> .
3	Serial Communication 2 Activity LED	Lights up to when a serial device is connected to the <b>RS-422/RS-485 Port 2</b> .
4	Video Input LEDs (1~8)	The LED lights up when an analog camera is connected to its corresponding video input connector.
5	Memory Card Slot	Insert a memory card (not included) into the slot for local recording purposes. <b>NOTE:</b> Supports microSDHC and microSDXC cards. Card not included in the package.
6	Video Input Connectors (1~8)	Connects an analog camera through BNC connection. See <a href="#">Connecting the Analog Camera</a> on page 15 for more information. <b>NOTE:</b> Video cable with BNC connector not included in the package.
7	Reset Button	Use to restore the factory default settings, including the administrator's password. To reset the encoder, press and hold the Reset button using a pointed object (e.g. pen), for 5 seconds or until the Power LED goes off.



	Item	Description
8	Ethernet Port	Connects to the network using a standard Ethernet cable.
9	AC Power Input	Use this connector to connect the bundled power cord. See <a href="#">Connecting to Power</a> on page 14 for more information.
10	Power Switch	Press the switch to turn the encoder on or off.
11	Digital Input / Output Connector (1~8)	Connects to digital input or output devices, such as an alarm trigger, panic button, etc. Digital Input (DI) and Digital Output (DO) devices are used in applications like motion detection, event triggering, alarm notifications, etc. See <a href="#">Connecting the Digital Input/Output Devices (Optional)</a> on page 16 for more information.
12	Audio Input Connectors (1~8)	Connects to audio input devices, such as a microphone with built-in amplifier, etc. See <a href="#">Connecting an Audio Input Device</a> on page 21 for more information. <b>NOTE:</b> The microphone must have a built-in amplifier. Connecting an ordinary microphone will dwarf sounds and will result in inaudible recording.
13	RS-422 / RS-485 Port (1~2)	Connects to an analog device via RS-485 / RS-422 serial communication to control encoder functions like pan-tilt, zoom, etc. See <a href="#">Connecting a Serial Device (Optional)</a> on page 23 for more information.
14	Audio Output Connector	Connects to an audio output device, such as a powered speaker. See <a href="#">Connecting an Audio Output Device</a> on page 22 for more information.

V32 Overview



Item		Description
1	Power LED	Lights up when the device is powered on.
2	Serial Communication 1 Activity LED	Lights up to when a serial device is connected to the <b>RS-422/RS-485 Port 1</b> .
3	Serial Communication 2 Activity LED	Lights up to when a serial device is connected to the <b>RS-422/RS-485 Port 2</b> .
4	Video Input LEDs (1~16)	The LED lights up when an analog camera is connected to its corresponding video input connector.
5	Memory Card Slot	Insert a memory card (not included) into the slot for local recording purposes. <b>NOTE:</b> Supports microSDHC and microSDXC cards. Card not included in the package.
6	Video Input Connectors (1~16)	Connects an analog camera through BNC connection. See <a href="#">Connecting the Analog Camera</a> on page 15 for more information. <b>NOTE:</b> Video cable with BNC connector not included in the package.
7	Reset Button	Use to restore the factory default settings, including the administrator’s password. To reset the encoder, press and hold the Reset button using a pointed object (e.g. pen), for 5 seconds or until the Power LED goes off.

Item		Description
8	Ethernet Port	Connects to the network using a standard Ethernet cable.
9	AC Power Input	Use this connector to connect the bundled power cord. See <a href="#">Connecting to Power</a> on page 14 for more information.
10	Power Switch	Press the switch to turn the encoder on or off.
11	Digital Input / Output Connector (9~16)	Connects to digital input or output devices, such as an alarm trigger, panic button, etc. Digital Input (DI) and Digital Output (DO) devices are used in applications like motion detection, event triggering, alarm notifications, etc. See <a href="#">Connecting the Digital Input/Output Devices (Optional)</a> on page 16 for more information.
12	Audio Input Connectors (9~16)	Connects to audio input devices, such as a microphone with built-in amplifier, etc. See <a href="#">Connecting an Audio Input Device</a> on page 21 for more information. <b>NOTE:</b> The microphone must have a built-in amplifier. Connecting an ordinary microphone will dwarf sounds and will result in inaudible recording.
13	Digital Input / Output Connector (1~8)	Connects to digital input or output devices, such as an alarm trigger, panic button, etc. Digital Input (DI) and Digital Output (DO) devices are used in applications like motion detection, event triggering, alarm notifications, etc. See <a href="#">Connecting the Digital Input/Output Devices (Optional)</a> on page 16 for more information.
14	Audio Input Connectors (1~8)	Connects to audio input devices, such as a microphone with built-in amplifier, etc. <a href="#">Connecting an Audio Input Device</a> on page 21 for more information. <b>NOTE:</b> The microphone must have a built-in amplifier. Connecting an ordinary microphone

Item		Description
		will dwarf sounds and will result in inaudible recording.
<b>15</b>	RS-422 / RS-485 Port (1~2)	Connects to an analog device via RS-485 / RS-422 serial communication to control encoder functions like pan-tilt, zoom, etc. See <a href="#">Connecting a Serial Device (Optional)</a> on page 23 for more information.
<b>16</b>	Audio Output Connector	Connects to an audio output device, such as a powered speaker. See <a href="#">Connecting an Audio Output Device</a> on page 22 for more information.

## Mounting the Device

---

Mount the device on a 19" rack.

1. Attach the ears on each side of the encoder using the bundled screws.



2. Secure the encoder onto the rack using four (4) screws.



**NOTE:** Use the screws that came with the rack; or, purchase applicable screws for rack mounting.

# Making Connections

This section describes how to connect the encoder to the power, network and analog cameras. It also describes the procedures in preparing the external devices that you can connect to the encoder. The encoder supports Digital Input and Output (DI/DO), Audio Input and Output devices, as well as Serial Port Communication via RS-485 / RS-422 protocol using the bundled terminal blocks. The use of these devices, however, is optional.

## Connection Architecture

The diagram below is an example of the basic connection within a local network.



## Connecting to Power

Plug the bundled power cord to the **AC Power Input** port of the encoder. Then, press the Power switch to turn on the encoder.

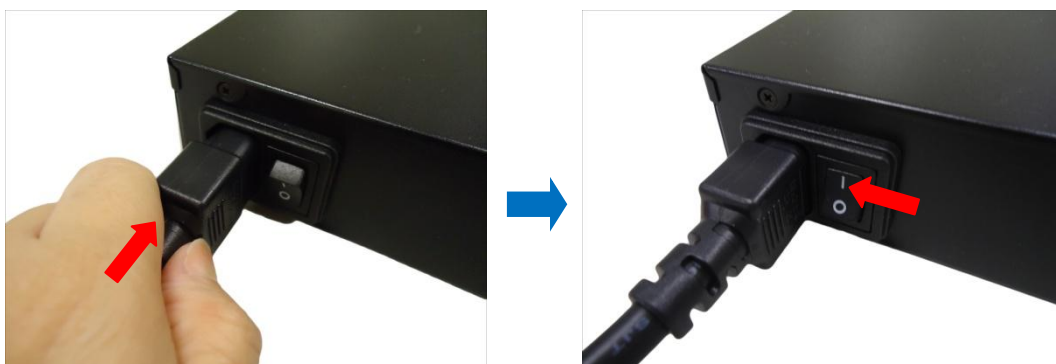

**NOTE:** Use only the bundled power cord that came with the encoder.

## Connecting the Analog Camera

---

Connect the analog camera to one of the **Video Input** ports of the encoder using a video cable with BNC connectors.

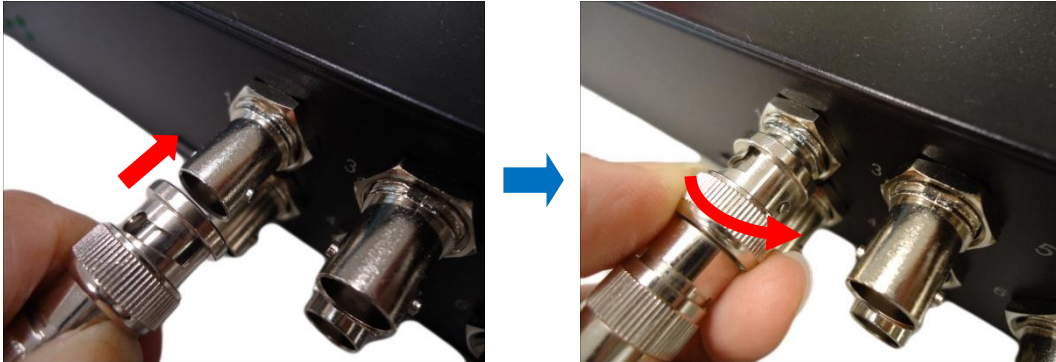

**NOTE:** The video cable is not included in the package.

## Connect to Network

---

Connect one end of a network cable to the **Ethernet** port of the encoder and the other end to the network.



## Connecting the Digital Input/Output Devices (Optional)

Depending on your surveillance needs, you may connect digital input / output devices to your encoder.

Digital Input (DI) devices can be used to notify the encoder about an activity in the camera on the encoder site. DI can be triggers of events. For example, you can connect a “panic button” to the encoder; as such when the panic button is pressed, the alarm signal will be sent through the encoder. Other common DI device applications are emergency button, smoke detector, passive infrared sensor, etc.

Digital Output (DO) devices are external devices that are activated by the encoder upon an event within the encoder (e.g. video connection is lost, etc.) or triggered by motion in the camera site among others. For example, you can connect an “alarm horn” to the encoder; as such when an event occurs on the camera side (e.g. detected intruder), the alarm horn will sound. Other common DO device applications are motion-triggered lights, electric fence, magnetic door locks, etc.

The digital input and output pins of V31 / V32 are configurable; meaning, either a digital input or digital output device can be connected to a particular DIO pin. Once connected, the pin must be defined through the Web Configurator (see the Encoder Firmware Manual for more information). V31 has 8 DIO ports and V32 has 16 DIO ports.

Four (4) DIO ports share the same terminal block with four (4) audio input ports. For example, DIO port 1, 3, 5, and 7 are on the same terminal block with audio input ports 1, 3, 5, and 7. See samples below:

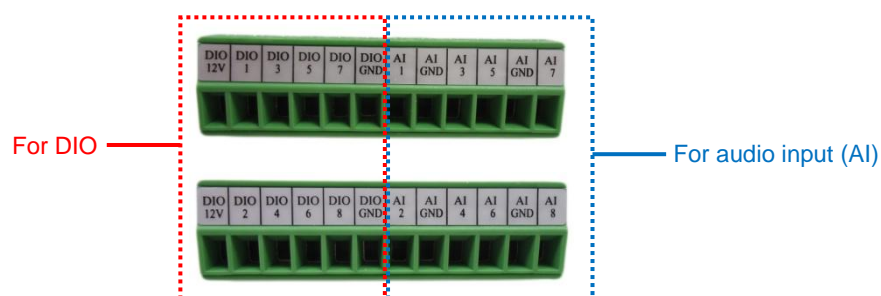



1. Loosen the screw of the pin and insert the wire through the pin slot.

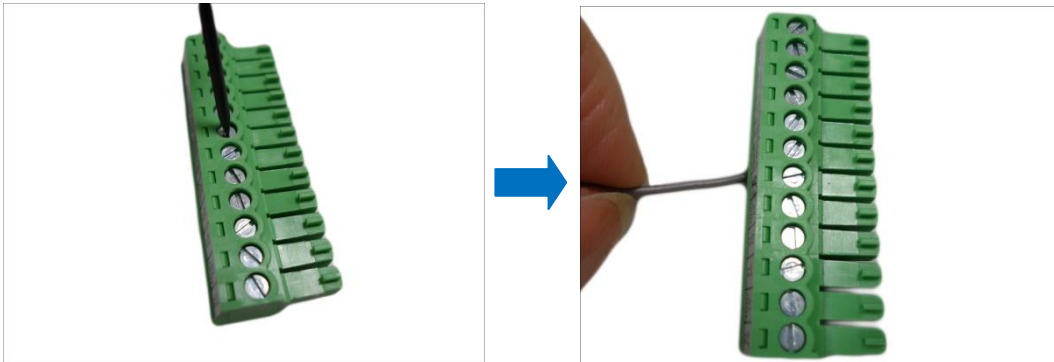

2. To connect digital input / output devices (DI/DO), map the pins to one of the pin combinations below:

Device	Pin Label	Mapping Instructions
Digital Output (DO)	DIO (port number)	Connect the wires of the output device to a <b>DIO</b> and <b>DIO 12V</b> .
	DIO 12V	
Digital Input (DI)	DIO (port number)	Connect the wires of the input device to <b>DI</b> and <b>DIO GND</b> .
	DIO GND	

**NOTE:** For every digital output device, a wire must also be mapped to the **12V** pin. Same with for every digital input device, a wire must also be mapped to the **GND** pin. The **GND** and **12V** pins may be mapped with more than one device.

3. Tighten the screws to secure the wires within the pin slot.



4. Connect the terminal block to the corresponding DIO connector of the encoder.

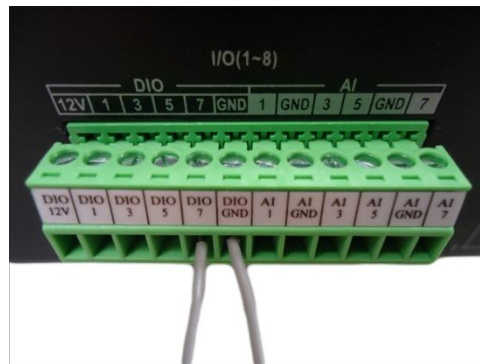

5. Configure the DIO ports in Web Configurator (see the Encoder Firmware Manual for more information).

## DI/DO Connection Specifications

The table below shows the DI/DO connection specifications:

Device			
DI	Connection design		TTL - compatible logic levels
	Voltage	To trigger (low)	Logic level 0: 0V ~ 0.4V
		Normal (high)	Logic level 1: 3.1V ~ 30V
	Current		10mA ~ 100mA
DO	Connection design		Transistor (Open Collector)
	Voltage & Current		< 24V DC, < 50mA

### Typical Connection

Based on these specifications, if the DI device has a voltage of 0V ~ 30V or the DO device has a voltage of < 24V (< 50mA), then the encoder can supply internal power to these devices and there is no need to connect the DI/DO device to an external power source.

Use the **GND** and **DIO** pins to connect a DI device and use the **DIO** and **12V** pins to connect a DO device. See wiring scheme below:

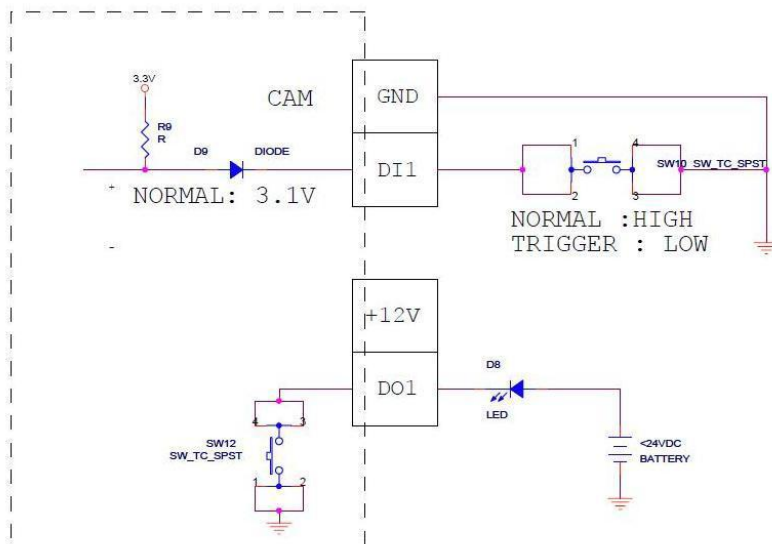

### High Voltage DO Device Connection

Even though the encoder provides 12V power, this may not be enough for some high voltage DO devices, such as a ceiling light or a motor that opens or closes a gate. In this case, there is a need to connect an external relay. See wiring scheme below:

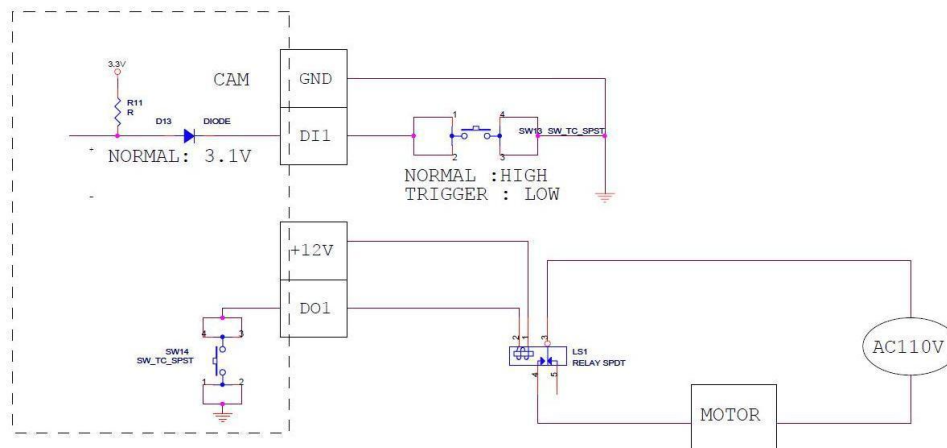

Note that when choosing an appropriate relay, please refer to its specifications and make sure they match the above design. The triggering circuit voltage has to be around 12V DC and the switch-controlled circuit voltage has to match the external power supply (e.g. 110V AC or 220V AC).

The illustration below is a graphic example of connecting a relay to a high voltage DO device.

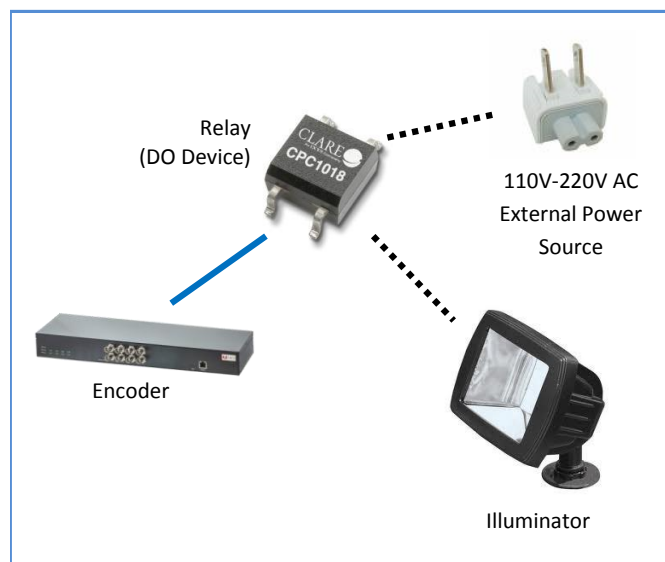

**NOTE:** For more information on DI/DO connections, please refer to the Knowledge Base article [All about Digital Input and Digital Output](http://www.acti.com/kb/detail.asp?KB_ID=KB20091230001) downloadable from the link below ([http://www.acti.com/kb/detail.asp?KB\\_ID=KB20091230001](http://www.acti.com/kb/detail.asp?KB_ID=KB20091230001)).

## Connecting Audio Devices (Optional)

Audio input / output devices, such as an active microphone or speaker can be connected to the encoder using the supplied terminal block.

### Connecting an Audio Input Device

Each video channel has one corresponding audio input channel. The ports are labelled as **AI** followed with a number. This number also corresponds to the video channel. For example, the port labelled as **AI1** is the audio input for video channel 1.

Four (4) audio input ports share the same terminal block with four (4) DIO ports. For example, Audio port 1, 3, 5, and 7 are on the same terminal block with DIO ports 1, 3, 5, and 7. See samples below:

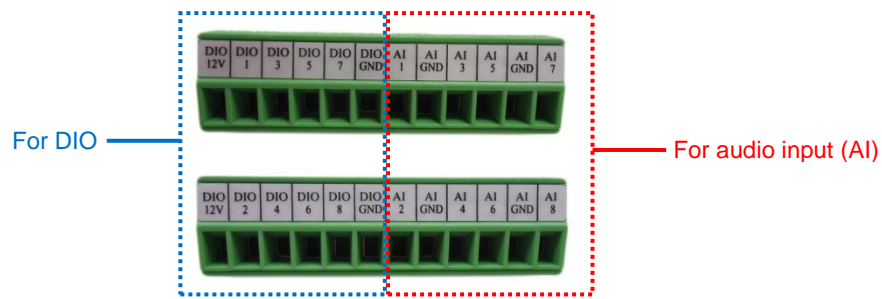

To connect an audio input device, do the following:

1. Loosen the screw of the pin and insert the wire through the pin slot.
2. Connect the wires of the audio input device to **AI** and **AI GND**. The number after AI is the video channel corresponding the audio input device.

**NOTE:**

- The **AI GND** pin may be mapped with more than one audio device.
  - For more information about audio input connections, please refer to the Knowledge Base article [How to Use Audio-in of ACTi Encoders](http://www.acti.com/support/KnowledgeBase/outside/detail.asp?KB_ID=KB20100114003), downloadable from the link below  
[http://www.acti.com/support/KnowledgeBase/outside/detail.asp?KB\\_ID=KB20100114003](http://www.acti.com/support/KnowledgeBase/outside/detail.asp?KB_ID=KB20100114003).
3. Tighten the screws to secure the wires within the pin slot.

## Connecting an Audio Output Device

The encoder has one audio output port that is shared by all the video channels. Any audio that is remotely inputted through the Web Configurator, Network Video Recorder, etc. can be heard through the connected audio output device.

The audio output (AO) port shares the same terminal block with **RS-422 / RS-485 Port 1**.

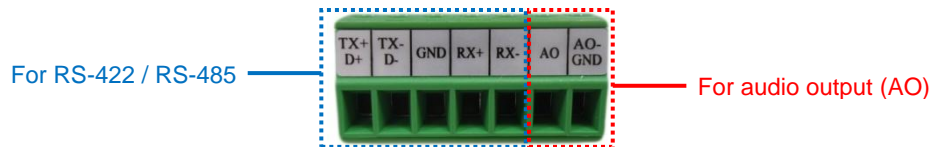

**NOTE:** To ensure optimum performance, use active or powered speakers for audio out.

To connect an audio output device, do the following:

1. Loosen the screw of the pin and insert the wire through the pin slot.
2. Connect the wires of the audio output device to **AO** and **AO-GND**.
3. Tighten the screws to secure the wires within the pin slot.
4. Connect the speaker to a power source.

## Connecting a Serial Device (Optional)

The encoder can be connected to a camera with Pan-Tilt (PT) functions or a PT Scanner (Pan-Tilt Head) using the serial port connector. This allows the encoder to do pan and tilt using protocols, such as Pelco-D, etc. Most PT devices accept protocol commands via RS-485 or RS-422 connection, which are both supported by the encoder. There are two (2) serial communication ports available on the encoder.

Check the connection available on the PT device and connect it to the encoder following the procedures below.

1. Loosen the screw of the pin and insert the wire through the pin slot.
2. Map the wires from the PT device to the encoder using the supplied terminal block according to one of the tables below.

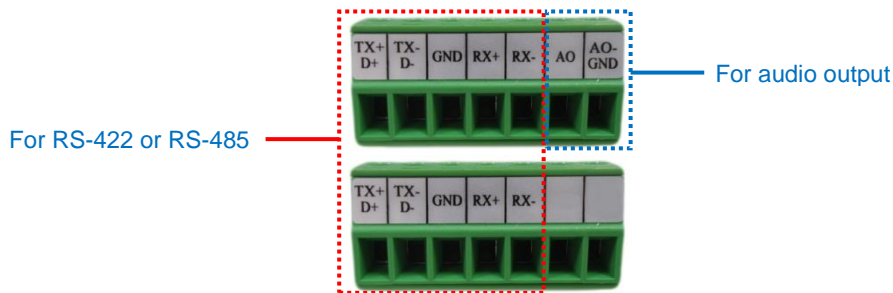

### Via RS-485 Connection

Pin Label	Encoder Pin	PT Device Pin
RX-		-
RX+		-
GND	GROUND PIN	
TX- / D-	TX -	DATA -
TX+ / D+	TX +	DATA +

### Via RS-422 Connection

Pin Label	Encoder Pin	PT Device Pin
Rx-	RX -	TX -
RX+	RX +	TX +
GND	GROUND PIN	
TX -	TX -	RX -
TX +	TX +	RX +

**NOTE:** The pins of the PT Scanner may be labeled differently depending on the location or

country where the scanner is purchased. For example, some devices may have RS-485 **DATA+** pins labeled as “TX+”, “RX+”, “A” or “485+”, etc. Refer to the scanner documentation or contact the manufacturer to verify the corresponding pin labels and ensure proper wiring connection.



**CAUTION:** Incorrect wiring may cause damage to the connected devices.

**DISCLAIMER:** ACTi will not be responsible for any damage caused by improper wiring.

3. Connect a ground wire to the **GND** terminal pin to complete the connection.
4. Tighten the screws to secure the wires within the pin slot.
5. Configure the serial communication settings on the Web Configurator (See Encoder Firmware Manual for more information).

For more information on connecting PT scanners, please refer to the Knowledge Base article:

[Pan and Tilt Scanner for ACTi Zoom Encoders](#)

[http://www.acti.com/support/KnowledgeBase/outside/detail.asp?KB\\_ID=KB20110120001](http://www.acti.com/support/KnowledgeBase/outside/detail.asp?KB_ID=KB20110120001)

available on the website.



# Accessing the Encoder

## Configure the IP Addresses

In order to be able to communicate with the encoder from your PC, both the encoder and the PC have to be within the same network segment. In most cases, it means that they both should have very similar IP addresses, where only the last number of the IP address is different from each other. There are 2 different approaches to IP Address management in Local Area Networks – by DHCP Server or Manually.

### Using DHCP server to assign IP addresses:

If you have connected the computer and the encoder into the network that has a DHCP server running, then you do not need to configure the IP addresses at all – both the encoder and the PC would request a unique IP address from DHCP server automatically. In such case, the encoder will immediately be ready for the access from the PC. The user, however, might not know the IP address of the encoder yet. It is necessary to know the IP address of the encoder in order to be able to access it by using a Web browser.

**The quickest way to discover the encoders in the network** is to use the simplest network search, built in the Windows system – just by pressing the “Network” icon, all the encoders of the local area network will be discovered by Windows thanks to the UPnP function support of our encoders.

In the example below, we successfully the encoder model that we had just connected to the network.

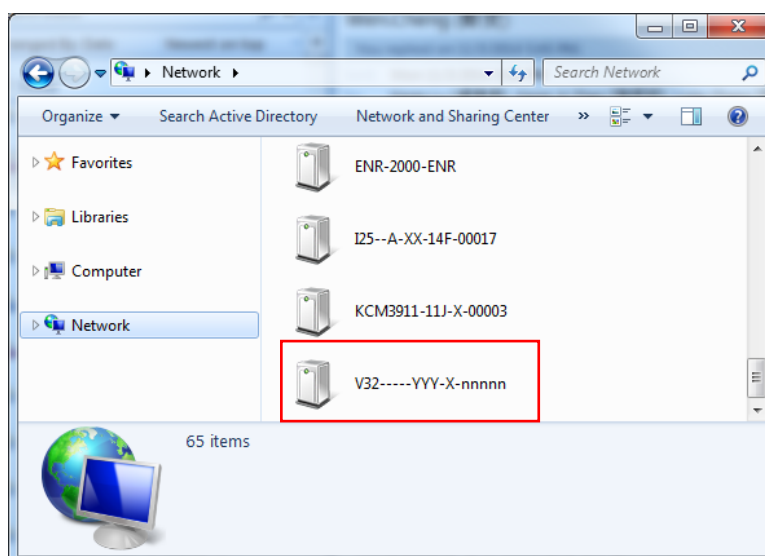

Double-click the mouse button on the encoder model, the default browser of the PC is automatically launched and the IP address of the target encoder is already filled in the address bar of the browser.

If you work with our encoders regularly, then **there is even a better way to discover the encoders in the network** – by using **IP Utility**. The IP Utility is a light software tool that can not only discover the encoders, but also list lots of valuable information, such as IP and MAC addresses, serial numbers, firmware versions, etc, and allows quick configuration of multiple devices at the same time.

The IP Utility can be downloaded for free from [http://www.acti.com/IP\\_Utility](http://www.acti.com/IP_Utility).

With just one click, you can launch the IP Utility and there will be an instant report as follows:

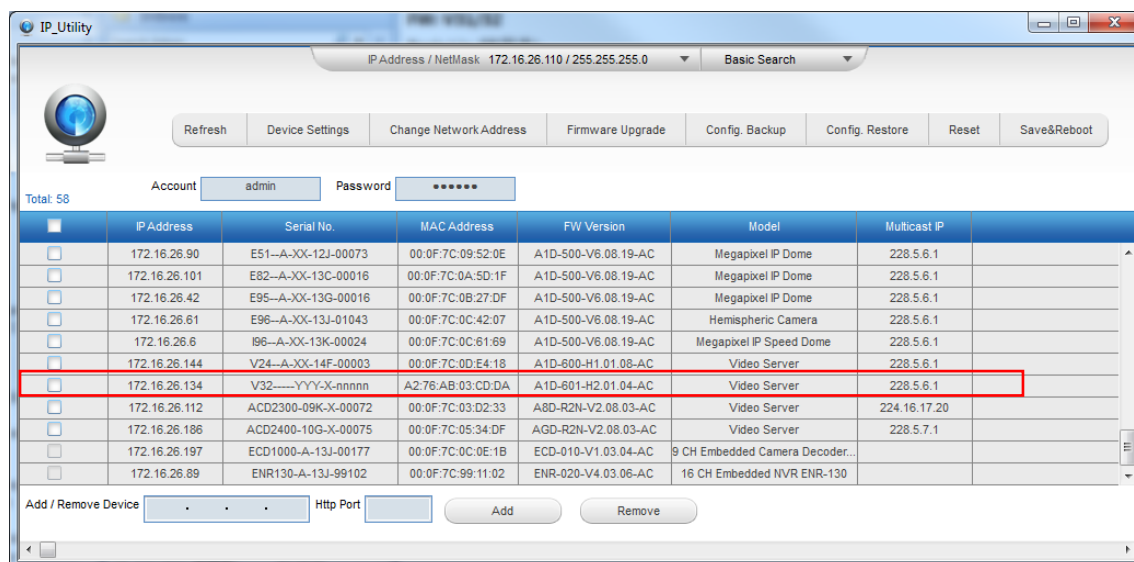

You can quickly notice the encoder model in the list. Click on the IP address to automatically launch the default browser of the PC with the IP address of the target encoder filled in the address bar of the browser already.

## Use the default IP address of a encoder:

If there is no DHCP server in the given network, the user may have to assign the IP addresses to both PC and encoder manually to make sure they are in the same network segment.

When the encoder is plugged into network and it does not detect any DHCP services, it will automatically assign itself a default IP:

**192.168.0.100**

Whereas the default port number would be **80**. In order to access that encoder, the IP address of the PC has to be configured to match the network segment of the encoder.

## Manually adjust the IP address of the PC:

In the following example, based on Windows 7, we will configure the IP address to **192.168.0.99** and set Subnet Mask to **255.255.255.0** by using the steps below:

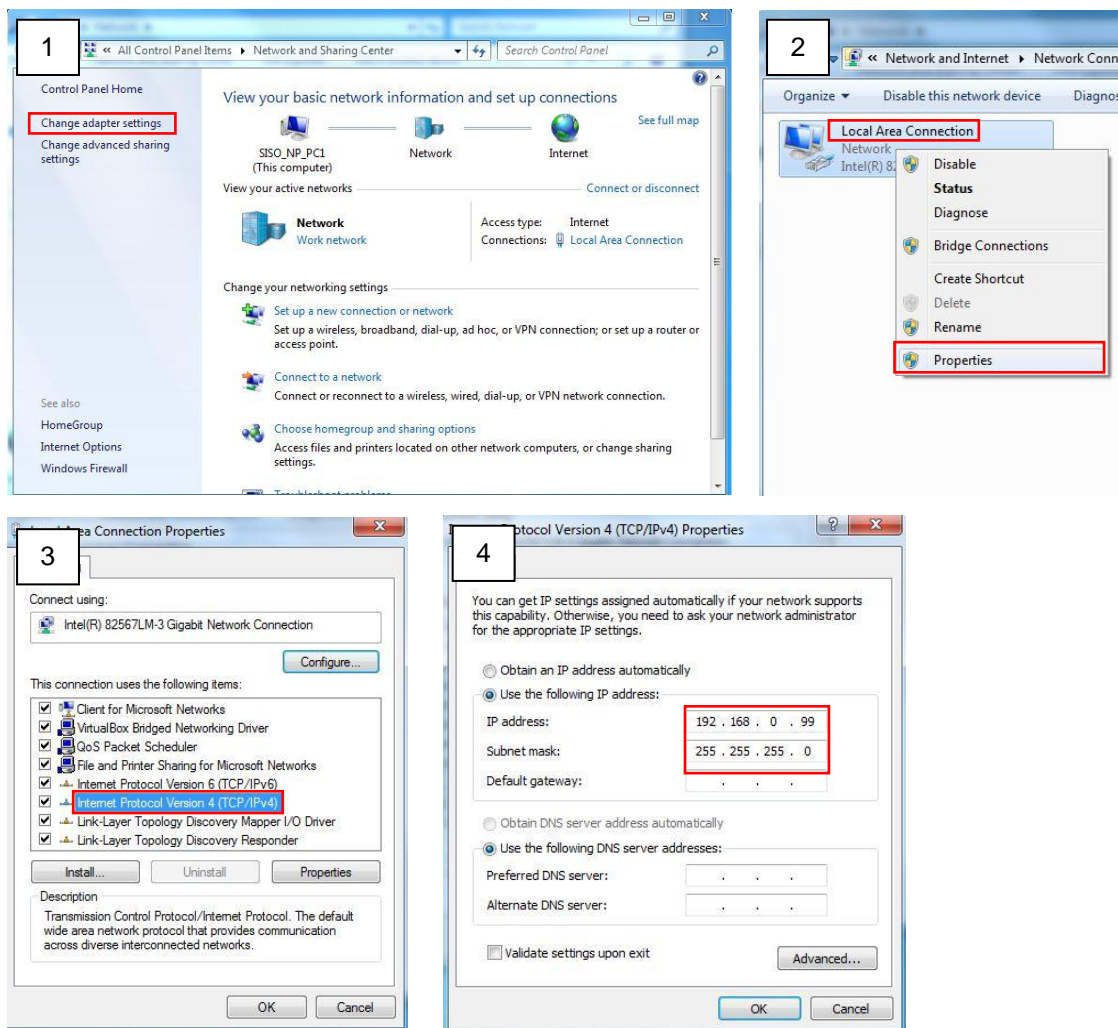

## Manually adjust the IP addresses of multiple encoders:

If there are more than 1 encoder to be used in the same local area network and there is no DHCP server to assign unique IP addresses to each of them, all of the encoders would then have the initial IP address of **192.168.0.100**, which is not a proper situation for network devices – all the IP addresses have to be different from each other. The easiest way to assign encoders the IP addresses is by using **IP Utility**:

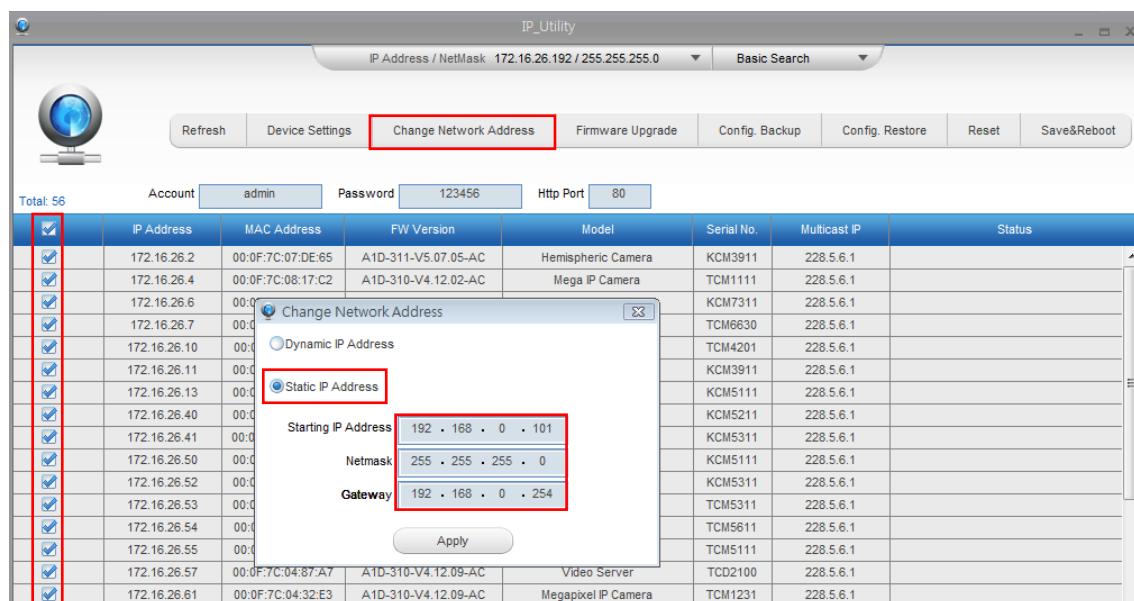

With the procedure shown above, all the encoders will have unique IP addresses, starting from 192.168.0.101. In case there are 20 encoders selected, the last one of the encoders would have the IP 192.168.0.120.

Later, by pressing the “Refresh” button of the IP Utility, you will be able to see the list of encoders with their new IP addresses.

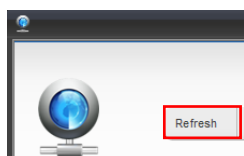

Please note that it is also possible to change the IP addresses manually by using the Web browser. In such case, please plug in only one encoder at a time, and change its IP address by using the Web browser before plugging in the next one. This way, the Web browser will not be confused about two devices having the same IP address at the same time.

## Access the Encoder

Now that the encoder and the PC are both having their unique IP addresses and are under the same network segment, it is possible to use the Web browser of the PC to access the encoder.

You can use **any of the browsers** to access the encoder, however, the full functionality is provided only for **Microsoft Internet Explorer**.

The browser functionality comparison:

Functionality	Internet Explorer	Other browsers
Live Video	Yes	Yes*
Live Video Area Resizable	Yes	No
PTZ Control	Yes	Yes
Capture the snapshot	Yes	Yes
Video overlay based configuration (Motion Detection regions, Privacy Mask regions)	Yes	No
All the other configurations	Yes	Yes

\* When using non-Internet Explorer browsers, free third-party software plug-ins must be installed to the PC first to be able to get the live video feed from the encoder:

Browser	Required Plug-In
Safari	QuickTime ( <a href="http://www.apple.com/quicktime/download/">http://www.apple.com/quicktime/download/</a> )
Other non-Internet Explorer browsers	Basic VLC Media Player ( <a href="http://www.videolan.org">http://www.videolan.org</a> )

**Disclaimer Notice:** The encoder manufacturer does not guarantee the compatibility of its encoders with VLC player or QuickTime – since these are third party softwares. The third party has the right to modify their utility any time which might affect the compatibility. In such cases, please use Internet Explorer browser instead.

When using Internet Explorer browser, the ActiveX control for video stream management will be downloaded from the encoder directly – the user just has to accept the use of such control when prompted so. No other third party utilities are required to be installed in such case.

The following examples in this manual are based on Internet Explorer browser in order to cover all functions of the encoder.

Assuming that the encoder's IP address is **192.168.0.100**, you can access it by opening the Web browser and typing the following address into Web browser's address bar:

**http://192.168.0.100**

Upon successful connection to the encoder, the user interface called **Web Configurator** would appear together with the login page. The HTTP port number was not added behind the IP address since the default HTTP port of the encoder is 80, which can be omitted from the address for convenience.

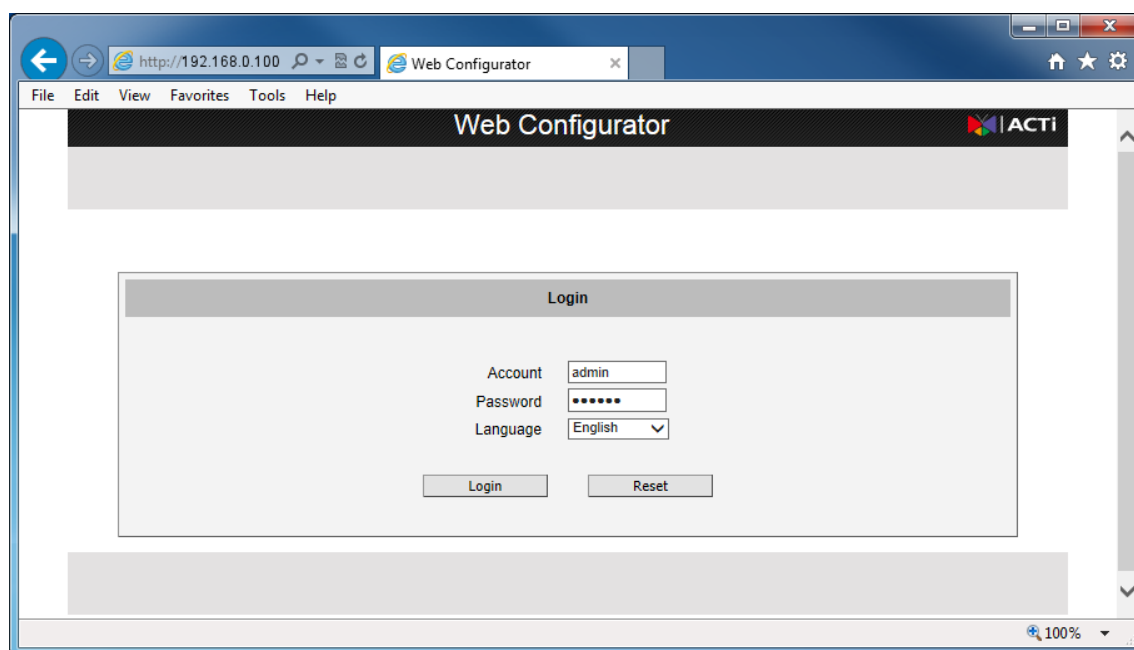

Before logging in, you need to know the factory default Account and Password of the encoder.

Account: **Admin**

Password: **123456**



Copyright © 2014, ACTi Corporation All Rights Reserved

7F, No. 1, Alley 20, Lane 407, Sec. 2, Ti-Ding Blvd., Neihu District, Taipei, Taiwan 114, R.O.C.

TEL : +886-2-2656-2588    FAX : +886-2-2656-2599

Email: [sales@acti.com](mailto:sales@acti.com)