



AL300ULX Series Power Supply/Charger

Installation Guide

Models Include:

- ***AL300ULX***
 - *Single Output*

- ***AL300ULPD4***
 - *Four (4) Fused Outputs*

- ***AL300ULPD8***
 - *Eight (8) Fused Outputs*

- ***AL300ULXPD16***
 - *Sixteen (16) Fused Outputs*

- ***AL300ULPD4CB***
 - *Four (4) PTC Outputs*

- ***AL300ULPD8CB***
 - *Eight (8) PTC Outputs*

- ***AL300ULXPD16CB***
 - *Sixteen (16) PTC Outputs*







For a red enclosure add an "R" suffix to the part # e.g. AL300ULPD8R

Overview:

The AL300ULX is a power supply that converts a 115VAC, 60Hz input to a 12VDC or 24VDC regulating output (*see specifications below*).

The AL300ULX is a base power supply unit for the UL Listed multi-output power supply/charger series: AL300ULPD4, AL300ULPD4CB, AL300ULPD8, AL300ULPD8CB, AL300ULXP16, AL300ULXP16CB (*Refer to AL300ULX Series Power Supply Configuration Reference Chart below*).

AL300ULX Series Power Supply Configuration Reference Chart:

Altronix Model Number	Accessory Power Distribution Module(s)	Number of Outputs	Fused Outputs	PTC Outputs	Total Output Rating (amp)	Output Rating (amp) per Output	Power Supply Input Fuse Rating	Power Supply Output Fuse Rating	Agency Listings	UL Listings and File Numbers
AL300ULX AL300ULXX AL300ULXR	—	1	—	—	2.5	2.5	5A/ 250V	15A/ 32V	   	UL File # S4707 UL 294 UL Listed for Access Control System Units. UL 603 UL Listed for Power Supplies for Use with Burglar-Alarms Systems. UL 1069 UL Listed Hospital Signaling and Nurse Call Equipment. UL 1481 UL Listed for Power Supplies for Fire Protective Signaling Systems “Signal Equipment” Evaluated to CSA Standard C22.2 No.205-M1983
AL300ULPD4	PD4UL	4	x	—	2.5	3.5	5A/ 250V	15A/ 32V	 	
AL300ULPD4CB	PD4ULCB		—	x		2.5				
AL300ULPD8	PD8UL	8	x	—	2.5	3.5	5A/ 250V	15A/ 32V		
AL300ULPD8CB	PD8ULCB		—	x		2.5				
AL300ULXP16	Two (2) PD8UL	16	x	—	2.5	3.5	5A/ 250V	15A/ 32V		
AL300ULXP16CB	Two (2) PD8ULCB		—	x		2.5				

Specifications:

Input:

- Input 115VAC, 60Hz, 3.5 amp.
- AC input and DC output LED indicators.

Output:

- Class 2 Rated power-limited output(s).
- 12VDC or 24VDC selectable output(s).
Burglar Alarm Applications (UL 603):
12VDC = 10VDC-13.2VDC.
24VDC = 20VDC-26.4VDC.
- 2.5 amp total supply current.
- Filtered and electronically regulated output(s).
- Short circuit and thermal overload protection.

Battery Backup:

- Built-in charger for sealed lead acid or gel type batteries.
- Automatic switch over to stand-by battery when AC fails.
- Maximum charge current 0.7 amp.
- Zero voltage drop when switched over to battery backup.

Supervision:

- AC fail supervision (form “C” contacts).
- Low battery and battery presence supervision (form “C” contacts).

Additional Features:

- Power supply, enclosure, cam lock and battery leads.
- All models are available in red enclosure (add an “R” suffix to the part # e.g. AL300ULPD8R).

Power Supply Output Specifications:

Output	Switch Position
12VDC	SW1 - ON
24VDC	SW1 - OFF

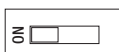

OFF - 24V
ON - 12V

Stand-by Specifications (total current shown):

Output	4 hr. of Stand-by and 5 Minutes of Alarm	24 hr. of Stand-by and 5 Minutes of Alarm	60 hr. of Stand-by and 5 Minutes of Alarm
12VDC / 40AH Battery	Stand-by = 2.5 amp Alarm = 2.5 amp	Stand-by = 1.0 amp Alarm = 2.5 amp	Stand-by = 300mA Alarm = 2.5 amp
24VDC / 12AH Battery	—	Stand-by = 200mA Alarm = 2.5 amp	—
24VDC / 40AH Battery	Stand-by = 2.5 amp Alarm = 2.5 amp	Stand-by = 1.0 amp Alarm = 2.5 amp	Stand-by = 300mA Alarm = 2.5 amp

Installation Instructions:

Wiring methods shall be in accordance with the National Electrical Code/NFPA 70/NFPA 72/ANSI, and with all local codes and authorities having jurisdiction. Product is intended for indoor use only.

1. Mount unit in the desired location. Mark and predrill holes in the wall to line up with the top two keyholes in the enclosure. Install two upper fasteners and screws in the wall with the screw heads protruding. Place the enclosure's upper keyholes over the two upper screws; level and secure. Mark the position of the lower two holes. Remove the enclosure. Drill the lower holes and install two fasteners. Place the enclosure's upper keyholes over the two upper screws. Install the two lower screws and make sure to tighten all screws (*Enclosure Dimensions, pgs. 7, 8*). Secure enclosure to earth ground.

Fig. 1 CAUTION: De-energize unit prior to servicing. For continued protection against risk of electric shock and fire hazard replace fuse with the same type and rating. Do not expose to rain or moisture.

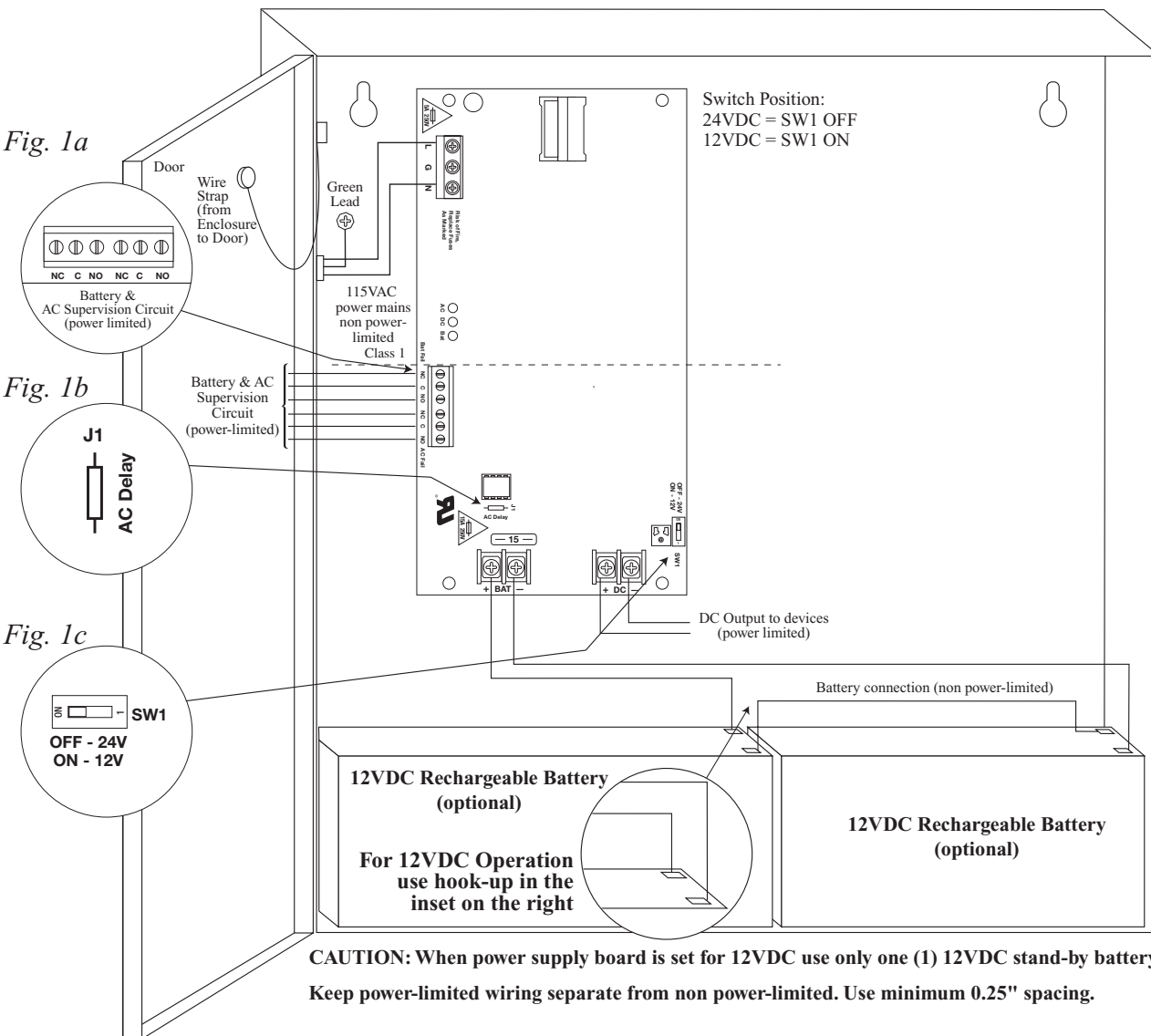

Installation Instructions (cont'd):

2. Set the unit to the desired DC output voltage by setting SW1 (Fig. 1c, pg. 3) to the appropriate position (Power Supply Output Specification Chart, pg. 2).
3. Secure cabinet to earth ground. Connect AC power (115VAC / 60 Hz) to the terminals marked [L, N] (Fig. 1, pg. 3). Use 14 AWG or larger for all power connections (Battery, DC output, AC input). Use 22 AWG to 18 AWG for power-limited circuits (AC fail/Low Battery reporting).

Keep power-limited wiring separate from non power-limited wiring (115VAC / 60Hz Input, Battery Wires). Minimum 0.25" spacing must be provided.

CAUTION: Do not touch exposed metal parts. Shut branch circuit power before installing or servicing equipment. There are no user serviceable parts inside. Refer installation and servicing to qualified service personnel.

For Fire Alarm applications the outputs are "Special Applications" only see list (refer to Appendix A, pg. 6).

For other devices contact Underwriters Laboratories to insure compatibility.

4. Measure output voltage before connecting device. This helps avoiding potential damage. When servicing the unit, AC mains should be removed.
5. Connect devices to be powered:
 - a. For AL300ULX Power Supply: connect devices to the terminals marked [+ DC -] (Fig. 1, pg. 3).
 - b. For other Power Distribution Models: connect devices to be powered to the terminal pairs 1 to 4 marked [1P & 1N through 4P & 4N] (Fig. 2a & 2b, pg. 5) or 1 to 8 marked [1P & 1N through 8P & 8N] (Fig. 3a & 3b, pg. 5), carefully observing correct polarity.
6. For Access Control applications batteries are optional. When batteries are not used, a loss of AC will result in the loss of output voltage. When the use of stand-by batteries is desired, they must be lead acid or gel type. Connect one (1) 12VDC battery to the terminals marked [+ BAT -] for 12VDC operation. Use two (2) 12VDC batteries wired in series for 24VDC operation.
7. Connect appropriate signaling notification devices to AC FAIL & BAT FAIL (Fig. 1a, pg. 3) supervisory relay outputs.

Note: When used in fire alarm, burglar alarm or access control applications, "AC Fail" relay should be utilized to visually indicate that AC power is on. To delay report for 6 hours cut "AC Delay" jumper (Fig. 1b, pg. 3).
8. Please ensure that the cover is secured with the provided key lock.

LED Diagnostics:

Power Supply Board

Red (DC)	Green (AC)	Power Supply Status
ON	ON	Normal operating condition.
ON	OFF	Loss of AC. Stand-by battery supplying power.
OFF	ON	No DC output.
OFF	OFF	Loss of AC. Discharged or no stand-by battery. No DC output.

Red (Bat)	Battery Status
ON	Normal operating condition.
OFF	Battery fail/low battery.

Power Distribution Module

Green	Power Distribution Module Status.
ON	Normal operating condition.
OFF	No Power Output.

Terminal Identification:

Power Supply Board

Terminal Legend	Function/Description
L, G, N	Connect 115VAC 60Hz. to these terminals: L to Hot, N to Neutral. Do not use the [G] terminal.
+ DC -	12VDC or 24VDC @ 2.5 amp continuous power-limited output.
AC Fail NC, C, NO	Indicates loss of AC power, e.g. connect to annunciator/alarm panel. Relay normally energized when AC power is present. Contact rating 1 amp @ 28VDC. AC Fail condition will report approximately within one (1) minute after loss of AC. To delay report for 6 hours cut jumper J1 on the Power Supply Board (AC trouble output delay option). If this mode is selected, the Power Supply Board must be reset by removing all power to it for 30 seconds.
Bat Fail NC, C, NO	Indicates low battery condition, e.g. connect to alarm panel. Relay normally energized when DC power is present. Contact rating 1 amp @ 28VDC. Low battery conditions will report approximately 21VDC (24VDC output setting) or approximately 10.5VDC (12VDC output setting). Battery presence detection will report approximately 1 minute after battery remains undetected (missing or removed).
+ BAT -	Stand-by battery connections. Maximum charge current 0.7 amp.

Power Distribution Module

Terminal Legend		Function/Description
PD4UL/PD4ULCB	PD8UL/PD8ULCB	
1P to 4P	1P to 8P	Positive DC power outputs.
1N to 4N	1N to 8N	Negative DC power outputs.

Power Distribution Module(s):

Fig. 2a

Replace fuses with the same type and rating 3.5A, 250V.

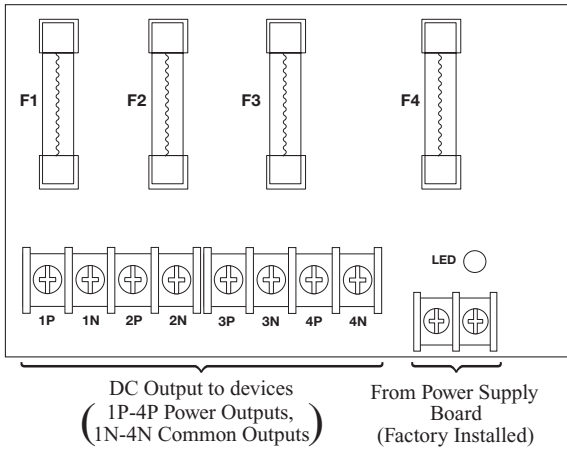

Fig. 2b

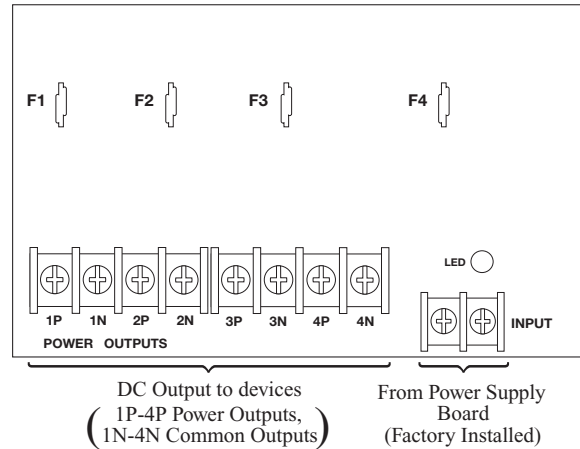

Fig. 3a

Replace fuses with the same type and rating 3.5A, 250V.

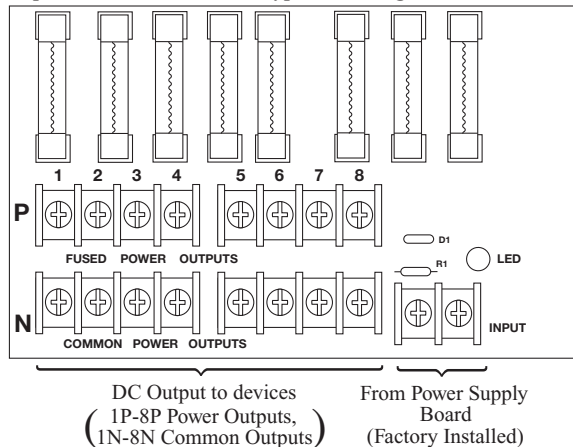
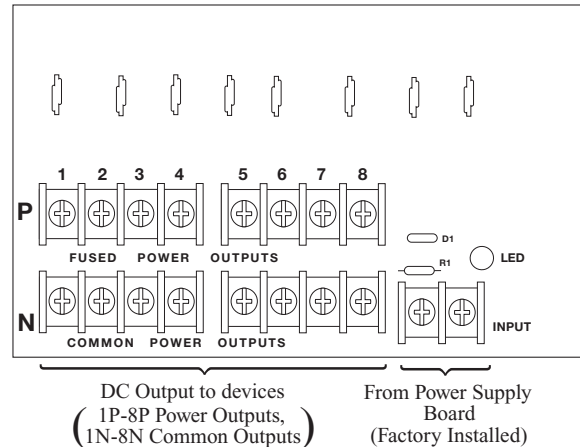

Fig. 3b



Appendix A - UL Listed Compatible Devices

A.1 Four (4) Wire Smoke Detectors

Table A-1 below lists four (4) wire smoke detectors compatible with AL300ULX output.

System Sensor Smoke Detector/Base	Detector Type	Max Stand-by Current (mA)	Alarm Current (mA)
B112LP	Base	0.12	36
B114LP	Base	*	*
B404B	Base	*	*
DH100ACDC	Photoelectric	0.15	0.70
DH100ACDCLP	Photoelectric	0.15	0.70
DH100ACDCLPW	Photoelectric	0.15	0.70
DH400ACDCI	Ionization Duct	25	95
DH400ACDCP	Photoelectric Duct	25	95
1112/24/D	Ionization	0.05	50
1424	Ionization	0.10	41
1451 (w/B402B Base)	Ionization	0.10	39
2112/24ATR	Photoelectric	0.50	60/70
2112/24AITR	Photoelectric	0.50	60/70
2112/24/D	Photoelectric	0.05	50
2112/24T/D	Photoelectric w/135° Thermal	0.05	50
2112/24TSRB	Photoelectric w/135° Thermal Supervisory Relay	15	45
2312/24TB	Photoelectric	0.12	50
2412 (12 volt)	Photoelectric	0.12	77
2424	Photoelectric	0.10	41
2451	Photoelectric	0.10	39
2451TH (with/B402B Base)	Photoelectric	0.10	39
2W-MOD	Loop Test/Maintenance Mod.	30	50
4W-B (12/24 volt)	Photoelectric I ³	0.05	23
4WT-B (12/24 volt)	Photoelectric I ³ w/Therm	0.05	23
4WTA-B (12/24 volt)	I ³ Photo w/Therm/Sounder	0.05	35
4WTR-B (12/24 volt)	I ³ Photo w/Therm/Relay	0.05	35
4WITAR-B (12/24 volt)	I ³ Photo w/Isolated Therm/Sounder/Relay	0.05	50
2W-MOD2	I ³ Loop Test/Maintenance Mod.	0.05	*
RRS-MOD	I ³ Reversing Relay/Sync Module	0.05	*
6424	Projected Beam	10	28.4
Beam 1224(S)	Projected Beam	17	38.5

* Contact manufacturer for current draws.

A.2 Relays

Table A-2 below lists relays compatible with AL300ULX output.

Manufacturer	Model	Current (mA)
System Sensor	PR-1	15
	PR-2	30
	PR-3	30
	EOLR-1	30
	R-10T	23
	R-14T	23

Manufacturer	Model	Current (mA)
System Sensor	R-20T	40
	R-24T	40
	R-10E	23
	R-14E	23
	R-20E	40
	R-24E	40

Enclosure Dimensions (BC400):

AL300ULXX, AL300ULXXR, AL300ULXPD4, AL300ULXPD4CB,

AL300ULXPD8, AL300ULXPD8CB, AL300ULXPD16, AL300ULXPD16CB

15.5" x 12" x 4.5" (393.7mm x 304.8mm x 114.3mm)

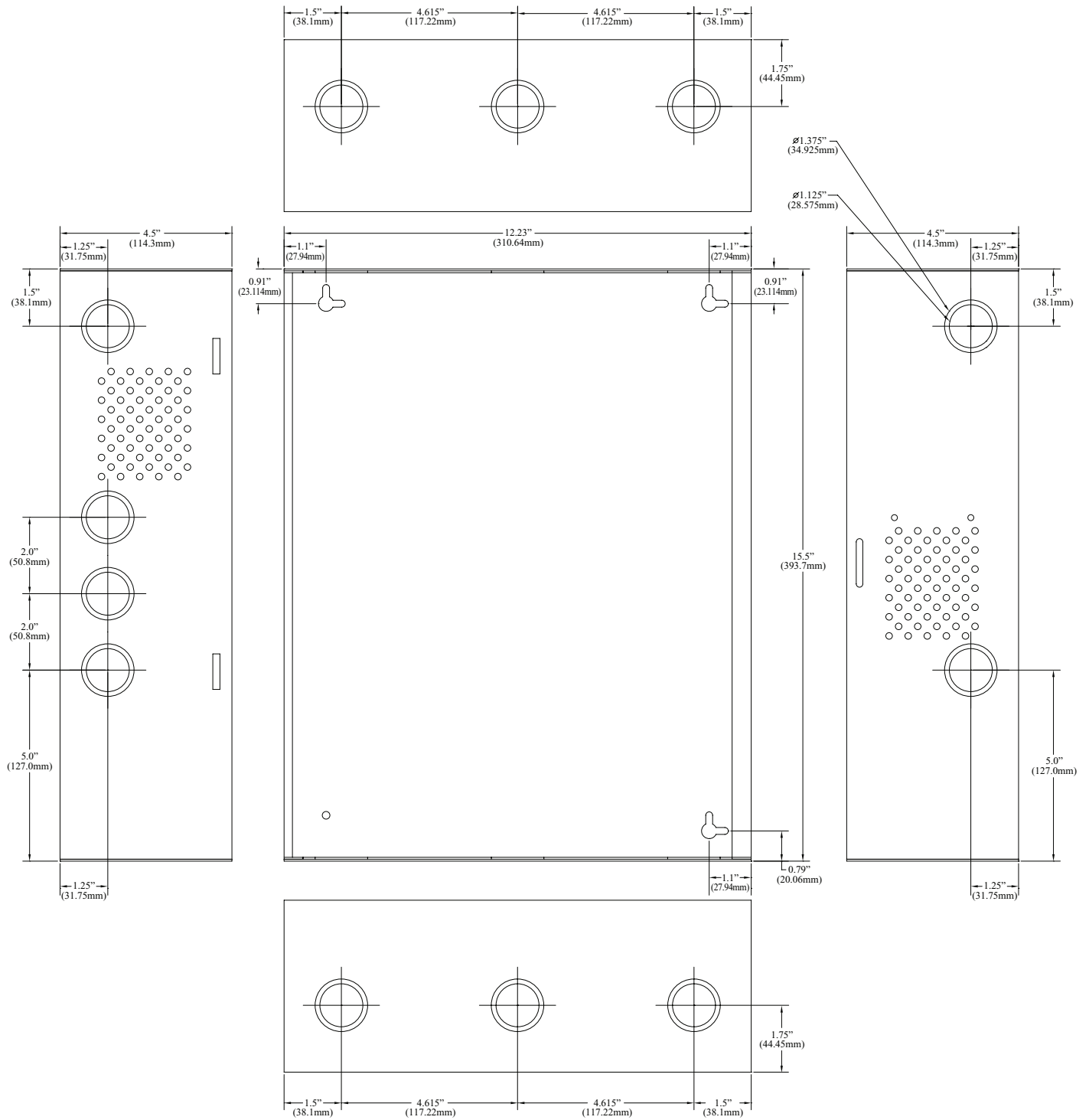

Altronix is not responsible for any typographical errors.

140 58th Street, Brooklyn, New York 11220 USA, 718-567-8181, fax: 718-567-9056
 web site: www.altronix.com, e-mail: info@altronix.com, Lifetime Warranty, Made in U.S.A.
 IIAL300ULX series

J01N