

TROUBLESHOOTING

Problem:	Possible cause:	Solutions:
<ul style="list-style-type: none"> Door does not lock Status LED is not illuminated 	No power	<ul style="list-style-type: none"> Check to make sure the wires are securely tightened to the terminal block. Check that the power supply is connected and operating. Make sure the lock switch is wired correctly.
Door locks, but can be easily forced open	Poor contact between electromagnet and armature plate	<ul style="list-style-type: none"> Make sure the electromagnet and armature plate are properly aligned. Make sure the contact surfaces of the electromagnet and armature plate are clean and free from rust.
	Incorrect voltage setting	<ul style="list-style-type: none"> Check the power leads with a meter, and make sure 12VDC or 24VDC is present.
Delay in door releasing	<ul style="list-style-type: none"> A secondary diode was installed across the electromagnet 	<ul style="list-style-type: none"> The electromagnet is fitted with a metal oxide varistor to prevent interference, so do not install a secondary diode.
No relay output	<ul style="list-style-type: none"> No power Misalignment 	<ul style="list-style-type: none"> Check that the power is connected and operating. Make sure the lock is aligned properly. Make sure the NO/NC/COM are wired properly.
Delay in door relocking	<ul style="list-style-type: none"> Check timer 	<ul style="list-style-type: none"> Make sure timer is adjusted to desired delay time.

REGULAR MAINTENANCE

- Clean the contact surfaces of the electromagnet or armature plate with a soft cloth and non-abrasive, non-corrosive cleaner.
- Apply a light coat of a silicon lubricant to prevent rust. Wipe away the excess.
- Check that the armature plate is securely attached to the door, yet can pivot slightly around the armature screw.
- Check that the electromagnet is securely attached to the door frame.

WARRANTY: SECO-LARM Electromagnetic Locks are warranted against defects in material and workmanship while used in normal service for a period of one (1) year from the date of sale to the original customer. Our obligation is limited to the repair or replacement of any defective part if the unit is returned, transportation pre-paid, to SECO-LARM.

NOTICE

The information and specifications printed in this manual are current at the time of publication. However, the SECO-LARM policy is one of continual development and improvement. For this reason, SECO-LARM reserves the right to change specifications without notice. SECO-LARM is also not responsible for misprints or typographical errors.

Copyright © 2010 SECO-LARM U.S.A., Inc. All rights reserved. This material may not be reproduced or copied, in whole or in part, without the written permission of SECO-LARM.

SECO-LARM U.S.A., Inc.

16842 Millikan Avenue, Irvine, CA 92606

Tel: 800-662-0800 / 949-261-2999 Fax: 949-261-7326

Website: www.seco-larm.com

E-mail: sales@seco-larm.com

TP TGW1
E941SA1K2PD.pmd

Installation Manual

SECO-LARM

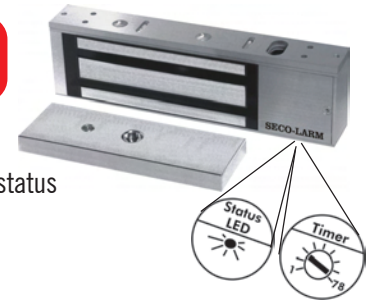

E-941SA-1K2PD

1200 Pound Holding Force Electromagnetic Lock with status sensor, LED status display and adjustable time delay.

Also available:

Single-Door Locks

E-941SA-600 - 600-lb holding force, UL listed

E-941SA-600PQ - 600-lb holding force, bond sensor, LED, UL listed

E-941SA-1200 - 1,200-lb holding force, UL listed

E-941SA-1K2PQ - 1,200-lb holding force, bond sensor, LED, UL listed

Double-Door Locks

E-941DA-600Q - 600-lb holding force, UL listed

E-941DA-600PQ - 600-lb holding force, bond sensor, LED, UL listed

E-941DA-1K2Q - 1,200-lb holding force, UL listed

E-941DA-1K2P - 1,200-lb holding force, bond sensor, LED, UL listed

HOW IT WORKS

When power is applied to the magnetic lock, it turns on the unit's powerful built-in electromagnet. This electromagnet is attracted to the steel armature plate which is mounted on a door, holding the door fast against unauthorized entry. When power to the magnetic lock is turned off, the electromagnet releases the armature plate, allowing the door to open. In addition, the E-941SA-1K2PD has built-in LEDs to show electromagnet status, plus a status sensor to monitor whether the door is securely closed, and a built-in adjustable-delay locking timer.

SPECIFICATIONS

E-941SA-1K2PD



Power	12/24 VDC
Magnet Size	10½ x 1⅝ x 2⅝ in. (268 x 42 x 67 mm)
Armature Size	7¼ x ⅝ x 2⅝ in. (185 x 16 x 61 mm)
Holding Force	1200-lb (545kg)
Status Sensor	Relay, 3A @ 12VDC
Status LED (2-Color)	Locked - Green, Unlocked - Red
Timer Delay	1 ~ 78 seconds
Current Drain	500mA @ 12VDC, 250mA @ 24VDC
Voltage Tolerance	± 10%
Housing	Aluminum
Temperature	14° ~ 131°F (-10° ~ 55°C)
Weight	11-lb (5.0 kg)

MOUNTING THE E-941SA-1K2PD

A. Drill holes for the mounting plate and armature plate (see fig. 1 and 2) by doing the following:

1. Fold the mounting template along the dotted line.
2. Close the door. Find a mounting location on the door frame near the upper free-moving corner of the door, as close to the corner of the door frame as possible.
3. Place the template against the door and frame.
4. Drill two holes in the door frame and three holes in the door as indicated on the template.

NOTE — A filler plate or an L-bracket or Z-bracket (optional) may be required for the electromagnet, depending on the door style. See fig. 1.

B. Mount the armature plate to the door using at least two steel and one rubber washer (fig. 2):

NOTE — Actual installation varies according to door style.

1. Put one rubber washer between two steel washers, and place them over the armature screw between the armature plate and the door. This will allow the armature plate to pivot slightly around the armature screw in order to compensate for door misalignment.
2. Tighten the sexnut bolt enough so the armature plate can withstand the force of someone attempting to break down the door while the electromagnet is engaged.
3. Do not tighten the armature plate

against the door. The plate must be able to pivot around the armature screw.

4. Make sure the anti-spin guides are in the two guidepin holes.
- C. Screw the mounting plate to the door frame or optional bracket:

1. Screw the two short self-tapping screws in the slotted holes of the mounting plate and adjust the position of the mounting plate so that it and the armature plate form a 90-degree angle.
2. Once the position is correct, use the long self-tapping screws to permanently mount the bracket.
3. Remove the two short screws.

D. Drill the cable access hole.

E. Mount the electromagnet to the door frame (fig. 1) — Use the Allen wrench to screw the socket-head mounting screws through the bottom of the electromagnet into the mounting bracket.

- F. Connect the power leads (fig. 3):
1. Open the electromagnet.
 2. Run two power leads from the power supply through the cable access hole into the electromagnet.
 3. Connect the power leads to the terminal block.
 4. Close the electromagnet.

G. Test the unit.

H. Insert the tamper caps into the mounting screw access holes. This should be the last step, as once the tamper caps are in place, they will be difficult to remove.

FIG. 1

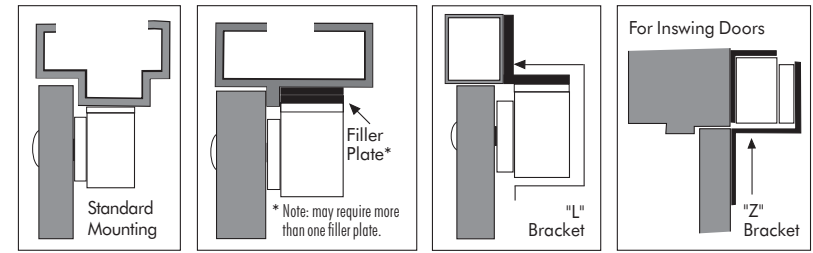

FIG. 2

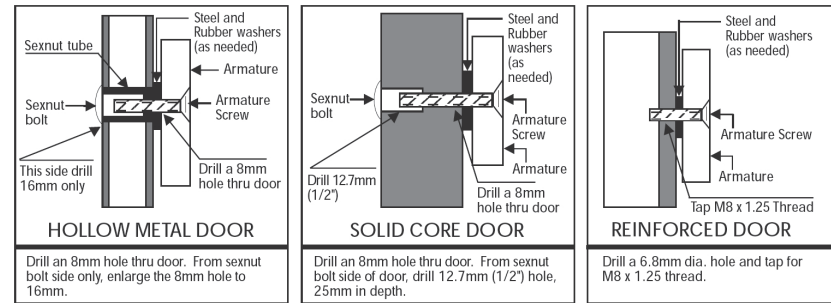
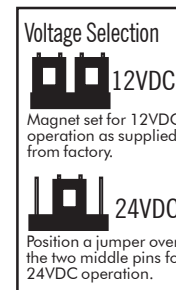
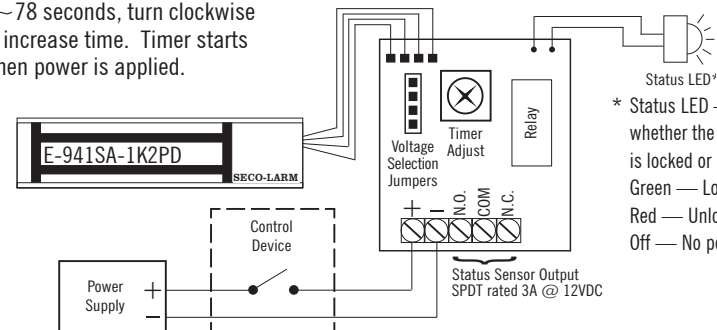

FIG. 3: Status Sensor Output - Connect to an alarm panel or other monitoring device.



Status Sensor Output — Monitors whether the protected door is open or closed.
 N.C. — Door opened, red LED on.
 N.O. — Door closed, green LED on.
 Relay — 3A @ 12VDC.

Adjustable Timer Delay — For 1~78 seconds, turn clockwise to increase time. Timer starts when power is applied.



Status LED*
 * Status LED — Indicates whether the magnetic lock is locked or unlocked.
 Green — Locked
 Red — Unlocked
 Off — No power