

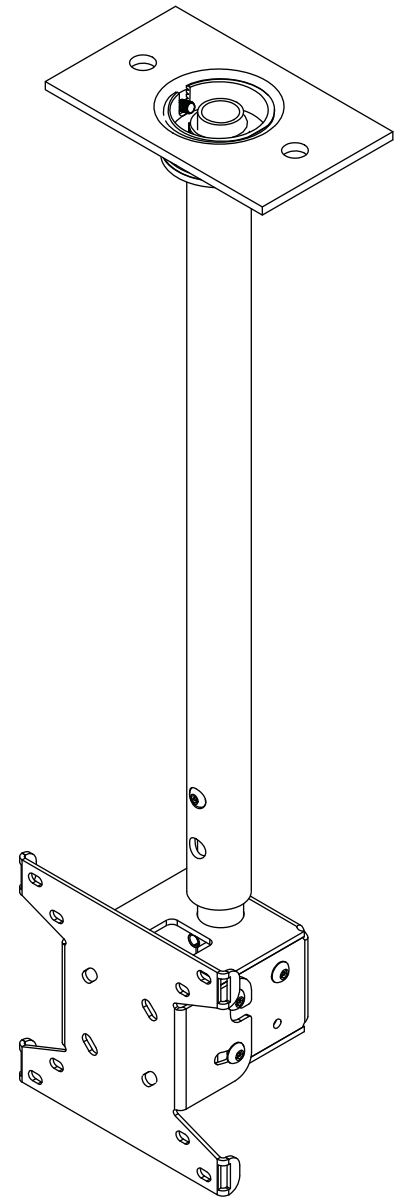

## Installation and Assembly: Ceiling mount for LCD screens up to 29"

**Models:** LCC-18, LCC-18-S, LCC-36, LCC-36-S, LCC-36-W

Patent Pending



### Features:

- Comes in two adjustable height ranges (in 1" increments): 18"-30" and 36"-48".
- -5° to +20° adjustable tilt.
- Screen can be mounted in standard position or face-down.
- Portrait or landscape orientation.
- Ceiling plate included.
- Hardware included for wood or concrete installations.
- Theft resistant security fasteners included.
- VESA® 75/100 mm compliant (Non-VESA adapter offered separately).
- Comes in black or silver. LCC 36-W offered in white.
- 360° swivel action.



**Max UL Load Capacity: 40 lb (18.1 kg)**

**Note:** Read entire instruction sheet before you start installation and assembly.

## **WARNING**

- Do not begin to install your Peerless product until you have read and understood the instructions and warnings contained in this Installation Sheet. If you have any questions regarding any of the instructions or warnings, for US customers please call Peerless customer care at 1-800-865-2112, for all international customers, please contact your local distributor.
- This product should only be installed by a qualified professional.
- Make sure that the ceiling will safely support the combined load of the equipment and all attached hardware and components.
- Never exceed the Maximum UL Load Capacity. See page 1.
- If mounting to wood ceiling joists, make sure that mounting screws are anchored into the center of the joists. Use of an "edge to edge" stud finder is highly recommended.
- Always use an assistant or mechanical lifting equipment to safely lift and position equipment.
- Tighten screws firmly, but do not overtighten. Overtightening can damage the items, greatly reducing their holding power.

## **Accessories**

- Lightweight Adjustable Suspended Ceiling Kit (CMJ 500)
- Lightweight Suspended Ceiling Kit (CMJ 455)
- Accessory Pack for CMJ 455 (ACC455)\*
- Lightweight Cathedral Ceiling Plate (ACC912)\*
- Unistrut or Structural Ceiling Plates (CMJ 300, CMJ 310)\*
- Anti-Vibration Ceiling Plates (ACC845)\*
- I-Beam Clamps (ACC558, ACC559)
- Truss Ceiling Adapter (ACC557)\*
- Unistrut Adapter (ACC550)
- Escutcheon Ring (ACC640)\*
- Round Ceiling Plate (ACC570)
- Cord Wrap (ACC852(W)(S))\*
- Fixed Length 1 1/2" Extension Columns (EXT models)
- Adjustable Length 1 1/2" Extension Columns (ADJ models)
- Extension Column Stabilizer Kit (ACC050)\*
- Extension Column Connector (ACC109)
- 1/2" Threaded Rod (ACC820)\*
- Threaded Rod Adapter (ACC810)\*
- Non-VESA Adapter Plates (LC models)\*

**\*not evaluated by UL**

## **Tools Needed for Assembly**

- stud finder ("edge to edge" stud finder is recommended)
- phillips screwdriver
- drill with 1/4", 3/8", and 5/32" drill bits

## **Table of Contents**

Parts List.....	3
Installation to Wood Joist Finished Ceilings, Exposed Wood Joists, or Wood Beam Ceilings.....	4
Installation to Concrete Ceilings.....	5
Installing Reducer.....	6
Flush Mount Installation.....	7
Installation to Threaded Rod.....	7
Installation to Extension Column.....	8
Installation to Lightweight Suspended Ceiling Plate.....	9
Attaching Tilt Bracket to LCD Screen.....	10
Installation of screen in the Vertical Position.....	11
Installation of screen in the Horizontal Position.....	12

# Parts List

Description	Qty.	LCC-18 Part #	LCC-18S Part #	LCC-36 Part #	LCC-36S Part #
<b>A</b> tube assembly	1	055-1520	055-4520	055-1521	055-4521
<b>B</b> ceiling plate	1	580-1042	580-4042	580-1042	580-4042
<b>C</b> tilt bracket	1	055-1551	055-4551	055-1551	055-4551
<b>D</b> reducer	1	580-1009	580-4009	580-1009	580-4009
<b>E</b> #14 x 2.5" wood screw	2	5S1-015-C03	5S1-015-C04	5S1-015-C03	5S1-015-C04
<b>F</b> M5 x 12 mm socket pin screw	4	520-1064	520-2064	520-1064	520-2064
<b>G</b> 4 mm security allen wrench	1	560-9646	560-9646	560-9646	560-9646
<b>H</b> concrete anchor	2	590-0097	590-0097	590-0097	590-0097
<b>I</b> 10-32 x 3/8" socket set screw	1	520-1127	500-2018	520-1127	500-2018
<b>J</b> hex wrench	1	560-1034	560-1034	560-1034	560-1034
<b>K</b> M4 x 10 mm socket pin screw	4	520-1060	520-2060	520-1060	520-2060
<b>L</b> M4 x 12 mm serrated washer head socket pin screw	4	510-1079	510-2079	510-1079	510-2079
<b>M</b> M4 x 20 mm socket pin screw	4	520-1061	520-2163	520-1061	520-2163
<b>N</b> #10-32 x 3/16" slotted set screw	1	520-1187	520-2187	520-1187	520-2187
<b>O</b> retaining spacer	4	590-5005	590-5003	590-5005	590-5003
<b>P</b> M5 x 10 mm socket pin F-type screw	1	520-1164	520-2031	520-1164	520-2031
<b>Q</b> cable tie	3	590-1168	590-1168	590-1168	590-1168

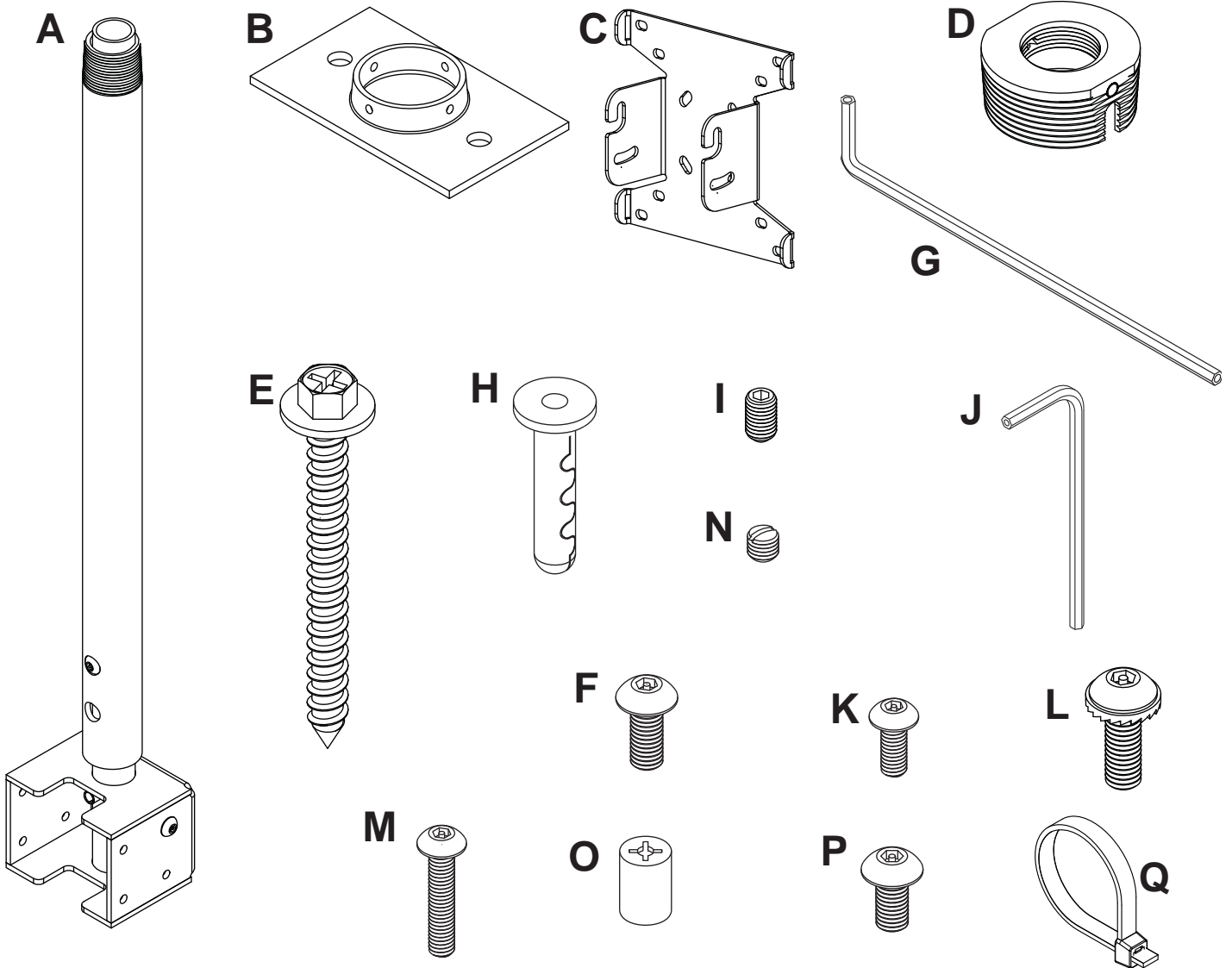

# Installation to Wood Joist Finished Ceilings, Exposed Wood Joists, or Wood Beam Ceilings

- 1 Drill two 5/32" (4 mm) dia. holes to a minimum depth of 2.5" (64 mm). Attach ceiling plate (B) with two #14 x 2.5" (6 mm x 65 mm) wood screws (E) as shown using 3/8" (10 mm) socket wrench. Tighten wood screws (E) so ceiling plate (B) is firmly attached.

## **⚠ WARNING**

- Tighten wood screws so that ceiling plate is firmly attached, but do not overtighten. Overtightening can damage the screws, greatly reducing their holding power.
- Never tighten in excess of 80 in • lb (9 N.M.).
- Make sure that mounting screws are anchored into the center of the joist. The use of an "edge to edge" stud finder is highly recommended.

Skip to step 2 on page 6.

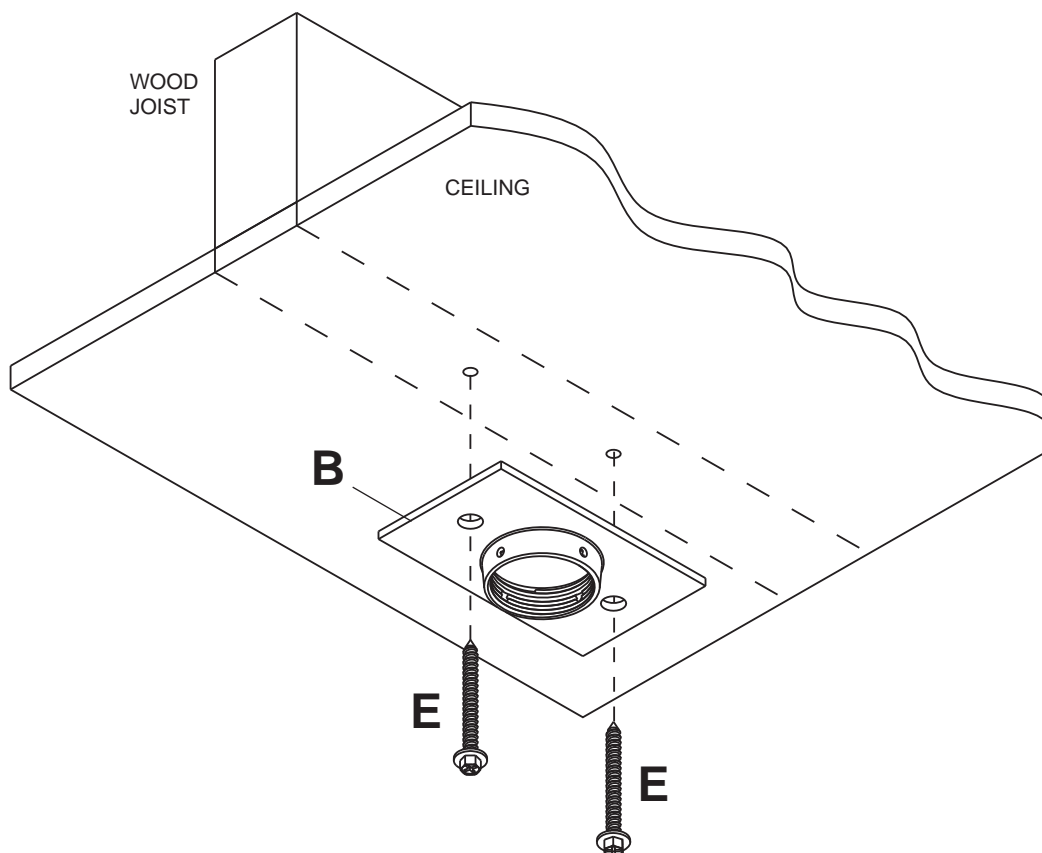

# Installation to Concrete Ceilings

- 1 Drill two 1/4" (6 mm) dia. holes to a minimum depth of 2.5" (64 mm). Attach ceiling plate (B) using two concrete anchors (H) and #14 x 2.5" wood screws (E) as shown in **Illustration A** and 1, 2, and 3 (below). Tighten all fasteners.

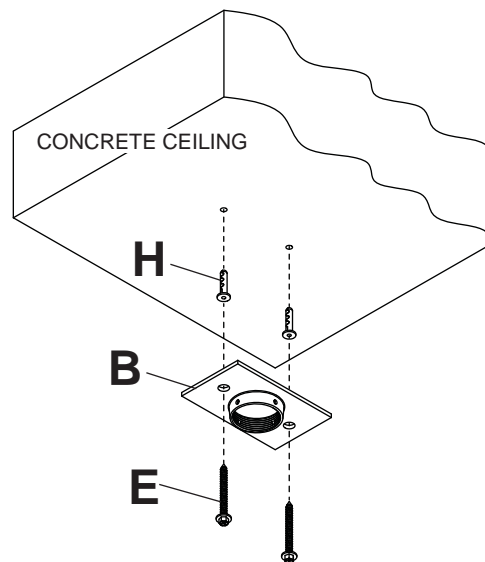

Illustration A

## ⚠ WARNING

- Tighten wood screws firmly, but do not overtighten. Overtightening can damage the bolt, greatly reducing its holding power.
- Never tighten in excess of 80 in • lb (9 N.M.).

## ⚠ WARNING

- Concrete anchors are **not** intended for attachment to concrete wall covered with a layer of plaster, drywall, or other finishing material. If mounting to concrete wall covered with plaster/drywall is unavoidable, plaster/drywall (up to 5/8" thick) must be counterbored as shown below. If plaster/drywall is thicker than 5/8", custom fasteners must be supplied by installer (not evaluated by UL).

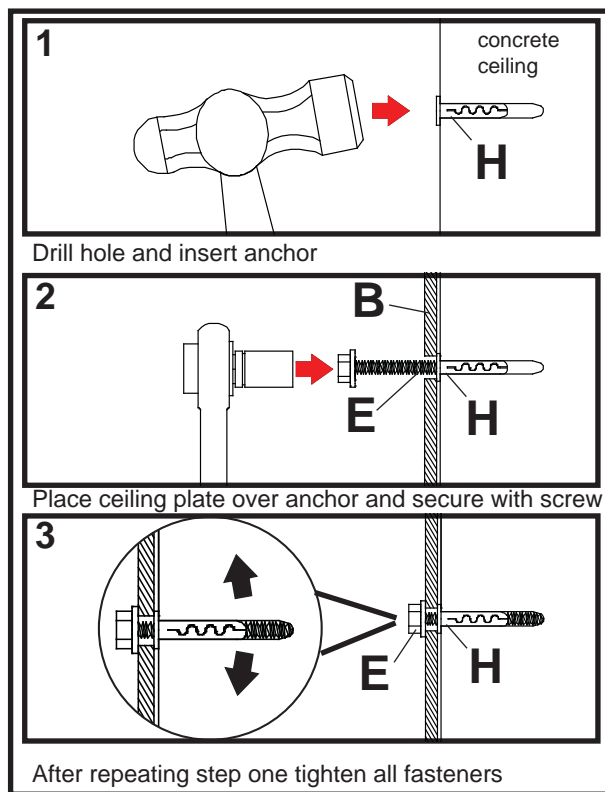
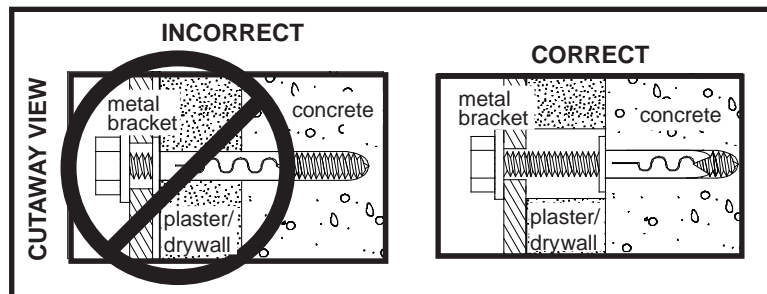

# Installing Reducer

2

Thread reducer (D) onto tube assembly (A) until tight. Insert set screw (I) into reducer as shown in figure 2.1. Tighten screw using hex wrench (J). **Note:** Set screw (I) is used to jam against the threads of tube assembly to prevent any excess movement.

To adjust height of tube assembly (A), remove socket pin screw and two lock washers using 4 mm security allen wrench (G) and adjust to desired height as shown in figure 2.2.

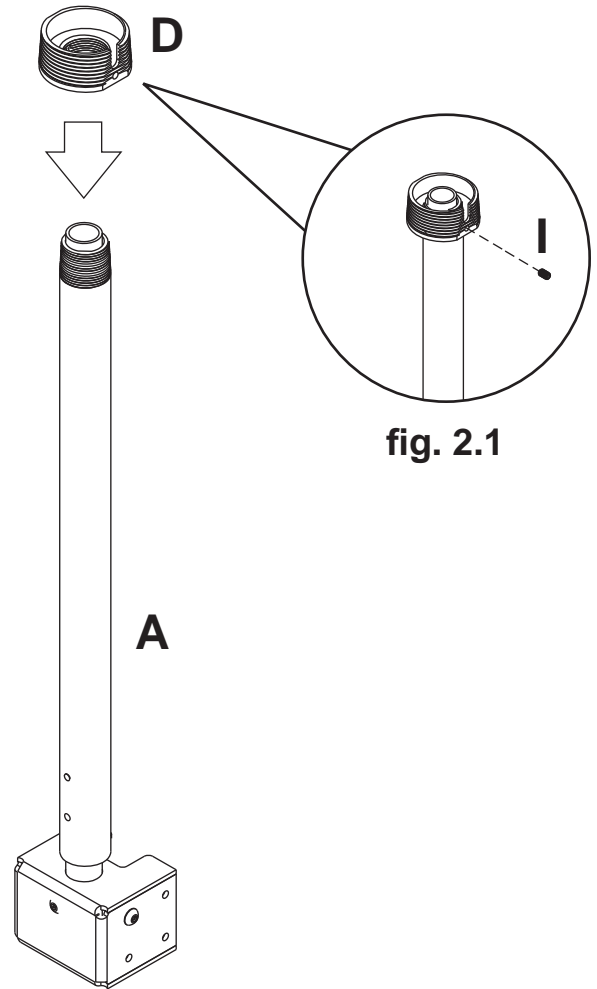

fig. 2.1

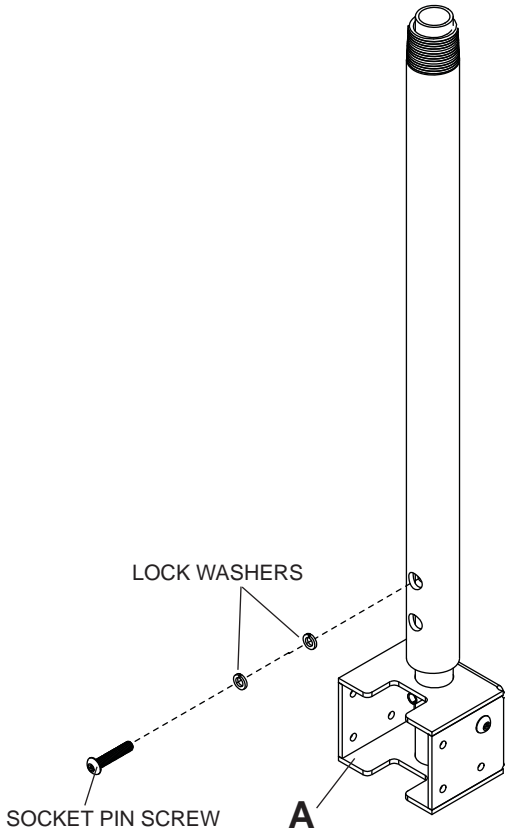
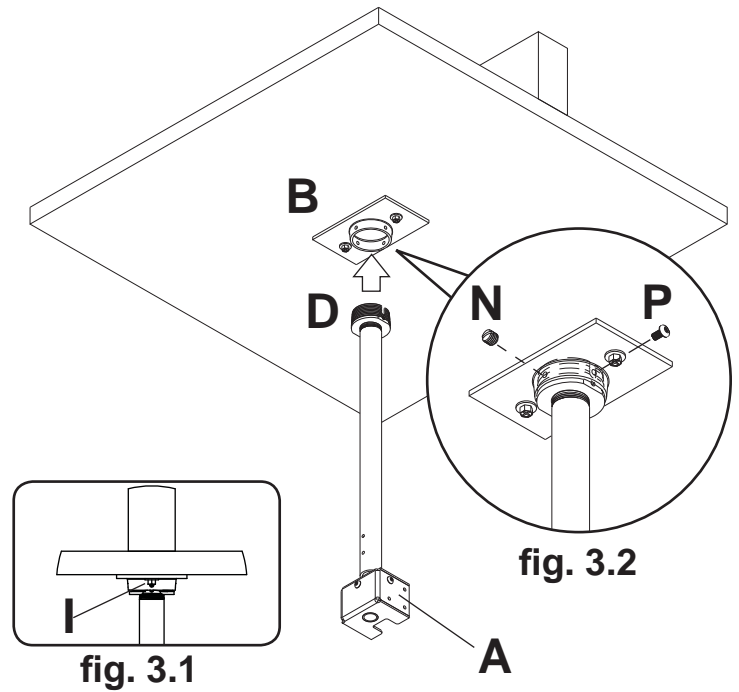

fig. 2.2

# Flush Mount Installation

**3** Screw reducer (**D**) into ceiling plate (**B**) until notch in reducer is aligned with one of the four holes in ceiling plate and set screw (**I**) is at least partially covered by ceiling plate as shown in figure 3.1. Secure reducer with one M5 x 10 mm F-type socket pin screw (**P**) using security allen wrench (**G**) as shown in figure 3.2. **Note:** Slotted set screw (**N**) is used to jam against the threads of the reducer to prevent any excess movement of the tube assembly (**A**). Do not overtighten screw; overtightening screw will damage threads making it difficult to separate the products.

Skip to step 4 on page 10.



# Installation to Threaded Rod

Accessory ACC810 (not evaluated by UL), threaded rod adapter, is required.

**3** Screw threaded rod adapter (**ACC810**) into extension column connector (**ACC109**). Align slot in threaded rod adapter with one of the top holes in extension column connector. Insert and tighten one #10-32 x 3/8" socket pin screw provided with extension column connector through extension column connector into slot on threaded rod adapter using 4 mm security allen wrench (**G**). See figure 3.3.

Align slot in reducer (**D**) to one of the bottom holes in extension column connector. Insert and tighten one #10-32 x 3/8" socket pin screw provided with extension column connector through extension column connector into slot in reducer. See figure 3.4.

**Note:** Slotted set screws provided with extension column connector are used to jam against the threads of each connecting joint to prevent any excess movement. Do not overtighten screws; overtightening screws will damage threads making it difficult to separate the products.

Skip to step 4 on page 10.

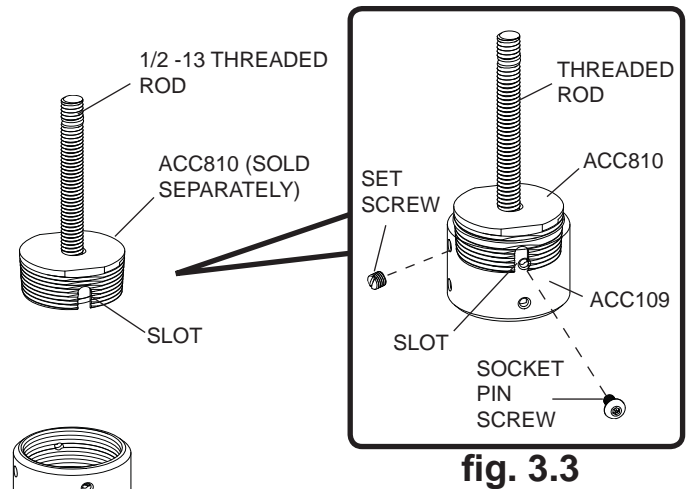

fig. 3.3

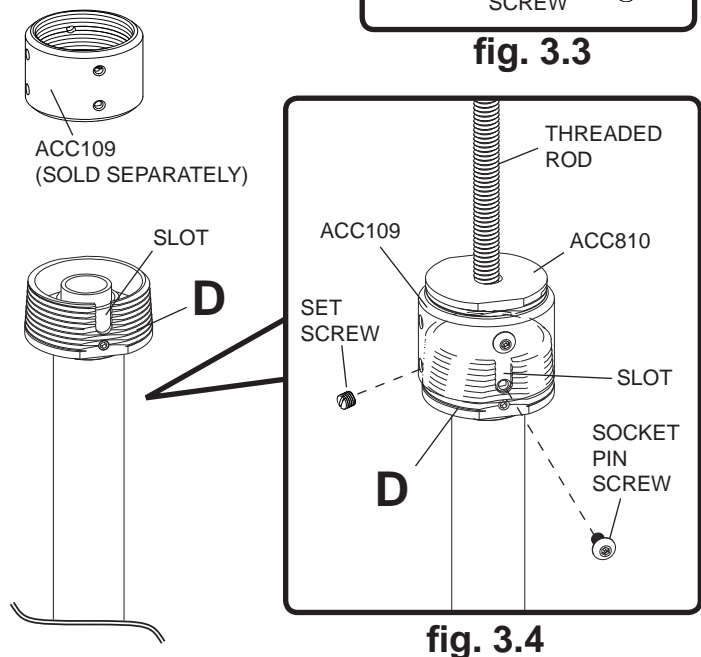

fig. 3.4

# Installation to Extension Column

**3** Screw extension column (**EXT or ADJ Series**) to ceiling plate (**B**). Align the notch with one of the four holes in the ceiling plate and secure extension column with a M5 x 10 mm socket pin screw (**P**) using security allen wrench (**G**). See figure 3.5.

**Note:** Slotted set screw (**N**) is used to jam against the threads of the reducer to prevent any excess movement of the extension column. Do not overtighten screw; overtightening screw will damage threads making it difficult to separate the products.

Screw extension column connector (**ACC109**) to extension column. Align slot in extension column with one of the top holes in extension column connector. Insert and tighten one #10-32 x 3/8" socket pin screw provided with projector through extension column connector into slot on extension column using security allen wrench (**G**). See figure 3.6.

Screw reducer (**D**) to extension column connector. Align reducer to one of the bottom holes in extension column connector. Insert and tighten one #10-32 x 3/8" socket pin screw provided with connector through extension column connector into slot in reducer using security allen wrench (**G**). See figure 3.7.

**Note:** Slotted set screws provided with extension column connector are used to jam against the threads of each connecting joint to prevent any excess movement. Do not overtighten screws; overtightening screws will damage threads making it difficult to separate the products.

Skip to step 4 on page 10.

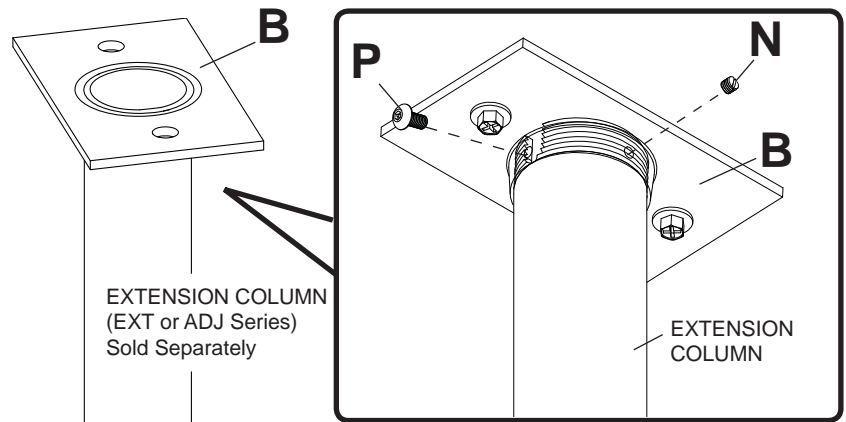

fig. 3.5

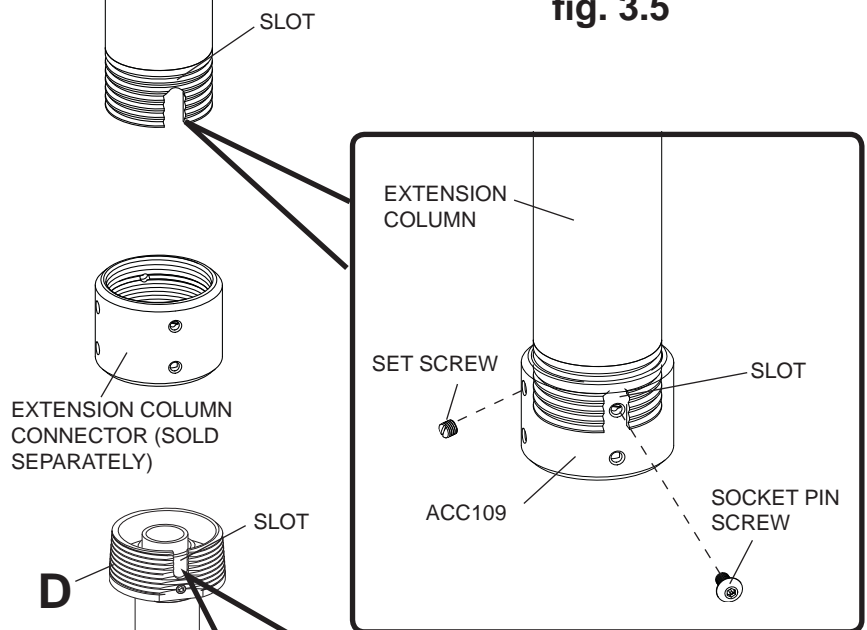

fig. 3.6

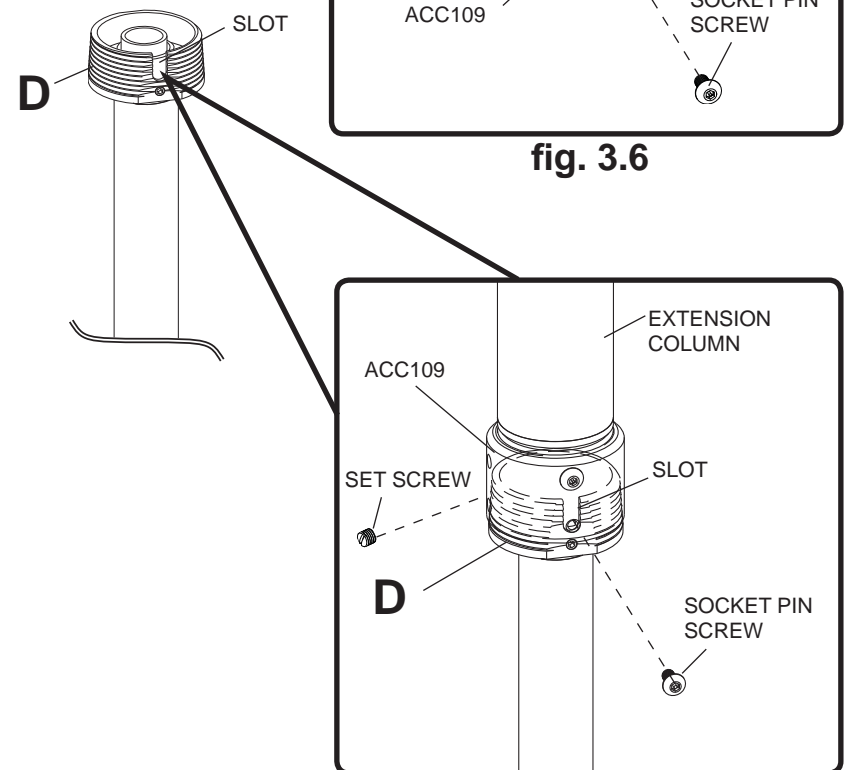
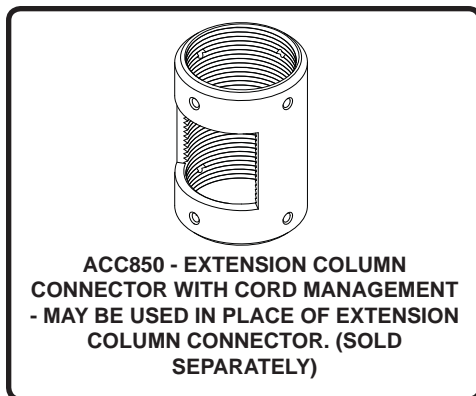

fig. 3.7





# Installation to Lightweight Suspended Ceiling Plate

**3** Refer to instruction sheet for lightweight suspended ceiling plate (**CMJ 455**) for attachment of ceiling plate to ceiling.

Screw extension column (**EXT or ADJ Series**) to retaining collar in ceiling tray. Align the notch with one of the four holes in retaining collar and secure extension column with one M5 x 10 mm socket pin screw (**P**) using security allen wrench (**G**). See figure 3.8.

**Note:** Slotted set screw (**N**) is used to jam against the threads of the reducer to prevent any excess movement of the extension column. Do not overtighten screw; overtightening screw will damage threads making it difficult to separate the products.

Screw extension column connector to extension column. Align slot in extension column with one of the top holes in extension column connector. Insert and tighten one 10-32 x 3/8 socket pin screw provided with connector through extension column connector into slot on extension column using security allen wrench. See figure 3.9.

Screw reducer (**D**) to extension column connector. Align slot in reducer to one of the bottom holes in extension column connector. Insert and tighten one 10-32 x 3/8 socket pin screw provided with connector through extension column connector into slot in reducer using security allen wrench. See figure 3.10.

**Note:** Slotted set screws provided with extension column connector are used to jam against the threads of each connecting joint to prevent any excess movement. Do not overtighten screws; overtightening screws will damage threads making it difficult to separate the products.

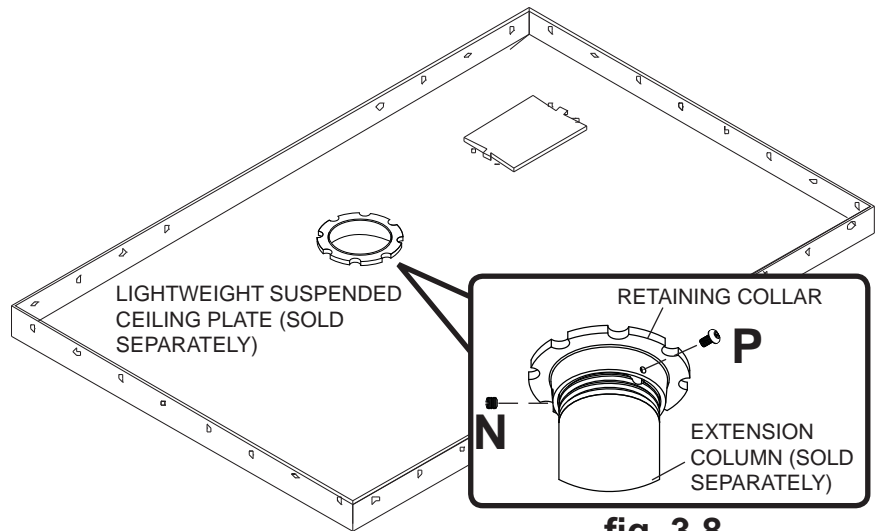

**fig. 3.8**

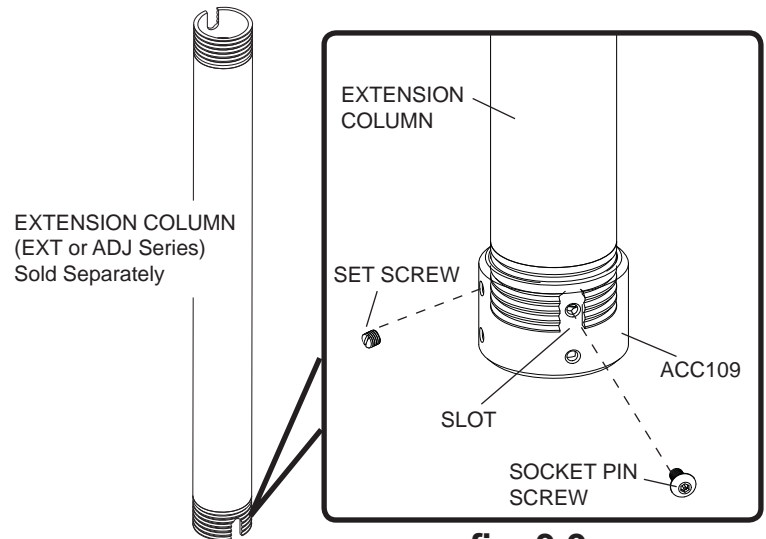

**fig. 3.9**

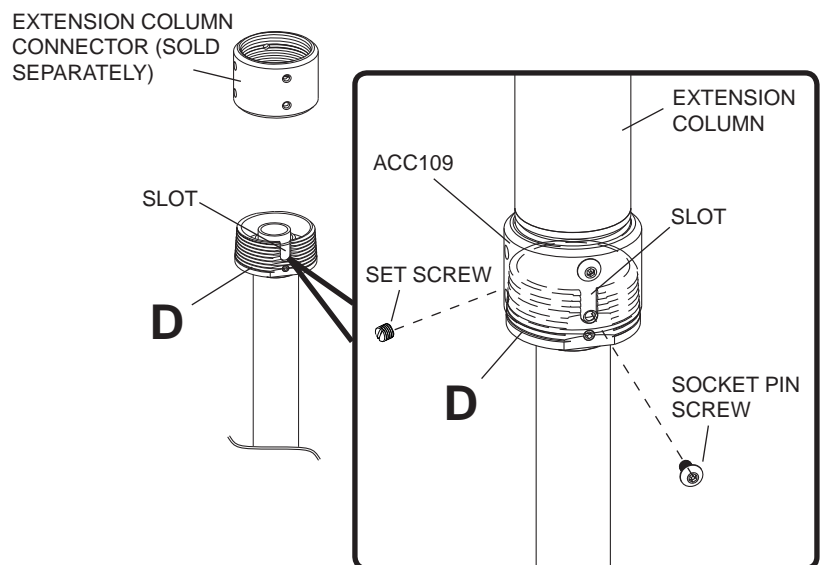

**fig. 3.10**

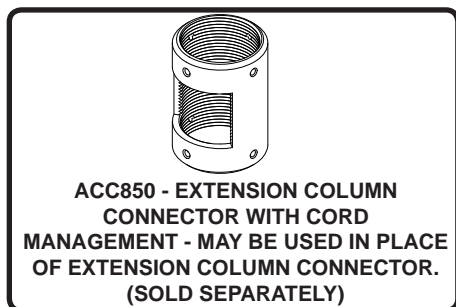

# Attaching Tilt Bracket to LCD Screen

**4** **Note:** This product is designed to accommodate screens with VESA® compliant hole patterns. For safe mounting, please make sure that mounting screws turn at least three complete turns in the screen inserts.

## FOR VESA 75 MOUNTING PATTERN:

1) Choose hole pattern indicated below. 2) Attach tilt bracket (**C**) to back of screen using four M4 x 10 mm screws (**K**) as indicated below. 3) If hole pattern is in a pocket, attach tilt bracket to back of screen using four M4 x 20 mm screws (**M**) and four retaining spacers (**O**) as indicated below. Tighten all security screws with security allen wrench (**G**).

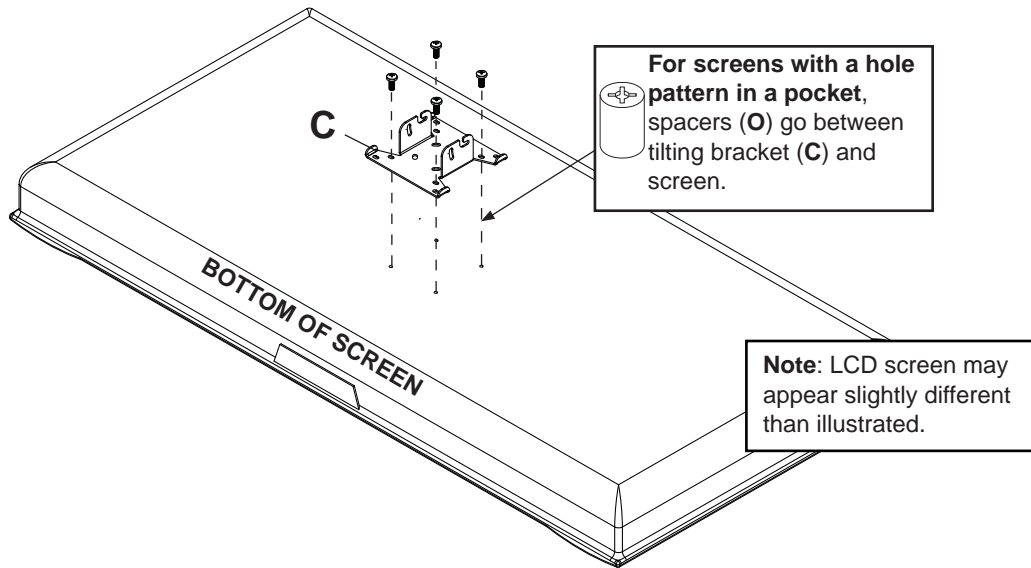

## FOR VESA 100 MOUNTING PATTERN:

1) Choose hole pattern indicated below. 2) Attach tilt bracket (**C**) to back of screen using four M4 x 10 mm screws (**K**) as indicated below. Tighten all security screws with security allen wrench (**G**).

**Note:** If installing LCD screen model Sharp® LC-13E1U, LC-15E1U, LC-20E1U, or if you don't get three complete turns in the screen inserts, use four M4 x 12 mm screws (**L**) instead of four M4 x 10 mm screws (**K**).

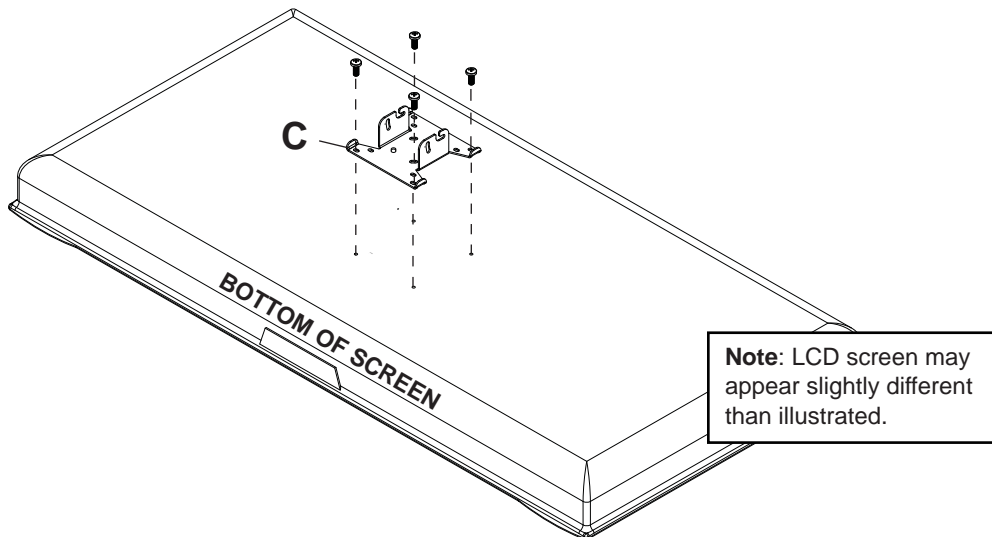

# Installation of Screen in the Vertical Position

- 5 Insert two M5 x 12 mm screws (F) into column bracket of tube assembly (A) (see figure 5.1). Leave approximately 3/16" of thread exposed (see figure 5.2).

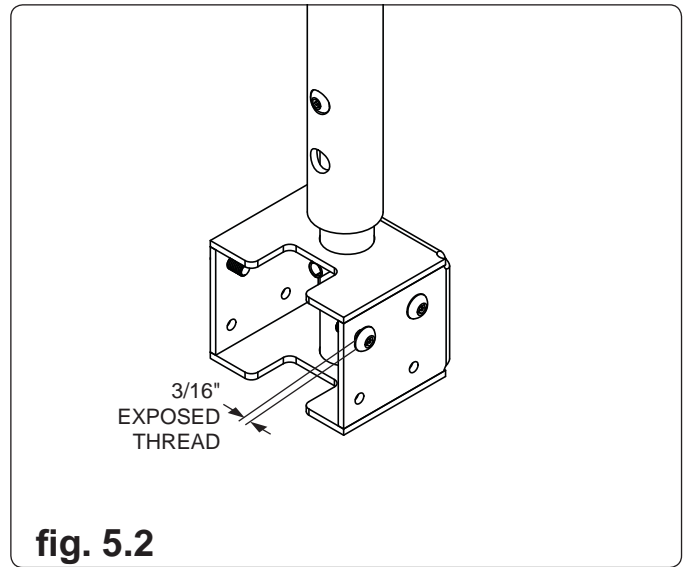
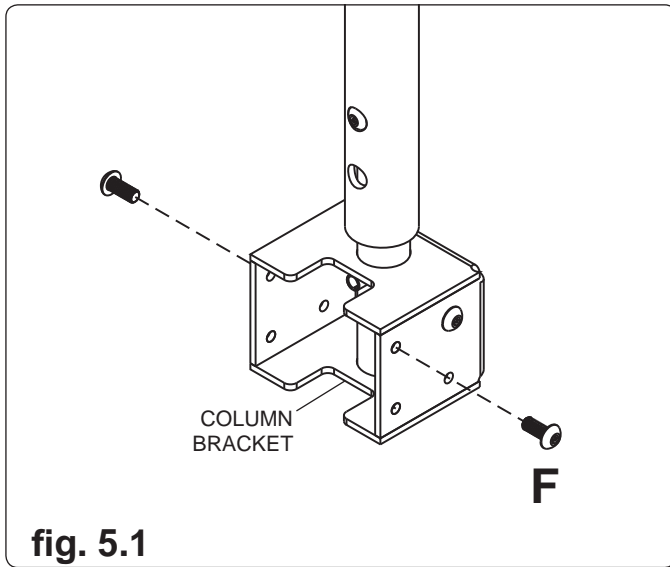

- 6 Hook tilt bracket (C) onto column bracket (see figure 6.1). Then secure with two M5 screws (F) (see figure 6.2). Adjust tilt (20° forward and 5° back) and swivel to desired position. Tighten all screws using security allen wrench (G).  
**Note:** Cable ties (Q) are provided for optional cord management along tube.

## ⚠ WARNING

- Always use an assistant or mechanical lifting equipment to safely lift and position the LCD screen.

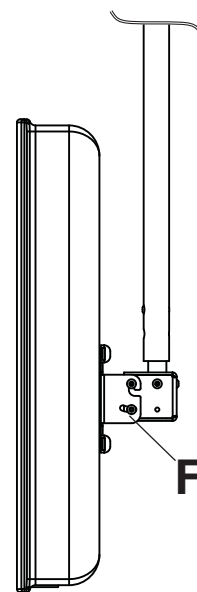
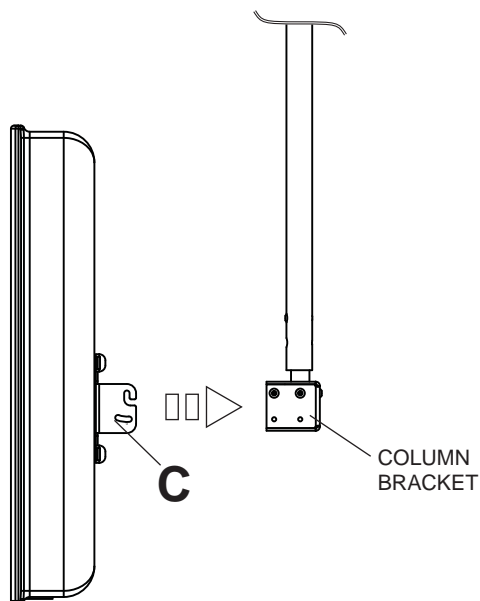

# Installation of Screen in the Horizontal Position

- 5 Insert two M5 x 12 mm screws (F) into column bracket of tube assembly (A) (see figure 5.1). Leave approximately 3/16" of thread exposed (see figure 5.2).

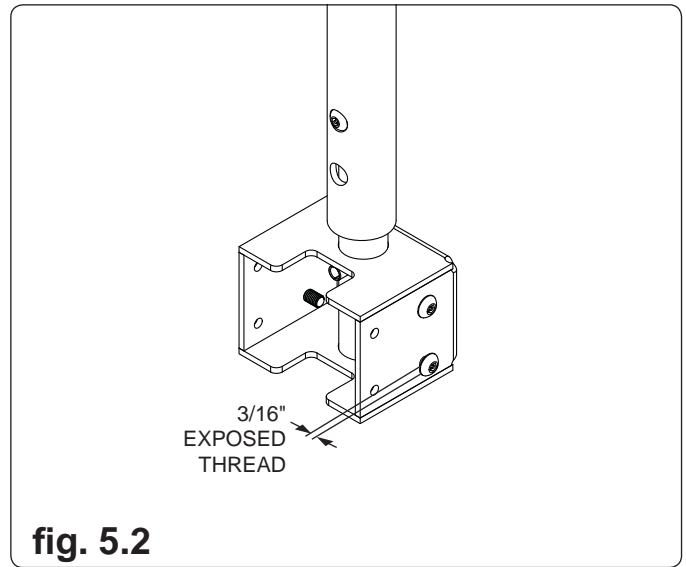
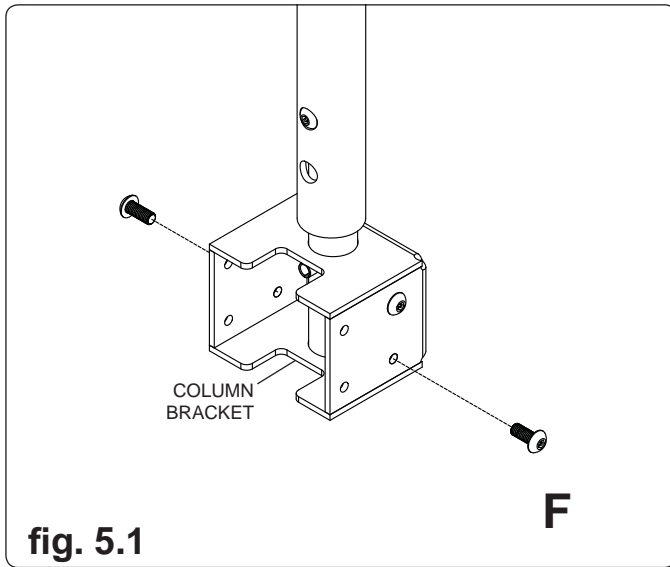

- 6 Hook tilt bracket (C) onto column bracket (see figure 6.1). Secure with two M5 screws (F) (see figure 6.2). Adjust tilt (20° forward and 5° back) and swivel to desired position. Tighten all screws using security allen wrench (G).  
**Note:** Cable ties (Q) are provided for optional cord management along tube.

## ⚠ WARNING

- Always use an assistant or mechanical lifting equipment to safely lift and position the LCD screen.

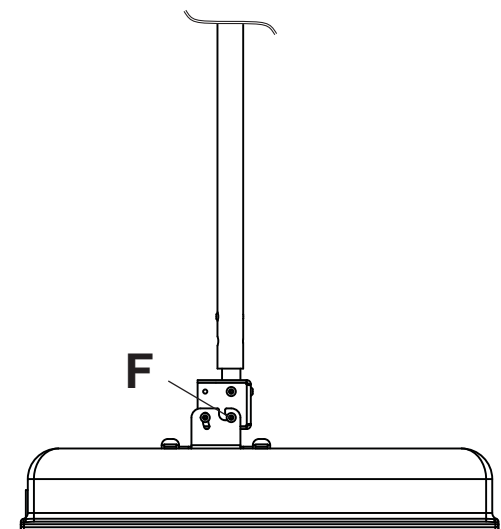
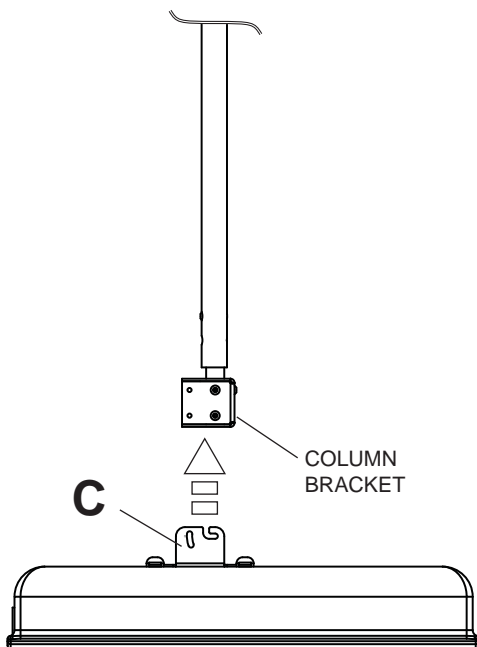

**fig. 6.1**

**fig. 6.2**