

90° USB 3.0 Type A Female-to-Female Module

Package Include:

A. 90° USB Module, 1 Piece



Features and Benefits

- Ideal for high-speed computers, notebooks, servers, and peripheral devices, external and portable storage hard drives, flash based thumb drives, etc.
- 90° degree USB module design for easy cable management
- USB 3.0 and backwards compatible to V1.1 and V2.0
- Data rate transmission of up to 5 Gbps; 5 meters maximum
- Compatible with most ICC's faceplates, blank patch panels, and decorex inserts*
- Due to space/port constraints within some of our 2/3/4/6/8/9/12 ports faceplates, we recommend for you to use the bottom port(s) for best fitting
- High-density snap-in keystone module

Not compatible with ICC's angled faceplates, angled elite bezels, and surface mount box (IC107DA, IC107A, and IC108B)

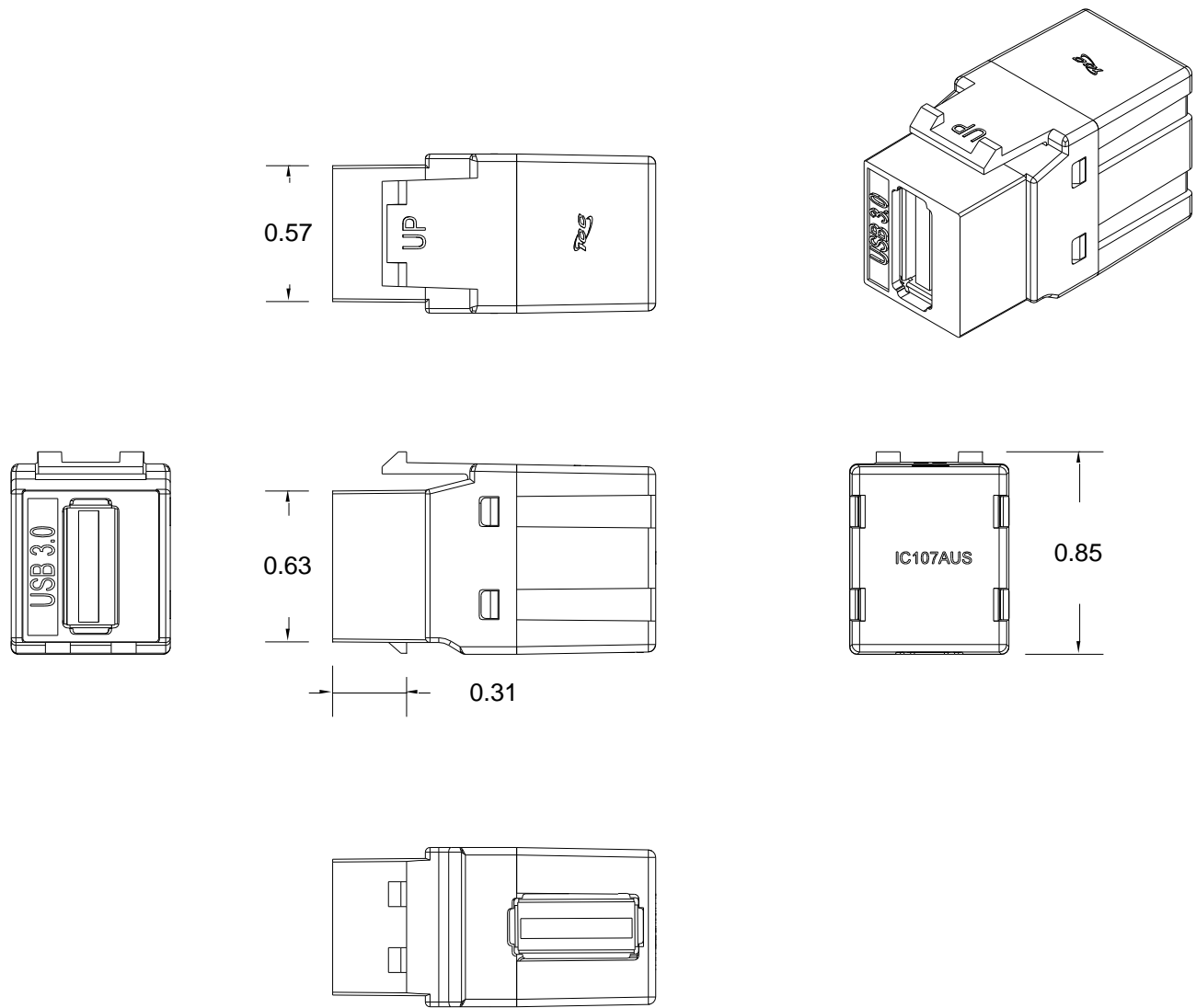

NOTE: UNLESS OTHERWISE SPECIFIED

1. Housing Material:

A. Housing: ABS+PC UL 94V-0

2. Color: WH-White

3. USB Adapter:

A. Version 3.0

B. Electrical Performance:

- High Voltage Test: DC/300V
- Insulation Resistance: <math><20\text{M}\Omega</math>
- Connection Resistance: <math><2\Omega</math>