



SMP5CTX Series - Installation Guide

Overview:

These units convert a 115VAC or 230VAC, 50Hz/60Hz input into a regulated 12VDC or 24VDC output up to 4 amps of continuous load current (see specifications).

SMP5CTX Series Power Supply Configuration Reference Chart:

Altronix Model Number	Accessory Power Distribution Module(s)	Number of Outputs	Fused Outputs	PTC Outputs	Individual Output Rating (amp)	Supervised	115VAC/230VAC Input Current (amp)	12/24VDC Total Output Current (amp)
SMP5CTX	-	1	-	-	-	-	0.95 / 0.5	4
SMP5PMCTX	-	1	-	-	-	x	0.95 / 0.5	4
SMP5PMCTXX	-	1	-	-	-	x	0.95 / 0.5	4
SMP5PMP4	PD4	4	x	-	3.5	x	0.95 / 0.5	4
SMP5PMP4CB	PD4CB	4	-	x	2.5	x	0.95 / 0.5	4
SMP5PMP8	PD8	8	x	-	3.5	x	0.95 / 0.5	4
SMP5PMP8CB	PD8CB	8	-	x	2.5	x	0.95 / 0.5	4
SMP5PMP16	PD16W	16	x	-	3.5	x	0.95 / 0.5	4
SMP5PMP16CB	PD16WCB	16	-	x	2.5	x	0.95 / 0.5	4

Specifications:

Input:

- Universal 115/230VAC input.

Battery Backup:

- Maximum charge current 0.5 amp.
- Filtered and electronically regulated outputs.
- Built-in charger for sealed lead acid or gel type batteries.
- Automatic switch over to stand-by battery when AC fails (zero voltage drop).

Features:

- AC input and DC output LED indicators.
- Short circuit and thermal overload protection.
- Complete with power supply, power distribution module (when applicable), enclosure, cam lock & battery leads.
- Power on-off switch.

Supervised Models Only:

- AC fail supervision (form “C” contacts).
- Low battery supervision (form “C” contacts).

Power Supply Voltage Output Specifications: *

Output VDC	Switch Position	Max. Load DC
12VDC	SW1 - Closed (Fig. 1b, pg. 3)	4 amp
24VDC	SW1 - Open (Fig. 1b, pg. 3)	4 amp

*Specified at 25° C ambient.

Installation Instructions:

The unit should be installed in accordance with The National Electrical Code and all applicable Local Regulations.

1. Mount the unit in the desired location.
2. Set SW1 on the power supply board to the desired DC output voltage (*Power Supply Voltage Output Specification Chart*).
3. Connect AC power to the terminals marked [L & N].

Use 18 AWG or larger for all power connections (Battery, DC output).

Use 22 AWG to 18 AWG for power-limited circuits (AC Fail/Low Battery reporting).

Keep power-limited wiring separate from non power-limited wiring (115/230VAC / 60Hz Input, Battery Wires).

Minimum 0.25” spacing must be provided.

CAUTION: Do not touch exposed metal parts. Shut branch circuit power before installing or servicing equipment.

There are no user serviceable parts inside. Refer installation and servicing to qualified service personnel.

4. Connect devices to be powered:
 - a. For Power Supply Board: connect to the terminals marked [– DC +].
 - b. For Power Distribution Module(s): connect devices to be powered to the terminal pairs 1 to 4 marked [1P & 1N through 4P & 4N] (Fig. 2, pg. 4) or 1 to 8 marked [1P & 1N through 8P & 8N] (Fig. 3, pg. 4) or 1 to 16 marked [1P & 1N through 16P & 16N] (Fig. 4, pg. 4), carefully observing correct polarity.

Note: Measure output voltage before connecting devices. This helps avoiding potential damage.

Note: Power switch is used to disconnect the L (HOT) terminal from the rest of the board. When servicing the unit, AC mains should be removed.
5. When using stand-by batteries, they must be lead acid or gel type. Connect battery to the terminals marked [– BAT +] (battery leads included). Use two (2) 12VDC batteries connected in series for 24VDC operation.
Note: When batteries are not used, a loss of AC will result in the loss of output voltage.
6. Connect appropriate signaling notification devices to AC Fail & Low Bat supervisory relay outputs marked [NC, C, NO] (Fig. 1a, pg. 3).

LED Diagnostics:

Red (DC)	Green (AC)	Power Supply Status
ON	ON	Normal operating condition
ON	OFF	Loss of AC. Stand-by battery supplying power
OFF	ON	No DC output
OFF	OFF	Loss of AC. Discharged or no stand-by battery. No DC output.

Terminal Identification:

Power Supply Board:

Terminal Legend	Function/Description
L, G, N	Connect 115VAC/230VAC to these terminals: L to Hot, N to Neutral.
– DC +	12VDC / 24VDC @ 4 amp continuous non power-limited output.
AC FAIL NC, C, NO	Used to notify loss of AC power, e.g. connect to audible device or alarm panel. Relay normally energized when AC power is present. Contact rating 1 amp @ 120VAC / 28VDC
Low Battery NC, C, NO.	Used to indicate low battery condition, e.g. connect to alarm panel. Relay normally energized when DC power is present. Contact rating 1 amp @ 120VAC / 28VDC. Low battery threshold: 12VDC output threshold set @ approximately 10.5VDC, 24VDC output threshold set @ approximately 21VDC.
– BAT +	Stand-by battery connections. Maximum charge rate 0.5 amp.

PD4/PD4CB/PD8/PD8CB/PD16W/PD16WCB - Power Distribution Module:

Terminal Legend			Function/ Description
PD4/PD4CB	PD8/PD8CB	PD16W/PD16WCB	
1P to 4P	1P to 8P	1P to 16P	Positive DC power outputs.
1N to 4N	1N to 8N	1N to 16N	Negative DC power outputs.

Fig. 1

CAUTION: De-energize unit prior to servicing. For continued protection against fire hazard replace fuse with the same type and rating.

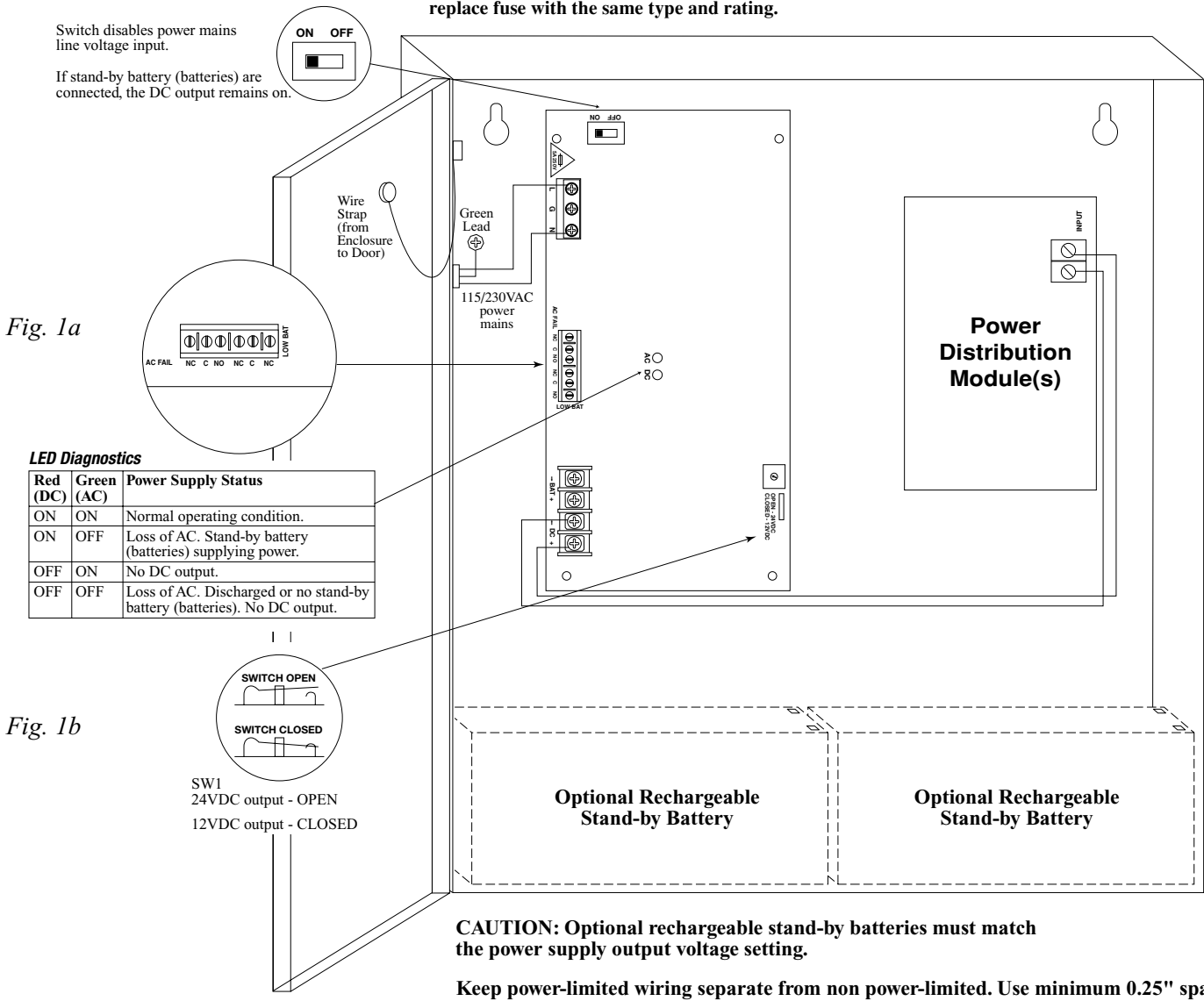

Fig. 1a

Fig. 1b

Power Distribution Module(s):

Fig. 2

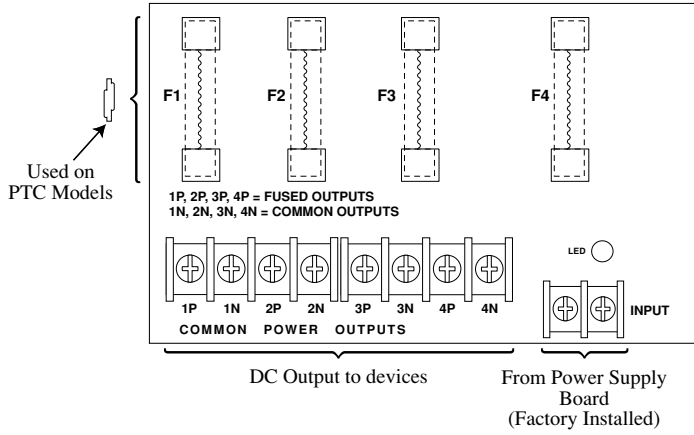

Fig. 3

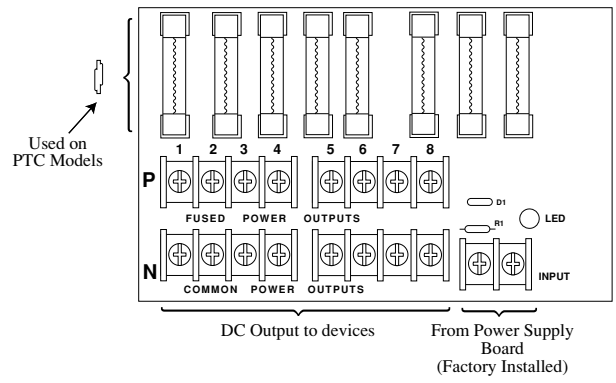
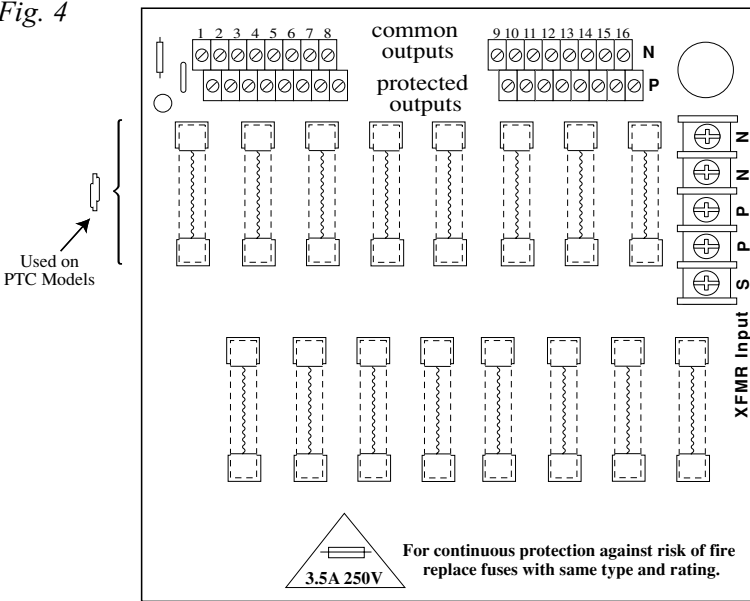

Fig. 4



Enclosure Dimensions for:

- SMP5PMCTX**
- SMP5PMP4**
- SMP5PMP4CB**
- SMP5PMP16CB**
- SMP5PMP8**
- SMP5PMP8CB**
- SMP5PMP16**
- SMP5PMP16CB**

13.5" x 13" x 3.25" (342.9mm x 330.2mm x 82.55mm)

Enclosure accommodates up to two (2) 12VDC/7AH batteries.

Also available to accommodate up to two (2) 12VDC/12AH batteries (please contact Altronix).

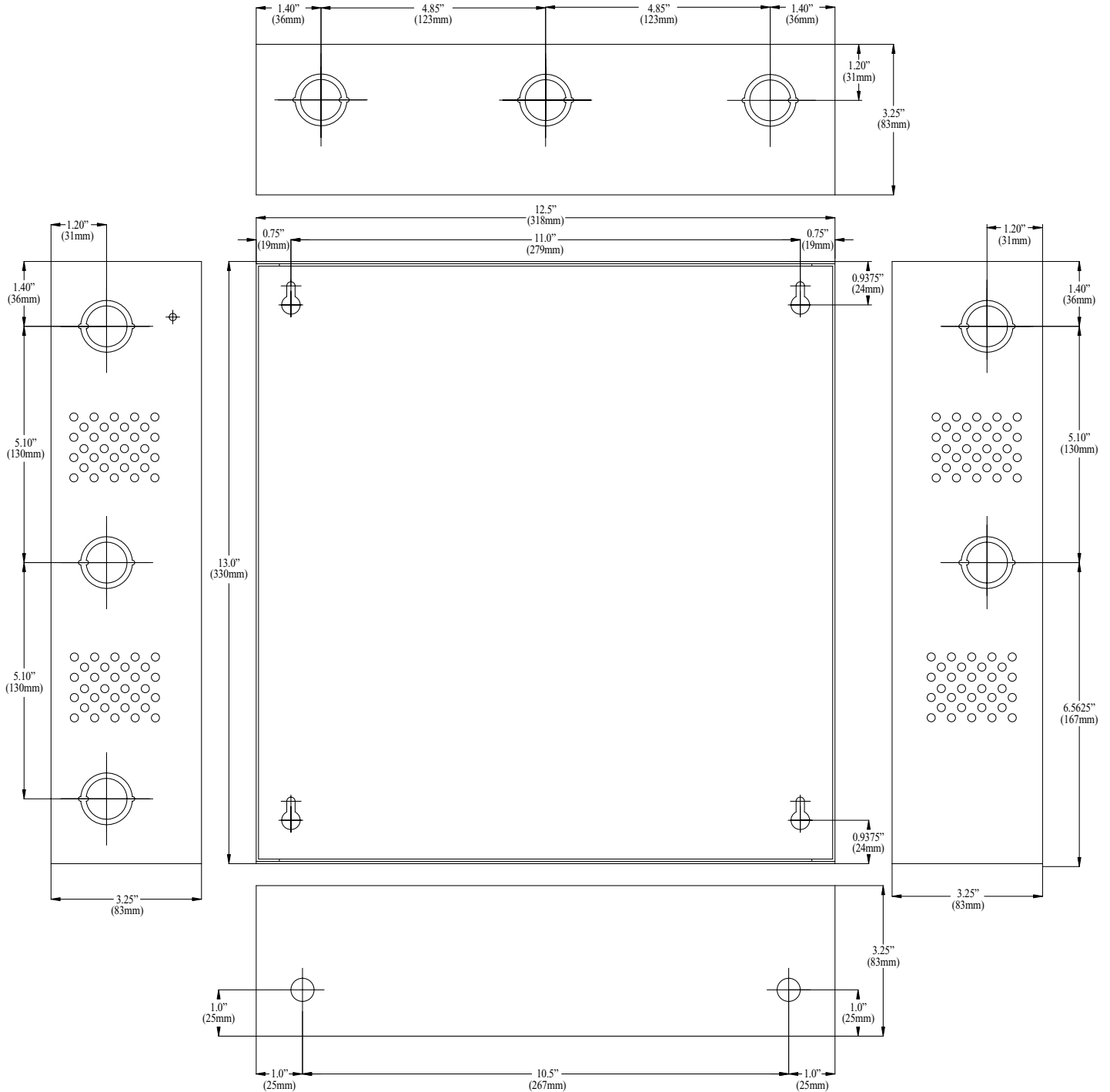

Enclosure Dimensions for:

• SMP5PMCTXX

15.5" x 12" x 4.5" (393.7mm x 304.8mm x 114.3mm)

Enclosure accommodates up to two (2) 12VDC/12AH batteries.

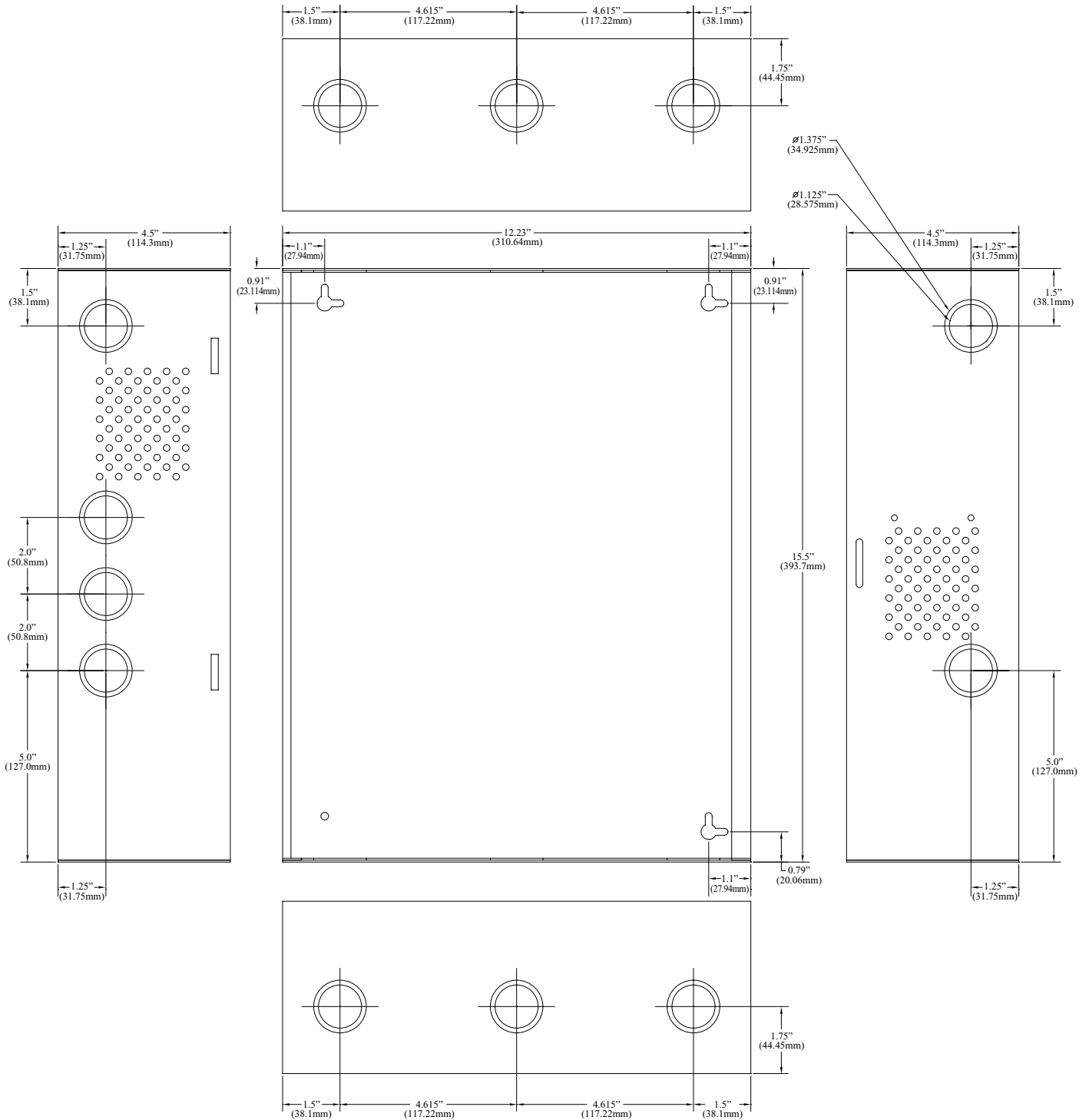

Notes:

Notes:

Altronix is not responsible for any typographical errors. Product specifications are subject to change without notice.

140 58th Street, Brooklyn, New York 11220 USA, 718-567-8181, fax: 718-567-9056
web site: www.altronix.com, e-mail: info@altronix.com, Made in U.S.A.
IISMP5PMCTX - Rev. 093003

G08N

- 8 -