

IP and PoE+ over Coax Solution

eBridgeTM **PLUS**

Installation Guide

Models Include:

eBridge8PCRM

- Eight (8) Channel Receiver

eBridge16PCRM

- Sixteen (16) Channel Receiver



Overview:

The eBridge8PCRM/16PCRM and eBridge1PCTX are CAT5 to Coax cable Ethernet adapters/Media converters that deliver data and power over the coax cable in a PoE+ compliant format. The paired set enables fast 10/100Base-T Ethernet digital communication to be transmitted over Coax cable. An eBridge8PCRM/16PCRM receiver is powered by a UL Listed limited power source, PoE midspan or endspan product, such as a NetWay8M and NetWay16M, and sends its power over the coax to the eBridge1PCTX transmitter under PoE protocol. This enables the eBridge8PCRM/16PCRM to be used in a managed manner, allowing for remote camera reset. The eBridge1PCTX in turn delivers that PoE+ compliant power to a PoE enabled camera or IP device. The eBridge8PCRM/16PCRM will not deliver power to non-compliant devices, thus avoiding damage to improperly connected analog cameras. These plug and play units facilitate system upgrades from analog to IP cameras/devices utilizing existing legacy Coax and eliminating the costs and labor associated with installing new network cabling. In addition, data transmission and power over the Coax is possible up to 457m in comparison to 100m Ethernet maximum distance (*see Maximum Length of Coax Type vs. Camera Power/PoE Class, pg. 3*). A maximum range from head end to the PoE camera/device is 657m taking into consideration that up to 100m of structured cable may be deployed at each end.

Features:

Agency Listings:

- UL/CUL Listed for Information Technology Equipment (UL 60950-1).
- CE approved.
- C-Tick compliant.

Input:

- Powered by a UL Listed limited power source, PoE midspan or endspan.

Ethernet:

- Connectivity: RJ45, auto-crossover.
- Wire type: 4-pair CAT5 or better structured cable.
- Distance: up to 100m.
- Speed: 10/100BaseT, half/full duplex, auto negotiation. PoE compliant to IEEE 802.3af (15W) and PoE+ compliant to IEEE 802.3at (30W) Delivered to camera by eBridge1PCTX. Power provided by eBridge8PCRM/16PCRM to eBridge1PCTX by PoE protocol.
- Throughput is rated to pass 25mbps of data at distances up to 457m. With proper headend equipment, this supports Megapixel, HD720, HD1080.

Coax:

- Distance: up to 457m (*see Maximum Length of Coax Type vs. Camera Power/PoE Class, pg. 3*) for power delivery of coax.
- Connectivity: BNC, RG-59/U or similar.

LED Indicators:

- eBridge8PCRM (16PCRM):
Blue LED - Coax link connection.
Green - PoE ON.
Green - Power ON.
- eBridge8PCRM/16PCRM and eBridge1PCTX:
Yellow and Green LED (RJ45) IP Link status, 10/100Base-T/active.

LED Indicators (cont'd):

- eBridge1PCTX:
Blue LED - Coax link connection.
Green LED - PoE from eBridge8PCRM/16PCRM.

Environmental:

- **Operating Temperature:**
eBridge8PCRM/16PCRM:
-4°F to 120.2°F (-20°C to +49°C).
eBridge1PCTX: -4°F to 120.2°F (-20°C to +49°C).
- **Storage Temperature:**
-22° to 158°F (-30° to +70°C) Storage.
- Humidity: 20 to 85%, non-condensing.

Functions:

- Auto detection and protection of legacy non-PoE cameras/devices.

Applications:

- Retrofit digital IP cameras in an analog CCTV installation.
- Works with Megapixel, HD720, HD1080 and VGA (SD) cameras (*see note, pg. 2*).
- Extend Network link distance in an industrial environment over 610m (*see note, pg. 2*).
- Upgrade deployed CCTV Coax to a digital network in Retail, Hospitality, Arenas, Casinos, Airports, Schools, Hospitals, Transportation, etc.

Mechanical:

- Dimensions (H x W x D approx.):
eBridge8PCRM/16PCRM:
1.625" x 19.125" x 8.5" (42mm x 486mm x 216mm)
eBridge1PCTX:
1" x 2.5" x 4.375" (25.4mm x 63.5mm x 111.125mm)

Installation Instructions:

Wiring methods shall be in accordance with the National Electrical Code/NFPA 70/ANSI, and with all local codes and authorities having jurisdiction. Wiring should be UL Listed and/or Recognized wire suitable for the application.

eBridge8PCRM/16PCRM is not intended to be connected to outside plant leads and should be installed indoors within the protected premises. The eBridge8PCRM/16PCRM and eBridge1PCTX are intended for indoor use only.

Elevated Operating Ambient - If installed in a closed or multi-unit rack assembly, the operating ambient temperature of the rack environment may be greater than room ambient. Therefore, consideration should be given to installing the equipment in an environment compatible with the maximum ambient temperature (T_{ma}) specified by the manufacturer.

Reduced Air Flow - Installation of the equipment in a rack should be such that the amount of air flow required for safe operation of the equipment is not compromised. Do not obstruct any air vents on the unit. It is recommended to leave half space above and below the unit.

Mechanical Loading - Mounting of the equipment in the rack should be such that a hazardous condition is not achieved due to uneven mechanical loading.

Circuit Overloading - Consideration should be given to the connection of the equipment to supply circuit and the effect that overloading of the circuits might have on overcurrent protection and supply wiring. Appropriate consideration of equipment nameplate rating should be used when addressing this concern.

Reliable Earthing - Reliable earthing of rack-mounted equipment should be maintained. Particular attention should be given to supply connections other than direct connections to the branch circuit (e.g. use of power strips).

1. **eBridge8PCRM/16PCRM** installation:

- a. Attach mounting brackets to eBridge8PCRM/16PCRM unit for rack installation (Fig. 4, pg. 6).
Affix rubber pads to eBridge8PCRM/16PCRM for shelf installation (Fig. 5, pg. 6).
Unit should be located in proximity to ethernet switch/network, NVR or video server.
- b. Connect structured cable from ethernet midspan or endspan device to RJ45 jack marked [10/100BaseT] (Fig. 2, pg. 3).
- c. Connect Coax cable to BNC connector marked [Coax] (Fig. 1, pg. 3).

2. **eBridge1PCTX** installation:

- a. Secure unit to desired mounting surface with a proper fastening device utilizing the case's mounting hole.
Unit should be mounted in proximity of camera/device.
- b. Connect structured cable from IP camera/device to RJ45 jack marked [10/100BaseT] (Fig. 2, pg. 3).
- c. Connect Coax cable to BNC connector marked [Coax] (Fig. 2, pg. 3).

Note: The eBridge8PCRM/16PCRM is designed to accommodate Megapixel, HD720, HD1080 and VGA (SD) cameras. It is important to note that some high resolution and high frame rate cameras may demand faster headend processing ability, such as a PC graphics card to present a quality image. If the headend processing equipment is insufficient in speed, the image may show pixelation and latency. It is advisable to pretest system if unsure. Alternatively, frame rate and resolution may be reduced to accommodate system equipment.

Fig. 1

eBridge8PCRM

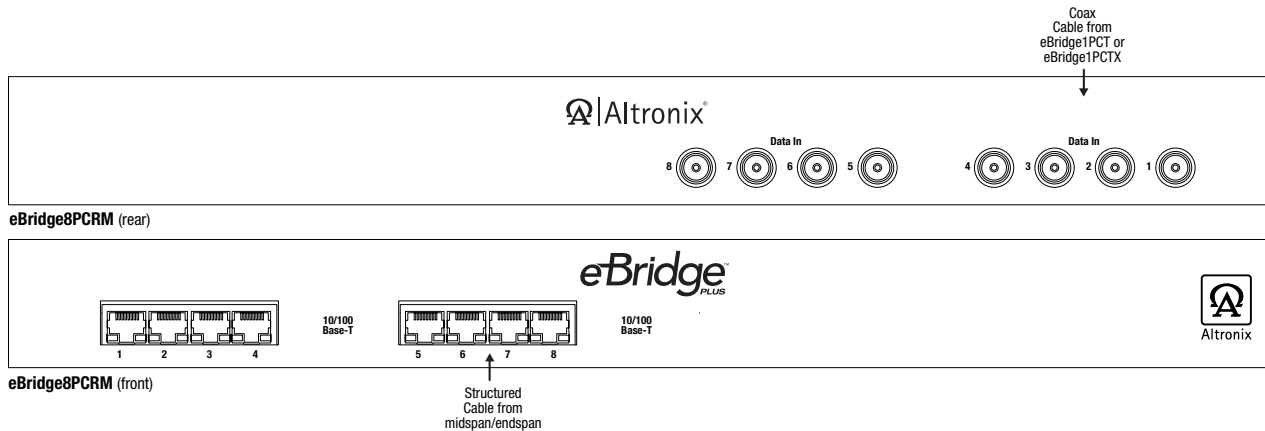

Fig. 1a

eBridge16PCRM

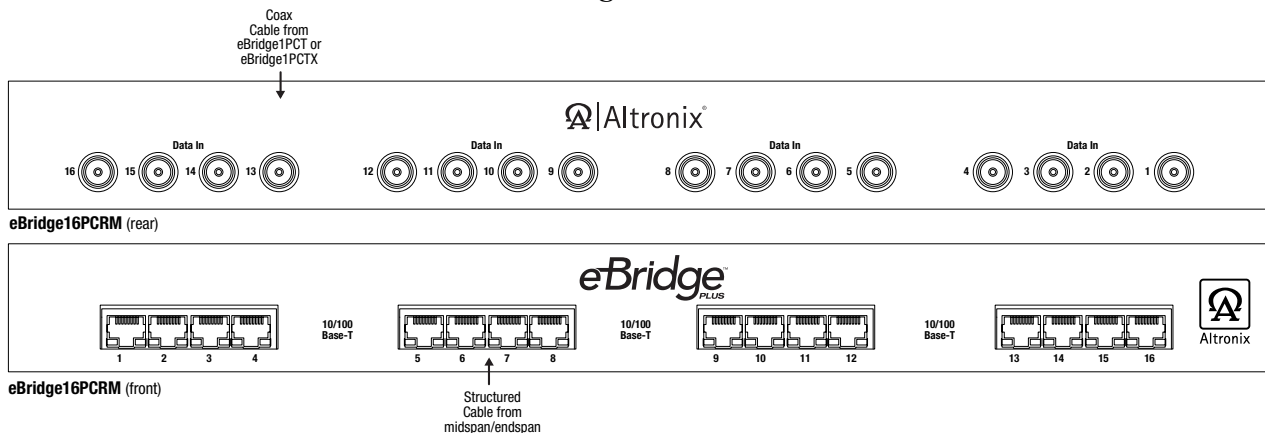
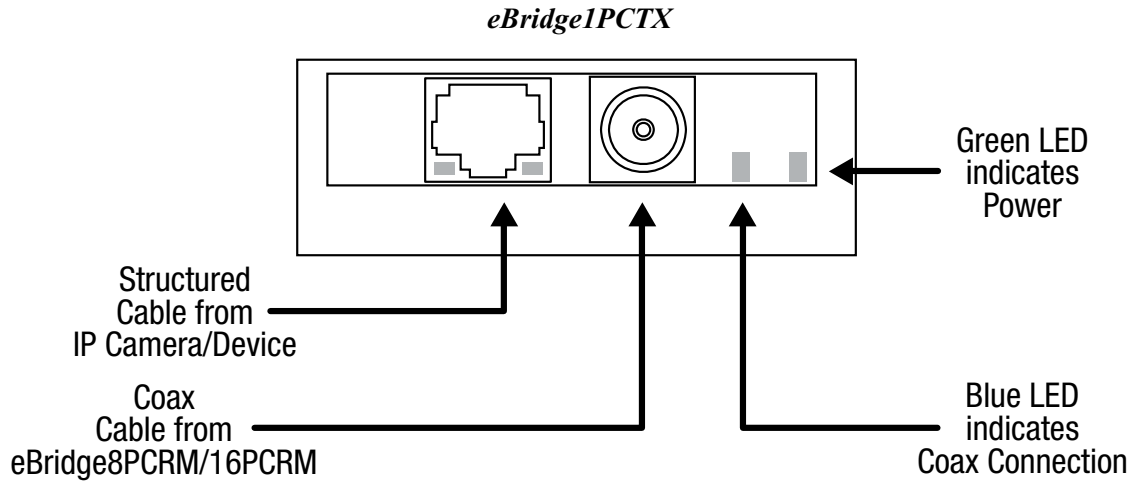

Fig. 2



Multiple PoE camera connection:

eBridge8PCRM shown. eBridge16PCRM is similar, with twice as many channels.

Fig. 3

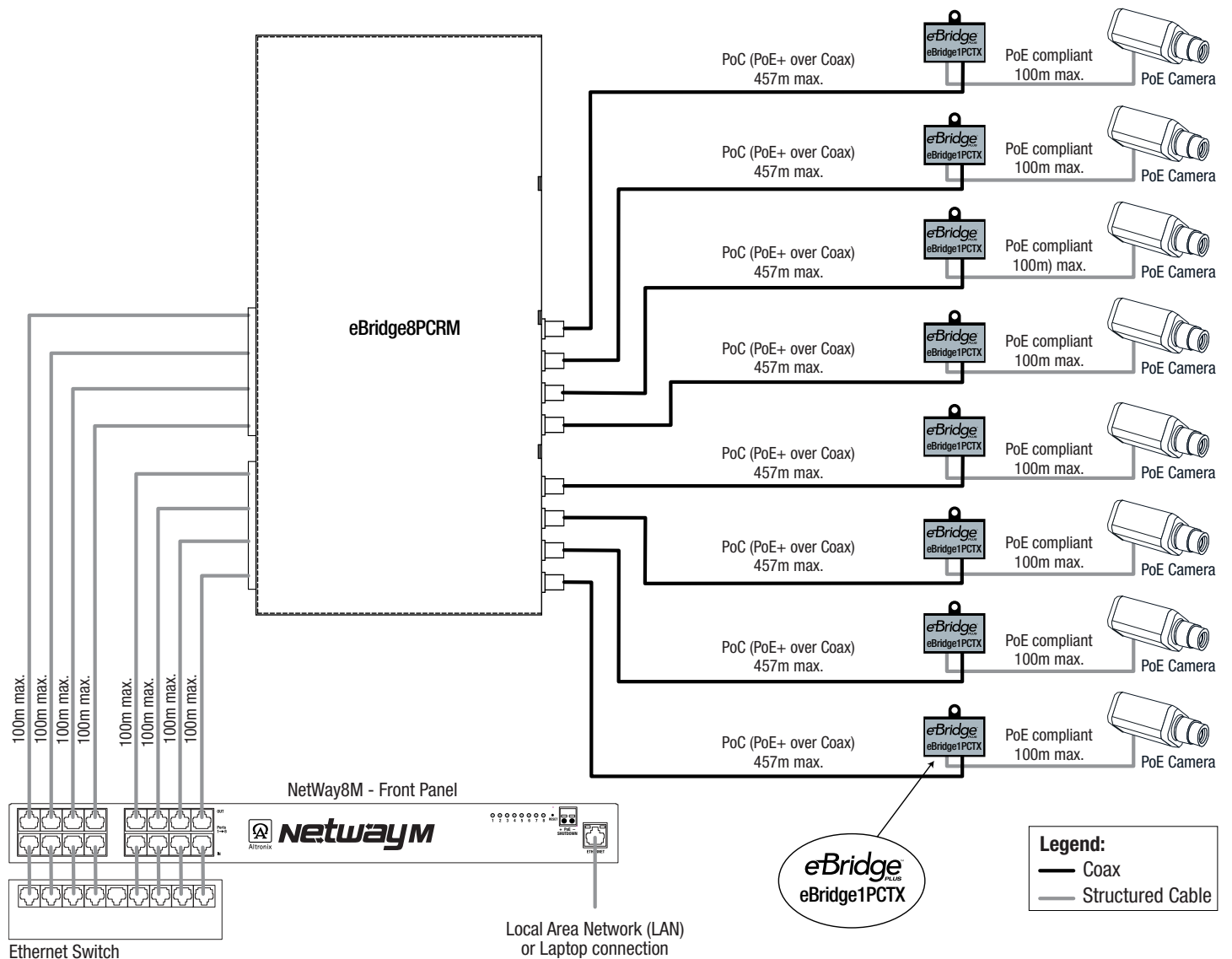

Technical Specifications:

Parameter	Description
Connections	BNC for Coax link. RJ45 for ethernet link.
Input power requirements	Midspan or endspan port connected.
Indicators	Blue: Coax Link. Yellow (RJ45 connector): On - Link, Off - No Link, Blinking - Activity. Green (RJ45 connector): On - 100Base-TX, Off - 10Base-T. Green: Power.
Environmental Conditions	Operating Ambient Temperature: UL60950-1 eBridge8PCRM/16PCRM: -4°F to 120.2°F (-20°C to +49°C). eBridge1PCTX: - 4°F to 120.2°F (- 20°C to +49°C). Relative humidity: 20 to 85%, non-condensing. Storage Temperature: - 22° to 158°F (- 30° to +70°C) Storage. Operating Altitude: -1000 to 6,561.679 ft. (-304.8 to 2000m).
Regulatory Compliance	UL/CUL Listed for Information Technology Equipment (UL 60950-1). CE approved. C-Tick compliant.
Weights (approx.)	eBridge8PCRM: Product: 5.8 lbs. (2.63 kg), Shipping: 7.8 lbs. (3.54 kg) eBridge16PCRM: Product: 7.2 lbs. (3.27 kg), Shipping: 9.2 lbs. (4.17 kg)

Maximum Length of Coax Type vs. Camera Power/PoE Class:

Camera Power/ PoE Class	RG59/U (23AWG)	RG59/U (22AWG)	RG59/U (20AWG)	RG59/U (18AWG)	RG6/U (18AWG)
	Max. Length (meters)				
13W/0	260.64m	335.28m	457.20m+	457.20m+	457.20m+
4W/1	457.20m+	457.20m+	457.20m+	457.20m+	457.20m+
6.5W/2	457.20m+	457.20m+	457.20m+	457.20m+	457.20m+
13W/3	260.64m	335.28m	457.20m+	457.20m+	457.20m+
19W	260.64m	335.28m	457.20m+	457.20m+	457.20m+
25W	260.64m	335.28m	457.20m+	457.20m+	457.20m+

Mounting Options:

Rack Mount Installation

- 1- Remove and discard factory installed screws from both sides of rack chassis (Fig. 4a).
- 2- Install mounting brackets (A) on the left and right side of rack chassis using the four (4) flat head screws (B) (included) (Fig. 4b).
- 3- Place unit into desired EIA 19" rack position and secure with mounting screws (not included) (Fig. 4c).

Fig. 4

Fig. 4a

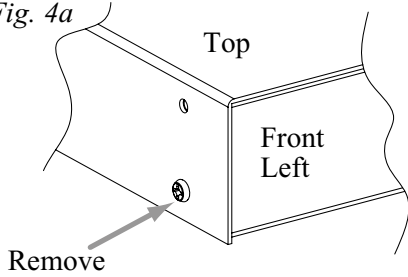

Fig. 4b

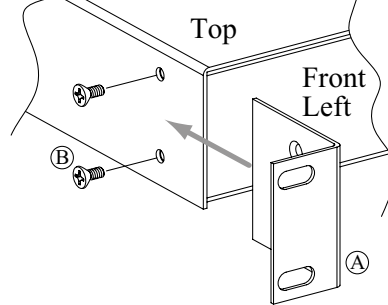
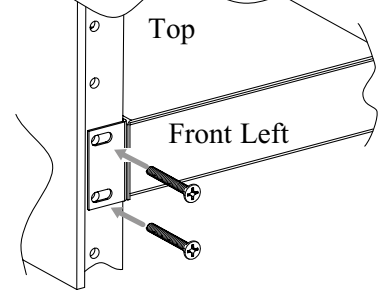

Fig. 4c



Shelf Installation

- 1- Position and affix rubber pads (C) (included) at each corner on the bottom of the unit (Fig. 5).
- 2- Place unit in desired location.

Fig. 5

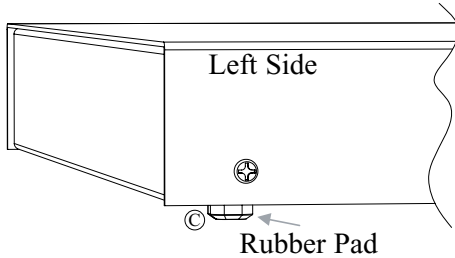

Mounting Hardware (Included):

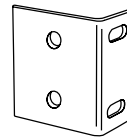

(A) Two (2) mounting brackets



(B) Six (6) flat head screws for mounting brackets.



(C) Four (4) rubber pads.

Enclosure Dimensions (H x W x D approximate):

1.625" x 19.125" x 8.5" (42mm x 486mm x 216mm)

eBridge16PCRM shown. eBridge8PCRM is similar.

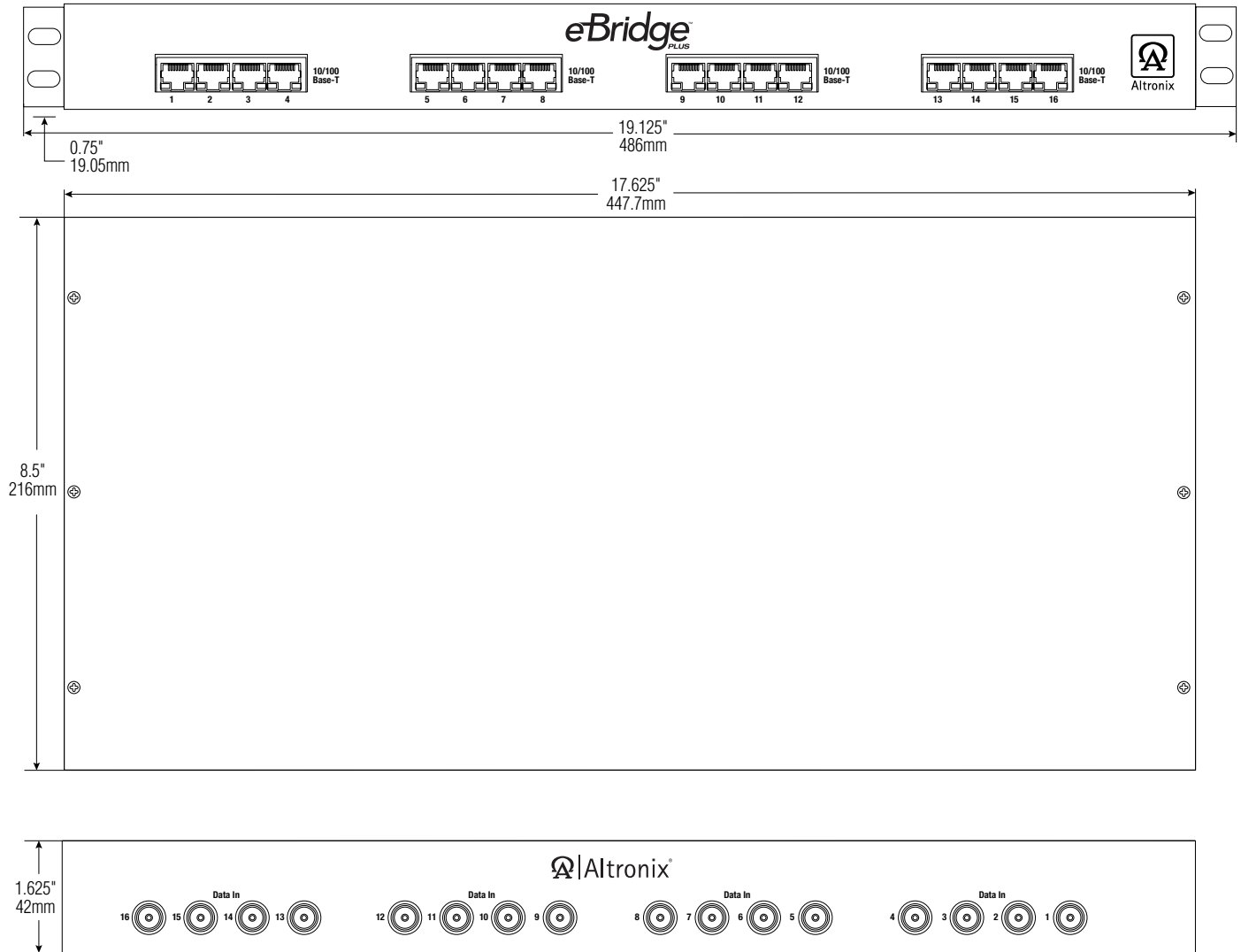

Notes:

Altronix is not responsible for any typographical errors.

140 58th Street, Brooklyn, New York 11220 USA, 718-567-8181, fax: 718-567-9056
website: www.altronix.com, e-mail: info@altronix.com, Lifetime Warranty, Made in U.S.A.
11eBridge8PCRM/16PCRM

G25N

- 8 -



eBridge8PCRM/16PCRM