

VERTILINE

CCTV Isolated Rack Mount Power Supplies

Installation Guide

Models Include:

Vertiline8i

- 24VAC or 28VAC @ 8 amp
- Eight (8) fuse protected electronically isolated outputs

Vertiline16i

- 24VAC or 28VAC @ 16 amp
- Sixteen (16) fuse protected electronically isolated outputs

Vertiline8Di

- 24VAC or 28VAC @ 8 amp
- Eight (8) PTC protected electronically isolated outputs

Vertiline16Di

- 24VAC or 28VAC @ 16 amp
- Sixteen (16) PTC protected electronically isolated outputs



Rev. 031808



More than just power.™

Overview:

Altronix Vertiline AC Isolated CCTV Rack Mount Power Supplies provide 8 or 16 camera channels in a space saving 1U EIA 19" rack mount chassis which may be rack, wall or shelf mounted. The units feature individually selectable 24VAC and/or 28VAC power outputs.

Specifications:

Input:

- Selectable 115VAC 60 Hz or 230VAC 50/60 Hz input.

Output:

- Eight (8) or sixteen (16) individually selectable 24VAC or 28VAC power outputs with OFF position.
- Maximum 1 amp per output.
- Individual electronically isolated outputs.
- Eight (8) or sixteen (16) power LED indicators.
- External automotive blade fuses or PTC protected outputs.
- Surge suppression.

Features:

- Illuminated power disconnect circuit breaker with manual reset.
- Removable terminal blocks with locking screw flange.
- Ease of installation saves time and eliminates costly labor.

Mechanical:

- Units can be rack, wall or shelf mounted.
- Modular 1U standard EIA 19" rack mount chassis
- Enclosure Dimensions (H x W x D approx.): 1.625" x 19.125" x 8.5" (41.3mm x 486mm x 216mm).

Eight (8) & Sixteen (16) Output Rack Mount Configuration Reference Chart:

| Altronix Model Number | Output Voltage (VAC) | Total Output Current (Power) | Number of Outputs | Output Protection | Class 2 Rated Power-Limited Output Protection | Current (max. per output) | Fuse Rating | 115VAC 60Hz Input Current | 230VAC 50/60Hz Input Current | Agency Listings | UL Listings and File Numbers |
|-----------------------|----------------------|------------------------------|-------------------|-------------------|---|---------------------------|-------------|---------------------------|------------------------------|---|---|
| Vertiline8i | 24VAC or 28VAC | 8 amp | 8 | Fused | - | 3 amp | 3 amp | 2.5 amp | 1.5 amp |  | UL Listed for Commercial CCTV Equipment (UL 2044). CUL Listed - CSA Standard C22.2 No.1-04, Audio, Video and Similar Equipment. |
| Vertiline8Di | 24VAC or 28VAC | 8 amp | 8 | - | PTC | 2.5 amp | - | | | | |
| Vertiline16i | 24VAC or 28VAC | 16 amp | 16 | Fused | - | 3 amp | 3 amp | 5 amp | 2.5 amp | | |
| Vertiline16Di | 24VAC or 28VAC | 16 amp | 16 | - | PTC | 2.5 amp | - | | | | |

WARNING: To reduce the risk of fire or electric shock, do not expose the unit to rain or moisture. This installation should be made by qualified service personnel and should conform to the National Electrical Code and all local codes.

Installation Instructions:

1. Set the input voltage selector switch located on the left side of the Vertiline unit for 115VAC or 230VAC operation (*Fig. 1c, pg. 4*).
2. Attach mounting brackets to Vertiline unit for rack or wall mount installation (*Figs. 4-5, pg. 7*). Affix rubber pads to Vertiline for shelf installation (*Fig. 6, pg. 7*).
3. Secure the unit in a rack, mount unit to a wall or place unit on a shelf as desired (unit should be spaced at least 3" from any video monitors). When installing the unit in a rack, allow for one half of a U spacing above the unit for ventilation.
4. Plug the grounded AC line cord (included) into the IEC 320 connector of the Vertiline unit (*Fig. 1f, pg. 4*). Insert the plug end of the line cord into a grounded AC receptacle.
5. Set illuminated master power disconnect circuit breaker to the (ON) position (*Fig. 3, pg. 6*).
6. Select 24VAC or 28VAC power output for cameras 1-8 for Vertiline8i and Vertiline8Di or cameras 1-16 for Vertiline16i and Vertiline16Di with the corresponding voltage adjustment switches (*Fig. 1b, pg. 4*).
7. Measure output voltage before connecting cameras. This helps avoiding potential damage. All terminals with common suffix (P) "1P, 2P ..." are the same polarity.

8. Set illuminated master power disconnect circuit breaker to the (OFF) position (*Fig. 3, pg. 6*).
9. Connect the power outputs of the terminals marked [1P & 1N] to the power inputs of camera 1 (*Fig. 2, pg. 5*). Repeat this step for each additional camera (Outputs 2-16). After wiring is completed, insert terminal block into the corresponding connector and secure by tightening the screws.
10. Upon completion of wiring, set illuminated master power disconnect circuit breaker to the ON (RESET) position (*Fig. 3, pg. 6*).
11. The power LEDs (Green) on the faceplate for Outputs 1-8 for Vertiline8i and Vertiline8Di or Outputs 1-16 for Vertiline16i and Vertiline16Di will illuminate when AC power is present (*Fig. 1a, pg. 4*). If all of the LEDs are OFF, there may be a complete loss of supply power to the Vertiline unit or the illuminated master power disconnect circuit breaker is in the OFF position.

To restore the power output for Vertiline8i or Vertiline16i:

- 1- Switch corresponding output voltage switch to the OFF position (*Fig. 1b, pg. 4*).
- 2- Eliminate the trouble condition.
- 3- Replace the corresponding automotive blade fuse.

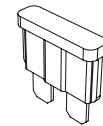

Automotive
Blade Fuse

Replace fuses with same type and rating:

Output fuses are rated @ 3 amp for all models.

- 4- Switch output voltage switch to the 24VAC or 28VAC position as desired (*Fig. 1b, pg. 4*).

To restore the power output for Vertiline8Di or Vertiline16Di:

- 1- Switch corresponding output voltage switch to the OFF position (*Fig. 1b, pg. 4*).
- 2- Eliminate the trouble condition.
- 3- Allow 1 minute for PTC to cool off.
- 4- Switch output voltage switch to the 24VAC or 28VAC position as desired (*Fig. 1b, pg. 4*).

Fig. 1

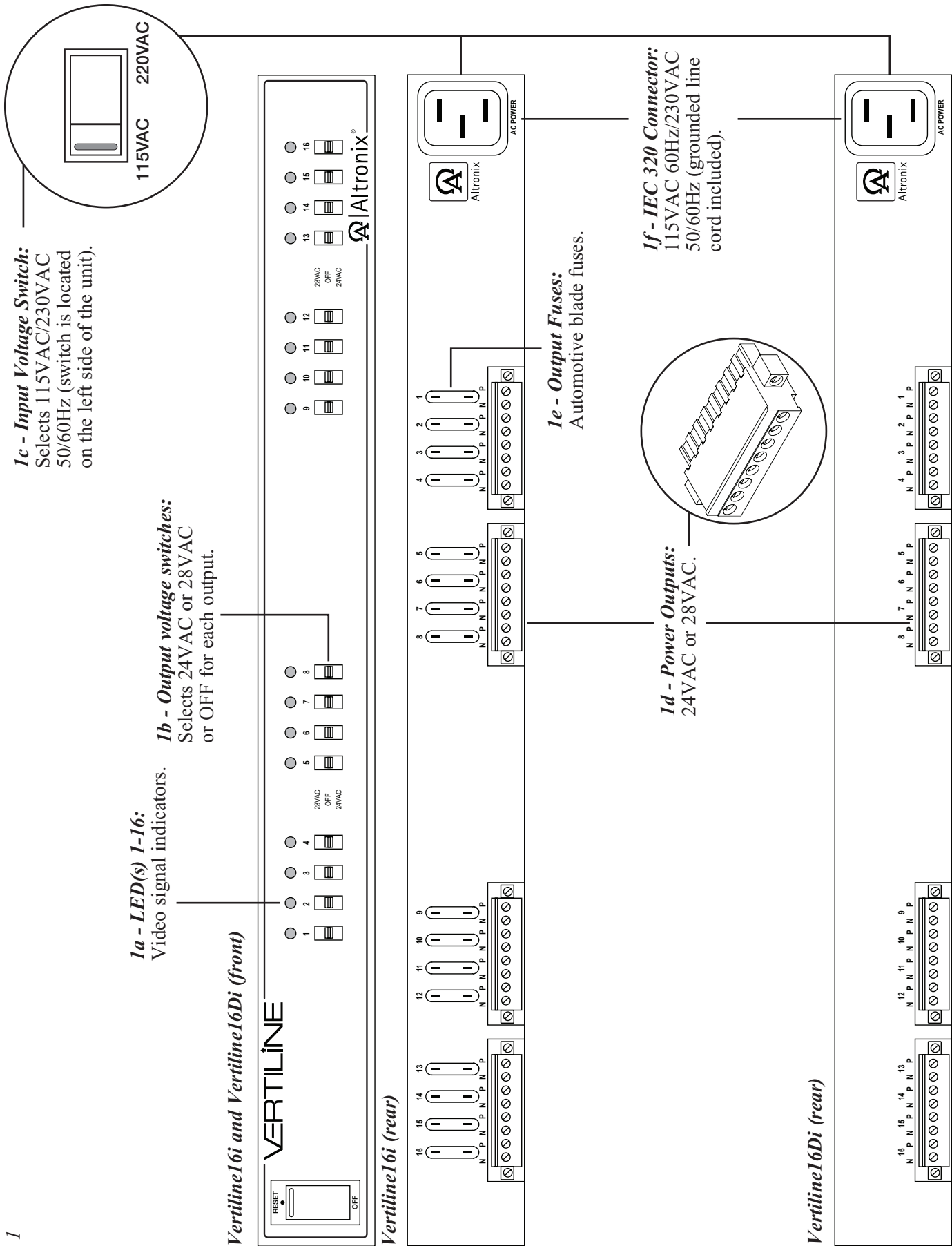

PTC protected models (Vertiline8Di and Vertiline16Di) do not have output fuses on the rear of rack mount chassis. The PTCs are located on the inside of the rack mount chassis.

Fig. 2

Typical Hookup:

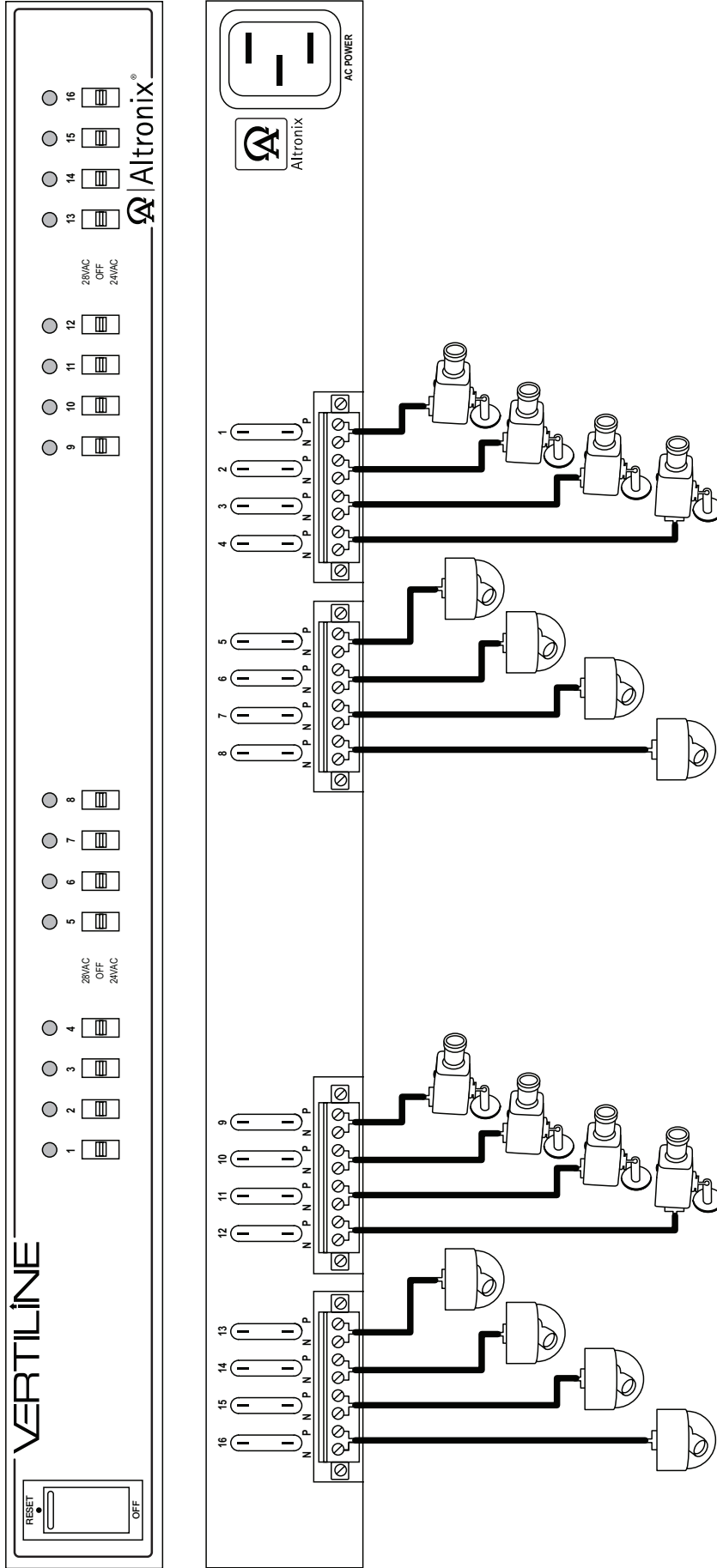



The lightning flash with arrow head symbol within an equilateral triangle is intended to alert the user to the presence of an insulated **DANGEROUS VOLTAGE** within the product's enclosure that may be of sufficient magnitude to constitute an electric shock.



The exclamation point within an equilateral triangle is intended to alert the user to the presence of important operating and maintenance (servicing) instructions in the literature accompanying the appliance.



CAUTION
RISK OF ELECTRIC SHOCK
DO NOT OPEN



CAUTION: To reduce the risk of electric shock do not open enclosure. There are no user serviceable parts inside. Refer servicing to qualified service personnel.

1U EIA 19" Rack Mount Chassis Mechanical Drawing & Dimensions (H x W x D):
1.625" x 19.125" x 8.5" (41.3mm x 486mm x 216mm)

REAR

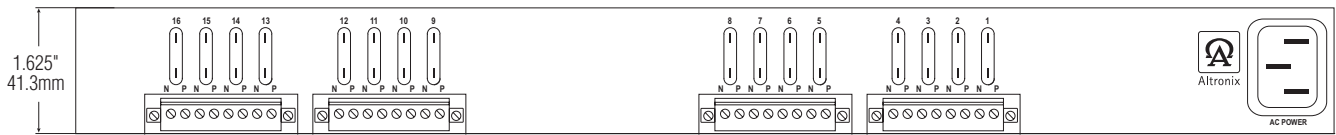

TOP & BOTTOM

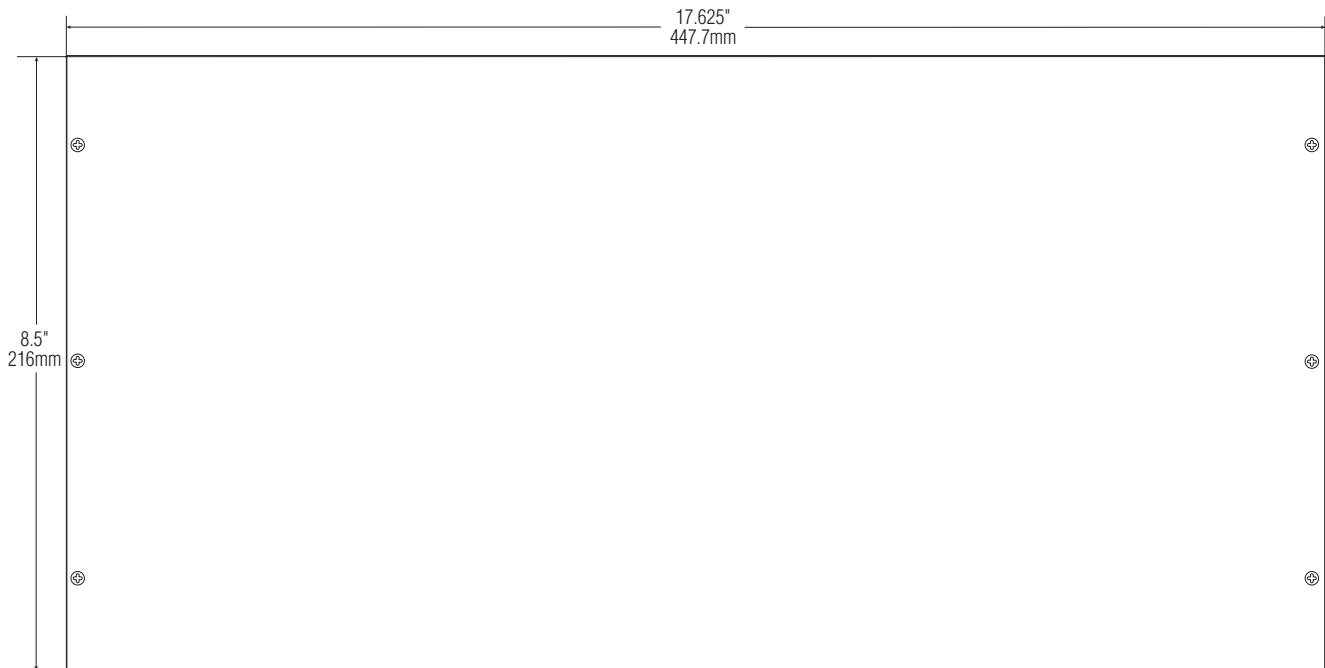

FRONT

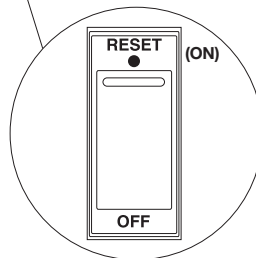
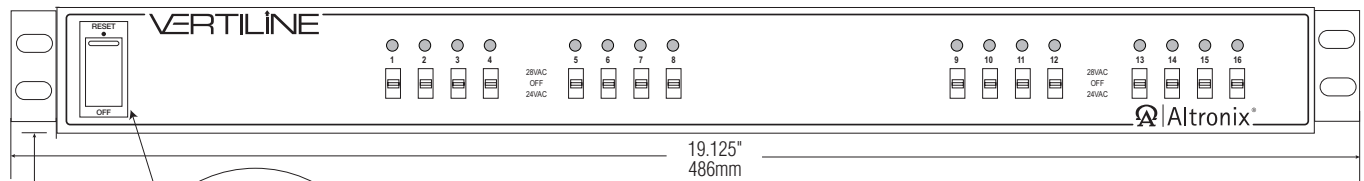

Fig. 3

Power switch with built-in circuit breaker:

OFF position - Switch not Illuminated. Outputs not powered.

RESET (ON) position - Switch illuminated. Outputs powered.

Circuit breaker tripped - Switch not Illuminated. Power LEDs on faceplate are not illuminated. Outputs not powered.

To reset circuit breaker set power switch to the ON (RESET) position (*Fig. 3, pg. 6*).

Mounting Options:

Rack Mount Installation

- 1- Remove factory installed screws from both sides of rack chassis (Fig. 4a).
- 2- Install mounting brackets (A) on the left and right side of rack chassis using the two (2) flat head screws (B) (included) (Fig. 4b).
- 3- Place unit into desired EIA 19" rack position and secure with mounting screws (not included) (Fig. 4c).

Fig. 4

Fig. 4a

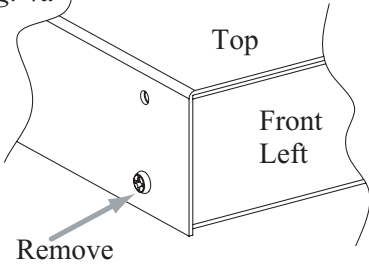

Fig. 4b

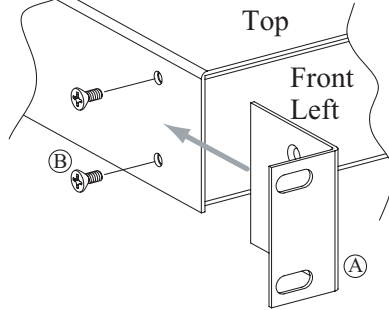
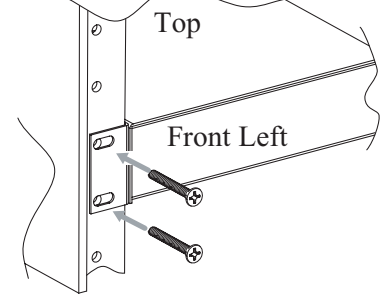

Fig. 4c



Wall Mount Installation

- 1- Install mounting brackets (A) on the left and right side of rack chassis using two (2) flat head screws (B) (included) (Fig. 5a).
- 2- Place unit at desired location and secure with mounting screws (not included) (Fig. 5b).

Caution: It is necessary to make sure mounting screws are securely fastened to a beam when installing.

Fig. 5

Fig. 5a

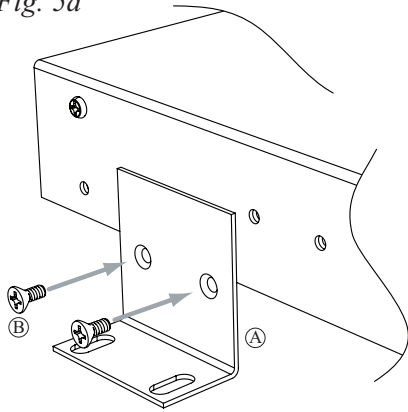
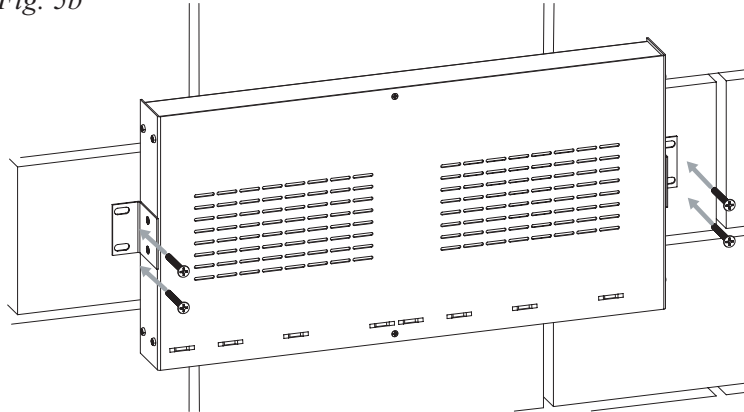

Fig. 5b



Shelf Installation

- 1- Position and affix rubber pads (C) (included) at each corner on the bottom of the unit (Fig. 6).
- 2- Place unit in desired location.

Fig. 6

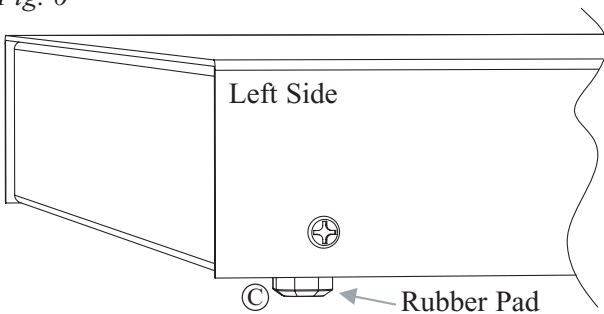

Mounting Hardware (Included):

(A) Two (2) mounting brackets

(B) Six (6) flat head screws for mounting brackets.

(C) Four (4) rubber pads.

Notes:

Altronix is not responsible for any typographical errors.

140 58th Street, Brooklyn, New York 11220 USA, 718-567-8181, fax: 718-567-9056
web site: www.altronix.com, e-mail: info@altronix.com, Lifetime Warranty, Made in U.S.A.
IIVertiline8i/Vertiline16iSeries

E29N

- 8 -



MEMBER

Vertiline8i/Vertiline16i