

BOSCH

Invented for life

LTC 9305 Series Indoor Housings



- ▶ Rugged cast aluminum construction - equivalent to 10 gauge steel
- ▶ Ceiling or wall mounted Installation
- ▶ Scratch-resistant polycarbonate window, easily replaceable
- ▶ Adjustable camera mounting system
- ▶ Attractive styling

The LTC 9305 Series are wall or ceiling mounted detention grade security housings designed for applications such as prisons, parking garages, and hospitals. These housings are ideal for applications requiring secure CCTV monitoring.

For maximum protection and durability, the lightweight cast aluminum design of the LTC 9305 Series housings provide the strength of 10 gauge steel with the superior strength-to-weight ratio of aluminum. The viewing window, constructed of 9.5 mm (0.37 in) clear polycarbonate material, treated with a scratch resistant coating, can be easily replaced. The removable cover provides access to the camera and is secured by a tamper-resistant screw. A special tool is provided for screw removal.

Attractively styled, these housings are designed to be mounted on the ceiling, on the wall horizontally, or on the wall vertically. A key lock on the access panel is available.

These housings will accept all 1/4-inch, 1/3-inch, and 1/2-inch format CCD cameras with fixed format lenses.

Installation/Configuration Notes

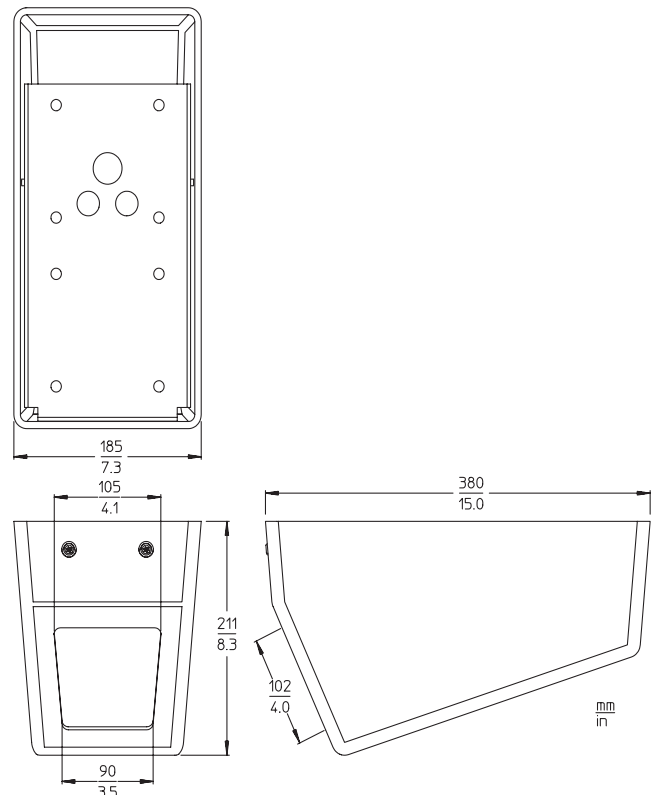

Technical Specifications

Models

LTC 9305/00	Clear 9.5 mm (0.37 in.) viewing window
LTC 9305/01	Key lock controlled access, 9.5 mm (0.37 in.) viewing window

Mechanical

Dimensions	See drawing
Color	Light gray
Weight	5.6 kg (12.3 lb)
Mounting	8 holes 10 mm (0.41 in.) in top
Cable entry	1 x 21 mm (3/4 in.) knockout in top 2 x 13.5 mm (1/2 in.) knockouts in top Open cable entry through top also possible
Camera mounting	Removable, 3-piece, fully adjustable system
Max camera/lens size (H x W x D)	76 x 76 x 300 mm (3 x 3 x 11.8 in.)
Window	9.5 mm (0.37 in.) thick scratch-resistant polycarbonate
Material	
top panel	high strength steel
cover	6.3 mm (0.25 in.) cast aluminum
Cover securement	2 security screws

Ordering Information

LTC 9305/00 Indoor Housing **LTC9305/00**

Max. security, wall or ceiling mount, 9.5 mm (0.37 inch) view window

LTC 9305/01 Indoor Housing **LTC9305/01**

Max. security, wall or ceiling mount, 9.5 mm (0.37 inch), view window, with key lock

Americas:
Bosch Security Systems, Inc.
130 Perinton Parkway
Fairport, New York, 14450, USA
Phone: +1 800 289 0096
Fax: +1 585 223 9180
security.sales@us.bosch.com
www.boschsecurity.us

Europe, Middle East, Africa:
Bosch Security Systems B.V.
P.O. Box 80002
5600 JB Eindhoven, The Netherlands
Phone: +31 40 2577 284
Fax: +31 40 2577 330
emea.securitysystems@bosch.com
www.boschsecurity.com

Asia-Pacific:
Robert Bosch (SEA) Pte Ltd, Security Systems
11 Bishan Street 21
Singapore 573943
Phone: +65 6258 5511
Fax: +65 6571 2698
apr.securitysystems@bosch.com
www.boschsecurity.com

Represented by