



# Photobeam 5000

ISC-FPB1-W60QF, ISC-FPB1-W120QF, ISC-FPB1-W200QF



**BOSCH**

**en** Installation and Operation Guide



## Table of contents

|           |  |           |
|-----------|--|-----------|
| <b>1</b>  | <b>Introduction</b>                        | <b>4</b>  |
| 1.1       | About documentation                        | 4         |
| 1.2       | Bosch Security Systems, Inc                | 4         |
| <b>2</b>  | <b>System overview</b>                     | <b>5</b>  |
| 2.1       | Features                                   | 5         |
| 2.2       | Photobeam overview                         | 6         |
| 2.3       | Console overview                           | 7         |
| 2.4       | Transmitter/receiver dimensions            | 8         |
| <b>3</b>  | <b>Installation</b>                        | <b>9</b>  |
| 3.1       | Beam spread                                | 9         |
| 3.2       | Pole mount installation                    | 10        |
| 3.3       | Wall mount installation                    | 12        |
| <b>4</b>  | <b>Wiring</b>                              | <b>13</b> |
| 4.1       | Terminal strip overview                    | 13        |
| 4.2       | Wiring distance                            | 14        |
| 4.3       | Wiring routes                              | 14        |
| <b>5</b>  | <b>Special features</b>                    | <b>16</b> |
| 5.1       | Selectable beams                           | 16        |
| 5.2       | Selectable AND/OR Gate                     | 16        |
| 5.3       | Level LED                                  | 16        |
| 5.4       | EDC (Environmental Discrimination Circuit) | 16        |
| 5.5       | Beam interruption time                     | 17        |
| 5.6       | Beam power control                         | 17        |
| 5.7       | High Density                               | 18        |
| <b>6</b>  | <b>Setup</b>                               | <b>21</b> |
| <b>7</b>  | <b>Installing multiple sets (stacking)</b> | <b>25</b> |
| 7.1       | Group selection                            | 25        |
| 7.2       | Channel selection                          | 27        |
| 7.3       | Synchro wiring                             | 29        |
| 7.4       | Stacking examples                          | 30        |
| 7.4.1     | Single stacking                            | 30        |
| 7.4.2     | Double stack                               | 30        |
| 7.4.3     | Triple stack                               | 31        |
| 7.4.4     | Quadruple stack                            | 32        |
| <b>8</b>  | <b>Optical alignment</b>                   | <b>35</b> |
| 8.1       | Level LED – alignment of the Upper Beam    | 35        |
| 8.2       | Level LED - alignment of the Lower Beam    | 35        |
| 8.3       | Volt meter alignment                       | 36        |
| <b>9</b>  | <b>Operational check</b>                   | <b>38</b> |
| <b>10</b> | <b>Troubleshooting</b>                     | <b>39</b> |
| 10.1      | Additional information                     | 39        |
| <b>11</b> | <b>Certifications</b>                      | <b>40</b> |
| <b>12</b> | <b>Specifications</b>                      | <b>41</b> |

# 1 Introduction

This document contains information that a trained installer needs to install the Photobeam 5000 quad-beam photoelectric detector contained inside the packaging.

## 1.1 About documentation

### Copyright

This document is the intellectual property of Bosch Security Systems, Inc. and is protected by copyright. All rights reserved.

### Trademarks

All hardware and software product names used in this document are likely to be registered trademarks and must be treated accordingly.

## 1.2 Bosch Security Systems, Inc

Use the serial number located on the product label and refer to the Bosch Security Systems, Inc. website at <http://www.boschsecurity.com/datecodes/>.

Manufacturing date information is contained in digit no 1 – 3: DDD.

## 2 System overview

The ISC-FPB1-W60QF, ISC-FPB1-W120QF, and ISC-FPB1-W200QF are quad-beam photoelectric detectors designed for indoor and outdoor applications. Consisting of a separate transmitter and receiver, an alarm is activated when a person passes through the beams. Combination of features and adjustable parameters allow for better catch performance, lower false alarm rates, and reduced effects of environmental disturbances.

### 2.1 Features

For stable operation, the detectors are equipped with the following features:

#### **100% Sensitivity Allowance**

Maintains stable operation even if 99% of beam energy is cut, for example by rain, fog, frost, and so on.

#### **Quad Beam Detection**

Fewer false alarms caused by birds and other small animals because all four beams must be blocked simultaneously to cause an alarm.

#### **Beam Power Control**

Select the appropriate beam intensity relative to the detection range to minimize reflection on nearby walls and cross-talk with other detectors.

#### **Beam Interruption Time Control**

Use to change the beam interruption time to best fit the application.

## 2.2 Photobeam overview

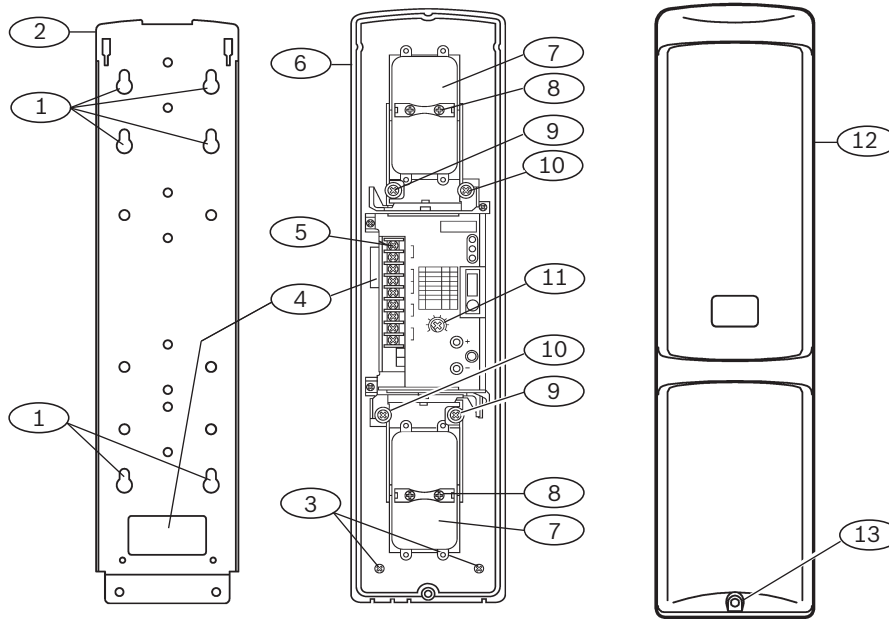

Figure 2.1: Photobeam components overview

| Callout — Description      | Callout — Description      |
|----------------------------|----------------------------|
| 1 — Mounting holes         | 8 — Optical alignment      |
| 2 — Mounting plate         | 9 — Vertical adjustment    |
| 3 — Device securing screws | 10 — Horizontal adjustment |
| 4 — Wire entry             | 11 — Console               |
| 5 — Wiring terminals       | 12 — Cover                 |
| 6 — Detector               | 13 — Cover securing screws |
| 7 — Optical module         |                            |

## 2.3 Console overview

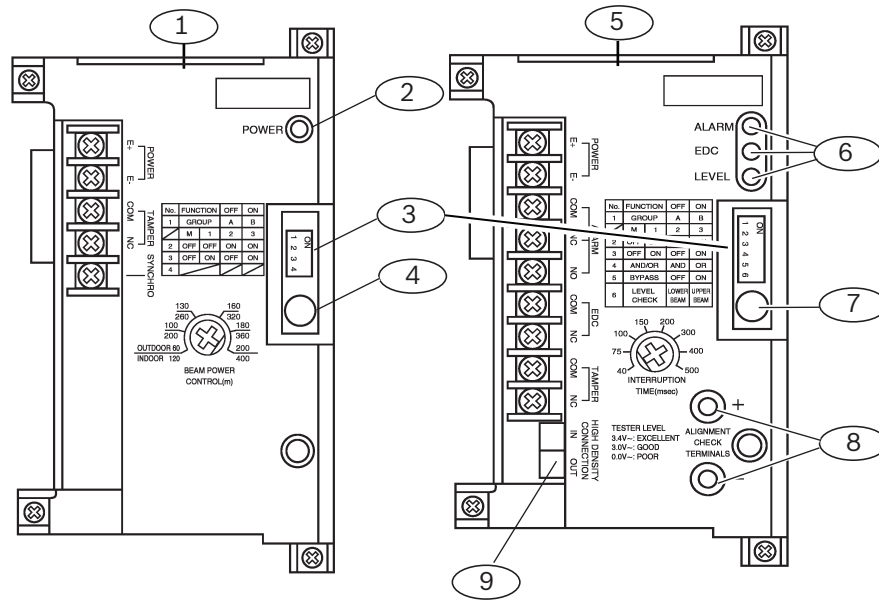

Figure 2.2: Console components overview

| Callout — Description   | Callout — Description         |
|-------------------------|-------------------------------|
| 1 — Transmitter console | 6 — Status indicators         |
| 2 — Power indicator     | 7 — Sensitivity control       |
| 3 — Function switches   | 8 — ALIGNMENT CHECK TERMINALS |
| 4 — BEAM POWER CONTROL  | 9 — HIGH DENSITY terminals    |
| 5 — Receiver console    |                               |

## 2.4 Transmitter/receiver dimensions

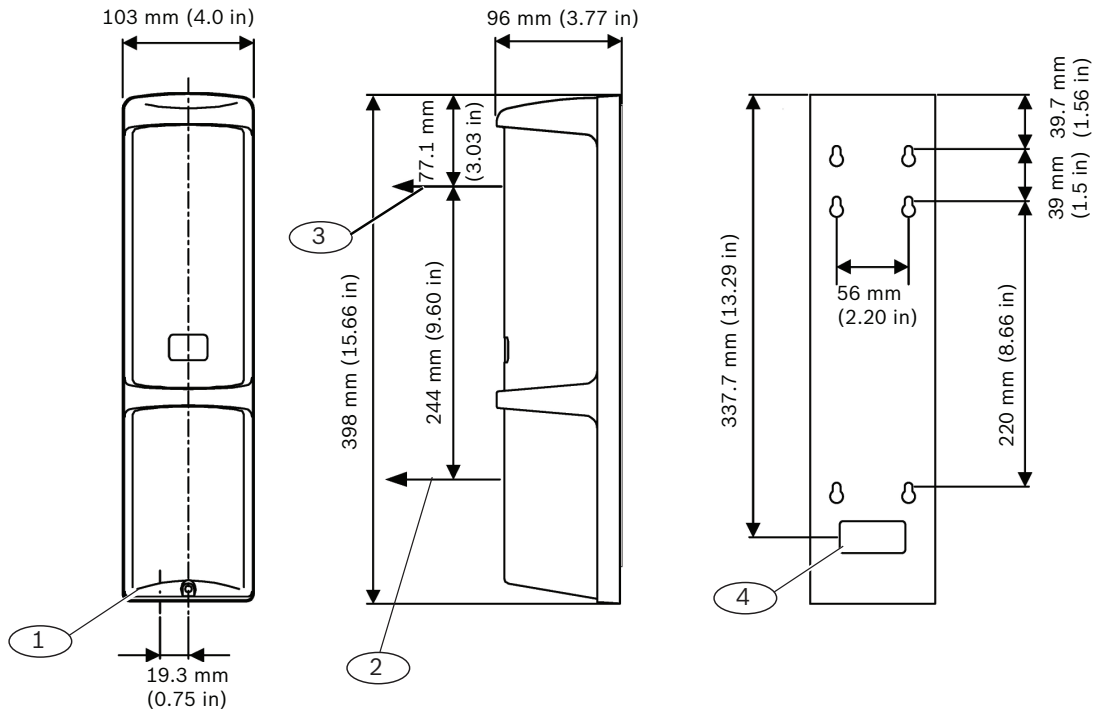

Figure 2.3: Transmitter/receiver dimensions

| Callout – Description        | Callout – Description        |
|------------------------------|------------------------------|
| 1 – Knockout wire entrance   | 3 – Center of the Upper Beam |
| 2 – Center of the Lower Beam | 4 – Wire entrance            |



### 3 Installation

Prior to installing the devices, please review the installation considerations below:

- Install in an area that is clear of objects
- Install the transmitter/receiver within the maximum protection range of the model
- Do not install:
  - Receivers into intense sources of light (for example, rising and setting sun)
  - On movable surfaces subject to vibrations
  - Detectors where immersion to water, corrosive liquids, or exposure to high levels of dust can occur
  - Detectors in close proximity to strong electromagnetic noises
- Do not use detectors with other photobeam detectors or receivers
- Do not disassemble or modify this detector
- Do not install while the power is on
- Avoid extreme temperature and humidity ranges as defined in the products specifications
- Avoid installing detectors near magnets and/or magnetized materials
- Avoid beam interference between other units when multiple units are installed
- Use the selectable beam's feature when stacking detectors

#### 3.1 Beam spread

The beam spread angle is  $\pm 0.7^\circ$  from the transmitter to the receiver. Refer to the diagram and table below to determine the installation conditions.

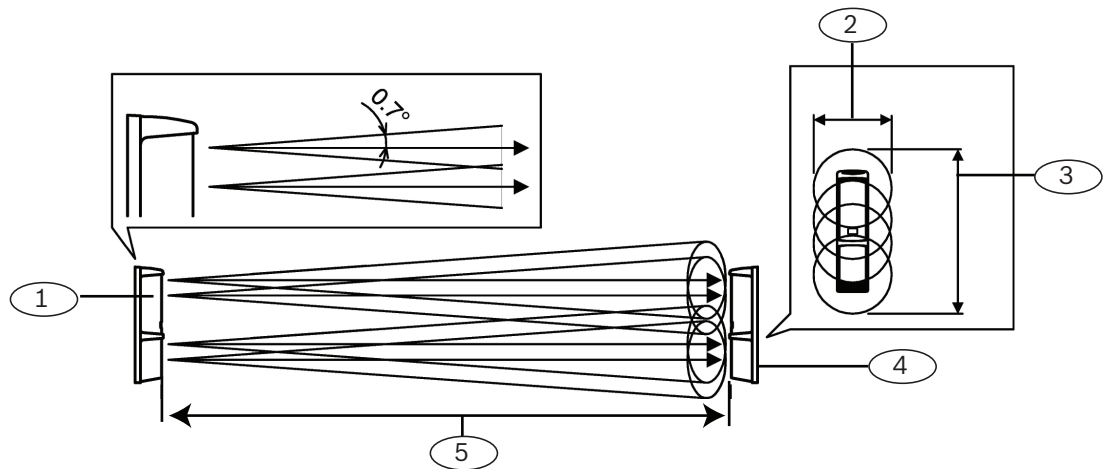

Figure 3.1: Beam distance and spread

| Callout – Description     | Callout – Description |
|---------------------------|-----------------------|
| 1 – Transmitter           | 4 – Receiver          |
| 2 – Horizontal spread (B) | 5 – Distance (A)      |
| 3 – Vertical spread (C)   |                       |

| Distance, horizontal and vertical spread values: (A) / (B) / (C) |                            |
|--|----------------------------|
| Metric   | Imperial unit              |
| 20 m / 0.5 m / 0.8 m   | 65 ft / 1.6 ft / 2.6 ft    |
| 40 m / 1.0 m / 1.3 m   | 13.1 ft / 3.2 ft / 4.2 ft  |
| 60 m / 1.5m / 1.8 m  | 196 ft / 4.9 ft / 5.9 ft   |
| 80 m / 2.0 m / 2.2 m   | 262 ft / 6.5 ft / 7.2 ft   |
| 100 m / 2.5 m / 2.7 m  | 328 ft / 8.2 ft / 8.8 ft   |
| 120 m / 3.0 m / 3.2 m  | 393 ft / 9.8 ft / 10.4 ft  |
| 140 m / 3.5 m / 3.7 m  | 459 ft / 11.4 ft / 12.1 ft |
| 160 m / 4.0 m / 4.2 m  | 524 ft / 13.1 ft / 13.7 ft |
| 180 m / 4.5 m / 4.7 m  | 590 ft / 14.7 ft / 15.4 ft |
| 200 m / 5.0 m / 5.2 m  | 656 ft / 16.4 ft / 17.0 ft |

### 3.2 Pole mount installation

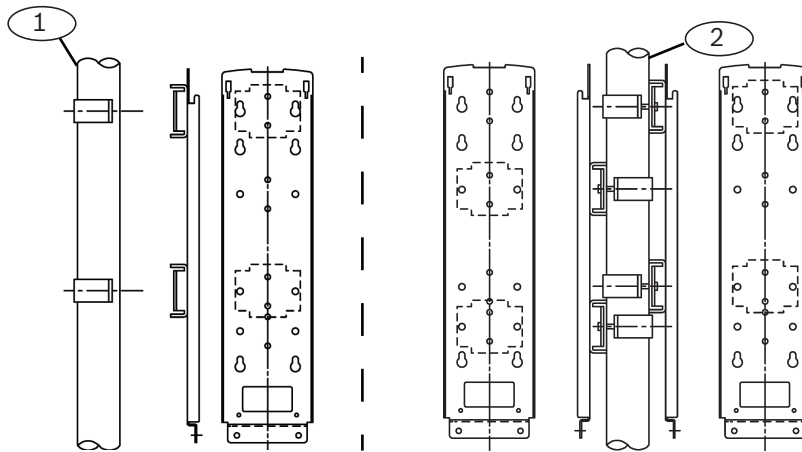
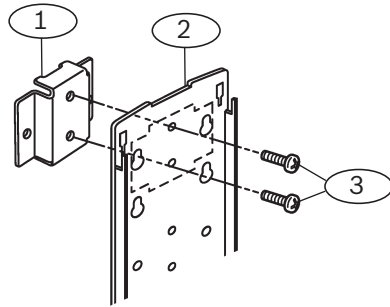

Figure 3.2: Pole mounting view

| Callout – Description                        | Callout – Description          |
|--|--------------------------------|
| 1 — Diameter 38.0 – 42.7 mm (1.50 – 1.68 in) | 2 — Back-to-back pole mounting |

Attaching the mounting bracket:

1. Choose an appropriate mounting location for the devices. Install the mounting poles with a clear line-of-sight between the transmitter and receiver.
2. Loosen the transmitter’s cover mounting screw and remove the cover.
3. Loosen the two base mounting screws and remove the mounting plate by sliding it down.
4. Attach the mounting hardware to the mounting plate using the clamping screws. Refer to the figure below.

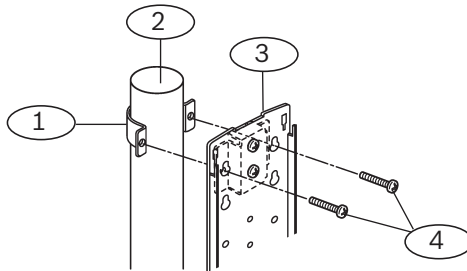

**Figure 3.3: Attaching the mounting bracket**

| Callout – Description       |
|-----------------------------|
| 1 – Mounting hardware       |
| 2 – Mounting plate          |
| 3 – Clamping screws (short) |

Attaching the mounting plate:

1. Attach the mounting plate to the poles using the U-clamps.
2. Use the U-clamps and clamping screws to attach the mounting plate firmly to the poles.



**Figure 3.4: Attaching the U-clamp**

| Callout – Description      |
|----------------------------|
| 1 – U-clamp                |
| 2 – Mounting pole          |
| 3 – Mounting plate         |
| 4 – Clamping screws (long) |

Wire routing:

1. Route the wire through the wire entry location of the mounting plate, leave enough wire to reach the terminal strip.
2. Route the wire through the transmitter’s wire entry.
3. Slide the transmitter onto the mounting plate, and secure using the included screws.
4. Repeat this procedure for the receiver, verify line-of-sight with the transmitter.
5. Wire to the terminal strips. Refer to Wiring for wiring procedures.



**Caution!**

Ensure that the pole mount installation is secure and stable. Failure to do so may result in personal injury, or damage the device.

### 3.3 Wall mount installation

Installing the transmitter and receiver:

1. Remove the cover and mounting plate from the transmitter.
2. Route the wire through the mounting plate wire entry if the wire is routed through a wall opening. If the wire is routed on the wall surface, knock-out the thin wall wire hole at the bottom of the transmitter and cover. Route the wire through the opening after the mounting plate is secured onto the wall.
3. Secure the mounting plate to the wall surface.
4. Route the wire through the detector wire entry location.
5. Secure the transmitter to the mounting plate.
6. Wire to the terminal strips. Refer to Wiring for wiring procedures.
7. Repeat this procedure for mounting the receiver.

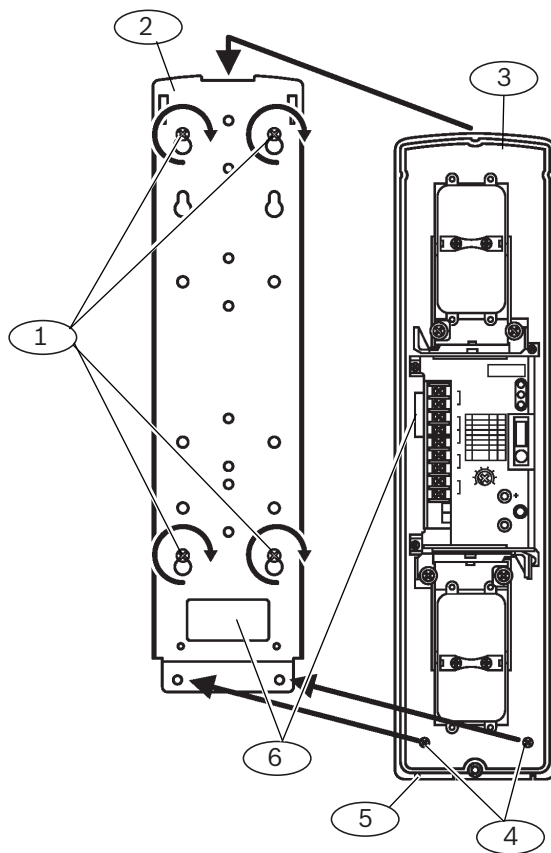

**Figure 3.5: Wall mount installation**

| Callout — Description | Callout — Description      |
|-----------------------|----------------------------|
| 1 — Mounting screws   | 4 — Device securing screws |
| 2 — Mounting plate    | 5 — Knockout               |
| 3 — Detector          | 6 — Wire entry             |

# 4 Wiring

Refer to *Terminal strip* below for transmitter/receiver terminal locations. Use duct pipes for outdoor wiring. Do not use aerial wiring.



**Caution!**

Complete all electrical connections and inspect them prior to applying power.



**Notice!**

Tamper and EDC terminals should be connected to a 24-hour supervisory loop



**Notice!**

Power is to be provided by a UL Listed burglar alarm power supply or burglar alarm control panel. In case of power failure, the power supply or control unit shall have a minimum of 4 hours of standby power.



**Notice!**

All wiring is to be in accordance with the National Electric Code, ANSI/NFPA 70.



**Notice!**

This system should be tested at least once a week to ensure proper function.

## 4.1 Terminal strip overview

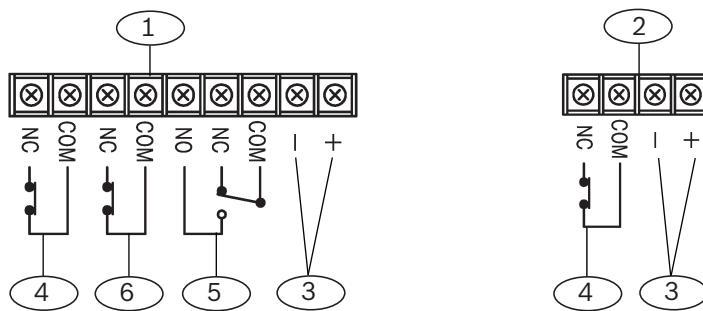

Figure 4.1: Terminal strip component overview

| Callout – Description     | Callout – Description |
|---------------------------|-----------------------|
| 1 – Receiver              | 4 – Tamper            |
| 2 – Transmitter           | 5 – Alarm output      |
| 3 – Power (non-polarized) | 6 – EDC output        |

## 4.2 Wiring distance

Refer to the table to determine the minimum wire gauge for a single sensor system (one transmitter and one receiver). The distances specified are between the power source and the last (farthest) unit on the single wire run. For multiple detector configurations, divide the wire distance in the table by the number of systems in the configuration (1 system = 1 transmitter and 1 receiver).

| Wire Gauge |      | Maximum wiring distance |                      |                    |                      |                    |                      |
|------------|------|-------------------------|----------------------|--------------------|----------------------|--------------------|----------------------|
|            |      | ISC-FPB1-W60QF          |                      | ISC-FPB1-W120QF    |                      | ISC-FPB1-W200QF    |                      |
| AWG        | Ø mm | 12V                     | 24V                  | 12V                | 24V                  | 12V                | 24V                  |
| 22         | 0.65 | 90 m<br>(295 ft)        | 820 m<br>(2690 ft)   | 80 m<br>(262 ft)   | 790 m<br>(2591 ft)   | 80 m<br>(262 ft)   | 770 m<br>(2526 ft)   |
| 19         | 0.90 | 170 m<br>(557 ft)       | 1600 m<br>(5249 ft)  | 170 m<br>(557 ft)  | 1550 m<br>(5085 ft)  | 160 m<br>(524 ft)  | 1500 m<br>(4921 ft)  |
| 17         | 1.14 | 320 m<br>(1049 ft)      | 2930 m<br>(9612 ft)  | 310 m<br>(1017 ft) | 2830 m<br>(9284 ft)  | 300 m<br>(984 ft)  | 2740 m<br>(8989 ft)  |
| 14         | 1.62 | 570 m<br>(1870 ft)      | 5150 m<br>(18896 ft) | 550 m<br>(1804 ft) | 4980 m<br>(16338 ft) | 530 m<br>(1738 ft) | 4820 m<br>(15813 ft) |

## 4.3 Wiring routes

Refer to the graphics below for wiring routes examples. The illustrations depict both one, and two sets of detector systems on a single wire run.

The graphics below show simple examples of wiring concepts, depicting how to power the transmitter and receiver pairs, and how to combine alarm outputs. Local regulatory requirements and technical parameters specific to a connected control panel determine the exact details of the wiring. Review local regulations and the connected control panels technical documentation before planning wire routes and connections. Selecting the proper wire routes and gauges depend on the number of devices, overall distance, and voltage drop parameters for each individual device.

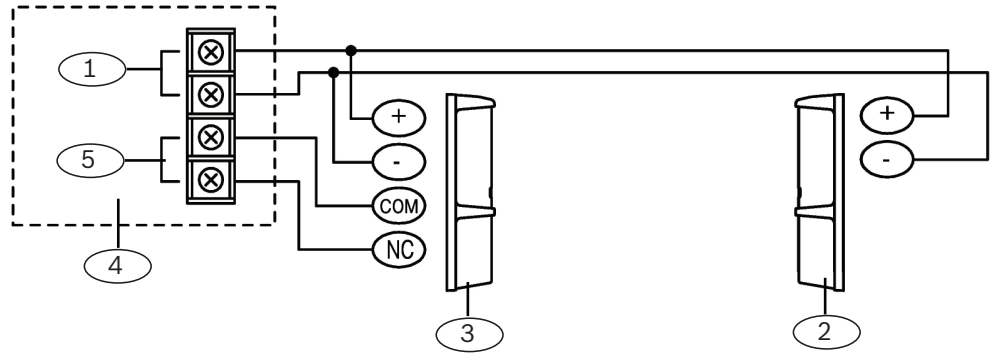

Figure 4.2: Wiring for one set on the run

| Callout – Description | Callout – Description   |
|-----------------------|---|
| 1 – Power output      | 4 – Control panel   |
| 2 – Transmitter       | 5 – Alarm input. The COM and NC terminals on the unit are the outputs, they connect to a control panel input. |
| 3 – Receiver          |   |

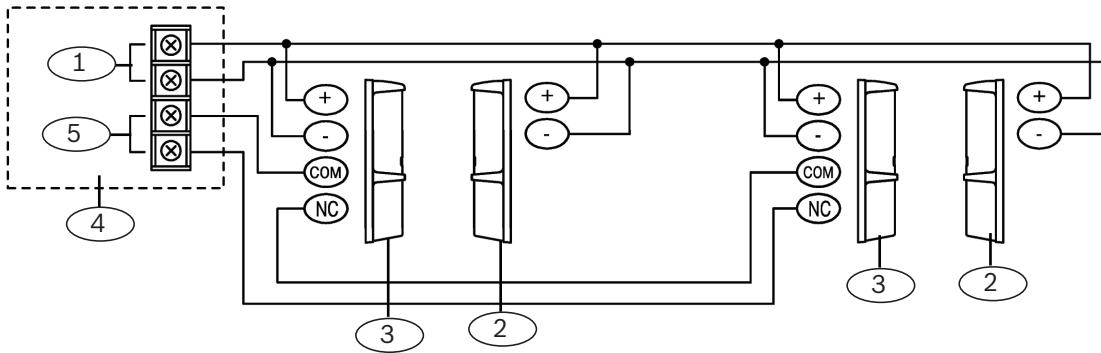

Figure 4.3: Wiring for two sets on a single run

| Callout – Description | Callout – Description   |
|-----------------------|---|
| 1 – Power output      | 4 – Control panel   |
| 2 – Transmitter       | 5 – Alarm input. The COM and NC terminals on the unit are the outputs, they connect to a control panel input. |
| 3 – Receiver          |   |



**Notice!**

The BH12T heater is an optional device. Refer to the BH12T installation instructions (P/N: W. 97.2195) for more information.

## 5 Special features

Refer to the following for sensitivity adjustments.

### 5.1 Selectable beams

Crosstalk occurs when multiple beams are stacked or when used in long distances which might cause a missed alarm (no catch). The devices are equipped with 8 different selectable beam channels (2 Groups and 4 Channels) to prevent crosstalking. The selectable beam channel feature allows the receiver to ignore the beams received from other transmitters when the installation requires multiple devices to be placed in an area where a receiver is in the beam spread of multiple transmitters. For more information on crosstalking, refer to *Installing multiple sets (stacking)*, page 25.

### 5.2 Selectable AND/OR Gate

Environmental conditions might require higher false alarm tolerance against smaller objects passing through the detector's line of sight. To do this, set the AND/OR gate option to AND gate mode that only causes an alarm condition when all four infrared beams are interrupted simultaneously.

High Security applications might require the detection of smaller objects passing through the detector's line of sight. To do this, set the AND/OR gate option to OR gate mode that causes an alarm condition when either the upper two beams or the lower two beams are interrupted.

Use the selectable dip switches to choose the AND/OR GATE option on the receiver.

### 5.3 Level LED

The Level LED shows the beams energy level received during alignment. As more beam energy is received, the illumination time shortens as follows: ON => OFF once => OFF twice => OFF three times => Flashing => ON three times => ON twice => ON once => OFF.

When the LED turns off, the alignment is complete.

Refer to Console overview for Status Indicator locations (callout #6).

### 5.4 EDC (Environmental Discrimination Circuit)

The EDC generates a signal when the beam power level is significantly reduced due to environmental conditions such as fog or rain. Two Bypass switch features are used at the receiver, Bypass Switch Off, and Bypass Switch On.

The inability to operate for more than 3 seconds due to environmental conditions is defined as a "Poor Environmental Condition."

| Switch | Condition  | Description  |
|--------|--|--|
| Off    | When poor environmental conditions present:                  | The EDC LED turns on and the EDC output activates. Alarm signal is generated upon further loss of the beam energy. |
|        | When either optical module is blocked for 3 or more seconds: | The EDC LED turns on and the EDC output activates. No alarm is generated.  |



| Switch | Condition  | Description  |
|--------|--|--|
|        | When both optical modules are blocked for 3 or more seconds: | The alarm LED turns on and an alarm signal is generated. EDC LED turns on and EDC output activates.  |
| On     | When poor environmental conditions present:                  | The EDC LED turns on and the EDC output activates. Alarm LED turns on after further loss of beam energy but does not generate an alarm signal.   |
|        | When either optical module is blocked for 3 or more seconds: | The EDC LED turns on and provides a EDC signal. Alarm LED turns on without generating an alarm signal if another optical module is blocked.  |
|        | When both optical modules are blocked for 3 or more seconds: | The alarm LED turns on and alarm signal is generated. EDC LED does not turn on and does not activate the EDC output. It is recommended to connect the EDC output to a trouble input point at the control panel. It is recommended to check the system any time the EDC relay has been activated. |



**Notice!**

Connect the EDC to an input circuit and check the system any time the EDC relay is activated.



**Notice!**

The EDC feature was not investigated by Underwriters Laboratories (UL).

## 5.5 Beam interruption time

The beam interruption time defines the amount of time an intruder must spend in the beam path before an alarm is generated. For instance, if the interruption time is set at 100 ms, the detector only generates an alarm if the beams are blocked for more than 100 ms.



**Notice!**

For UL applications, do not set the interrupt time above 75 ms.

## 5.6 Beam power control

The receiver is at optimal detection level when the transmitter's Beam Power Control setting matches the installation range. When the Beam Power is not reduced to match shorter distance, reflection off of nearby surfaces may occur and may cause a missed alarm (no

catch). Beam Power level set to greater than the installation range may also cause cross-talk with other devices in the line of sight of the transmitter. The Beam Power Control adjusts the amount of beam energy for optimal range.

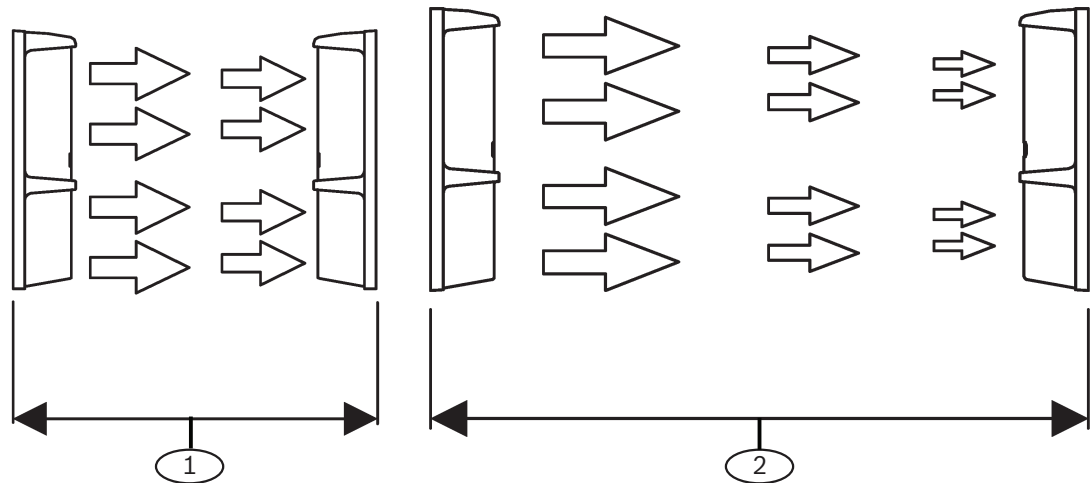

Figure 5.1: Detection range

| Callout – Description       |
|-----------------------------|
| 1 – Short range             |
| 2 – Maximum detection range |

## 5.7

### High Density

Multiple devices may be stacked on top of each other in high security installations which also require higher false alarm tolerance against smaller objects. You can use the high density alarm feature to detect larger objects that only partly interrupt the beams of individual devices.

This feature allows an alarm condition to be generated when beam pairs are interrupted on adjacent devices, but not on all four beams within one device.

Connect the first receiver's OUT terminal to the second receiver's IN terminal to form an AND gate between the two units when stacking units on top of each other. Follow the same procedure to link up to 8 devices when stacking more than two devices.

- Only the alarm function is linked between the devices. The EDC and tamper connections are not affected by this feature.
- All connected devices must be set to AND gate mode when using the High Density.
- Use only those connectors which are shipped with the product.
- The High Density link cable between devices can not exceed 2 m (6.5 ft) length.
- Always connect an OUT terminal with another device's IN terminal.
- Do not link OUT terminals of different devices with each other.
- Do not link IN terminals of different devices with each other.
- Do not connect IN and OUT terminals in parallel with each other.

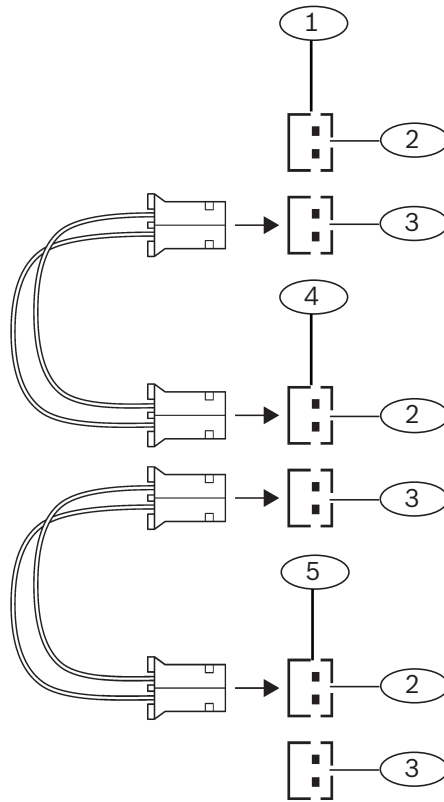

**Figure 5.2: High density synchro wiring**

| Callout – Description        |
|------------------------------|
| 1 – Receiver 1               |
| 2 – Receiver IN connections  |
| 3 – Receiver OUT connections |
| 4 – Receiver 2               |
| 5 – Receiver 3               |

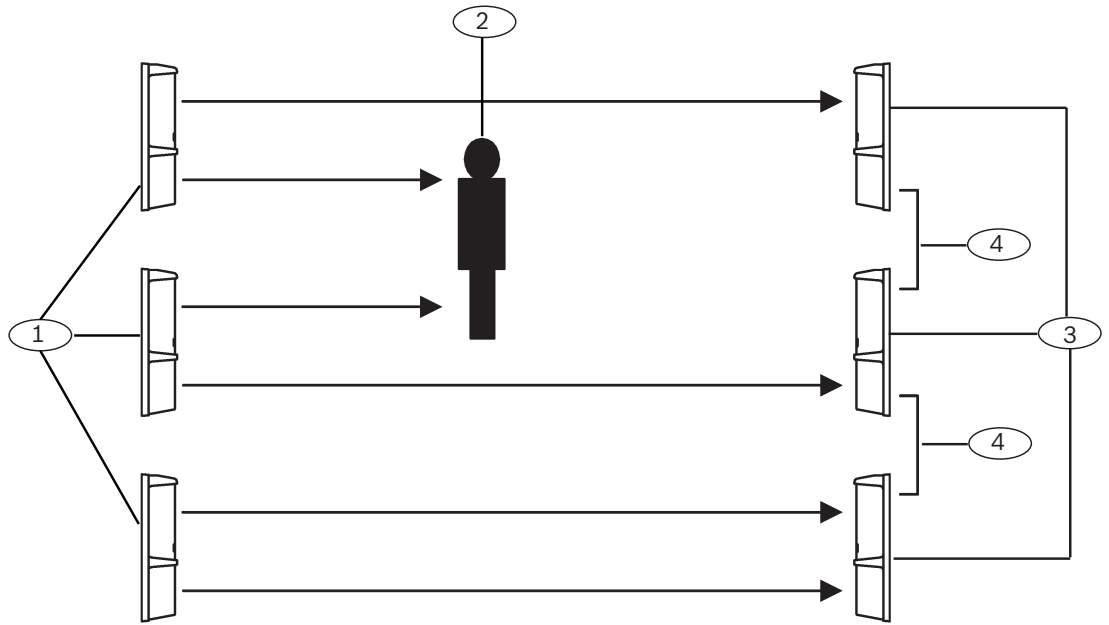

**Figure 5.3: High density configuration**

| Callout – Description                                    |
|--|
| 1 – Transmitters (1, 2, and 3)                           |
| 2 – Intruder (breaking the beams of transmitter 1 and 2) |
| 3 – Receivers (1, 2, and 3)                              |
| 4 – OUT/IN connections                                   |

# 6 Setup

Turn the Bypass switch on to activate the bypass feature.

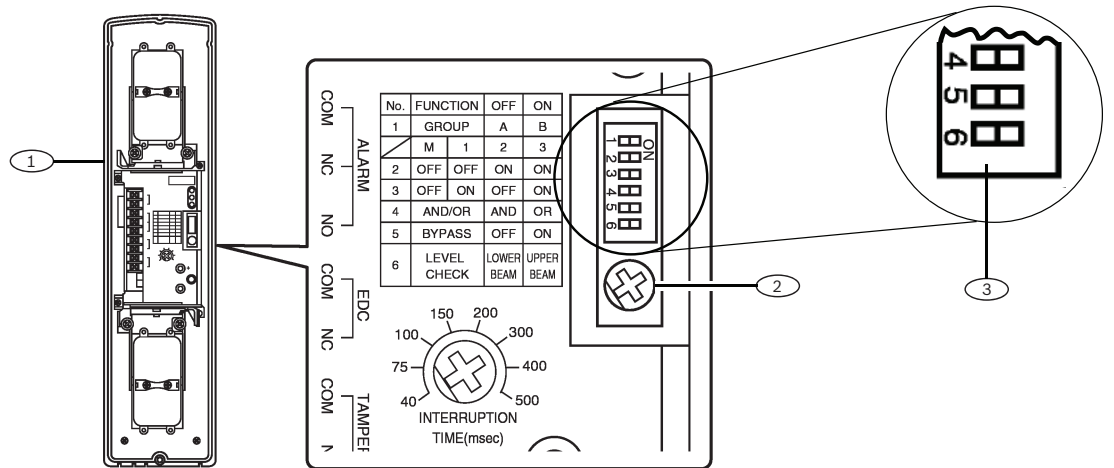

Figure 6.1: Receiver Bypass switch

| Callout – Description  |
|--|
| 1 — Receiver   |
| 2 — Switches (AND/OR GATE switch 4, BYPASS switch 5, and LEVEL CHECK switch 6) |
| 3 — Beam interruption time sensitivity volume                                  |

**AND/OR Gate (on the receiver)**

Set the dip switch 4 on the receiver to:  
 ON: OR GATE  
 OFF: AND GATE (original position)

**BYPASS (on the receiver)**

Set the dip switch 5 on the receiver to:  
 ON: BYPASS activated  
 OFF: BYPASS not activated (original position)

**LEVEL CHECK (on the receiver)**

Set the dip switch 6 on the receiver to:  
 ON: Perform optical alignment of the upper beam  
 OFF: Perform optical alignment of the lower beam (default position)

**Interruption time**

Turn the sensitivity control on the receiver clockwise to reduce sensitivity and counterclockwise to increase sensitivity.

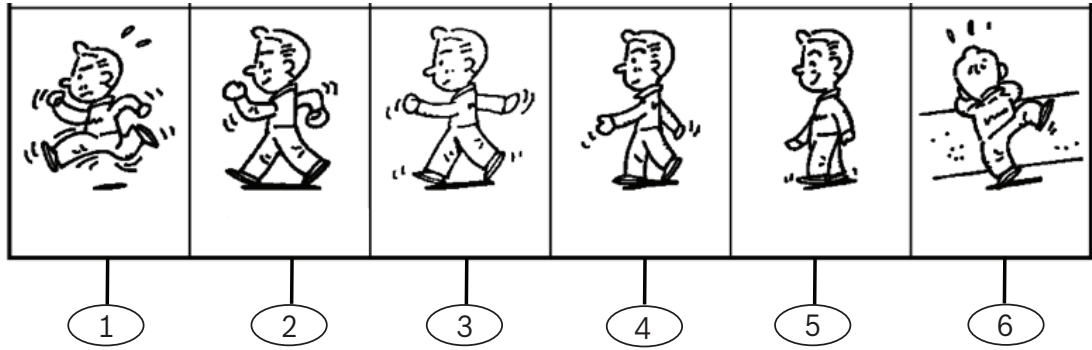

**Figure 6.2: Interruption time**

| Callout – Description   | Callout – Description     |
|-------------------------|---------------------------|
| 1 – 40 ms running       | 4 – 300 ms normal walking |
| 2 – 100 ms jogging      | 5 – 400 ms slow walking   |
| 3 – 200 ms fast walking | 6 – 500 ms slow moving    |

**Beam power control**

Turn the Beam Power Control on the transmitter clockwise to increase beam power. Turn counter-clockwise to decrease beam power. Refer to table below.

| Model           | Volume setting of beam power control (outdoors) |                   |                          |                           |                           |                           |                           |
|-----------------|---|-------------------|--------------------------|---------------------------|---------------------------|---------------------------|---------------------------|
| ISC-FPB1-W60QF  | volume  | 20                | 30                       | 40                        | 50                        | 55                        | 60                        |
|                 | range   | <20 m<br>(65 ft)  | 20-30 m<br>(65-98 ft)    | 30-40 m<br>(98-131 ft)    | 40-50 m<br>(131-164 ft)   | 50-55 m<br>(164-180 ft)   | 55-60 m<br>(180-196 ft)   |
| ISC-FPB1-W120QF | volume  | 40                | 60                       | 80                        | 100                       | 110                       | 120                       |
|                 | range   | <40 m<br>(131 ft) | 40-60 m<br>(131-196 ft)  | 60-80 m<br>(196-262 ft)   | 80-100 m<br>(262-328 ft)  | 100-110 m<br>(328-360 ft) | 110-120 m<br>(360-393 ft) |
| ISC-FPB1-W200QF | volume  | 60                | 100                      | 130                       | 160                       | 180                       | 200                       |
|                 | range   | <60 m<br>(131 ft) | 60-100 m<br>(131-328 ft) | 100-130 m<br>(328-426 ft) | 130-160 m<br>(426-524 ft) | 160-180 m<br>(524-590 ft) | 180-200 m<br>(590-656 ft) |

| Model           | Volume setting of beam power control (indoors) |                    |                           |                           |                            |                             |                             |
|-----------------|--|--------------------|---------------------------|---------------------------|----------------------------|-----------------------------|-----------------------------|
| ISC-FPB1-W60QF  | volume   | 40                 | 60                        | 80                        | 100                        | 110                         | 120                         |
|                 | range  | <40 m<br>(131 ft)  | 40-60 m<br>(131-196 ft)   | 60-80 m<br>(196-262 ft)   | 80-100 m<br>(262-328 ft)   | 100-110 m<br>(328-360 ft)   | 110-120 m<br>(360-393 ft)   |
| ISC-FPB1-W120QF | volume   | 80                 | 120                       | 160                       | 200                        | 220                         | 240                         |
|                 | range  | <80 m<br>(262 ft)  | 80-120 m<br>(262-393 ft)  | 120-160 m<br>(393-524 ft) | 160-200 m<br>(524-656 ft)  | 200-220 m<br>(656-721 ft)   | 220-240 m<br>(721-787 ft)   |
| ISC-FPB1-W200QF | volume   | 120                | 200                       | 260                       | 320                        | 360                         | 400                         |
|                 | range  | <120 m<br>(393 ft) | 120-200 m<br>(393-656 ft) | 200-260 m<br>(656-853 ft) | 260-320 m<br>(853-1049 ft) | 320-360 m<br>(1049-1181 ft) | 360-400 m<br>(1181-1312 ft) |

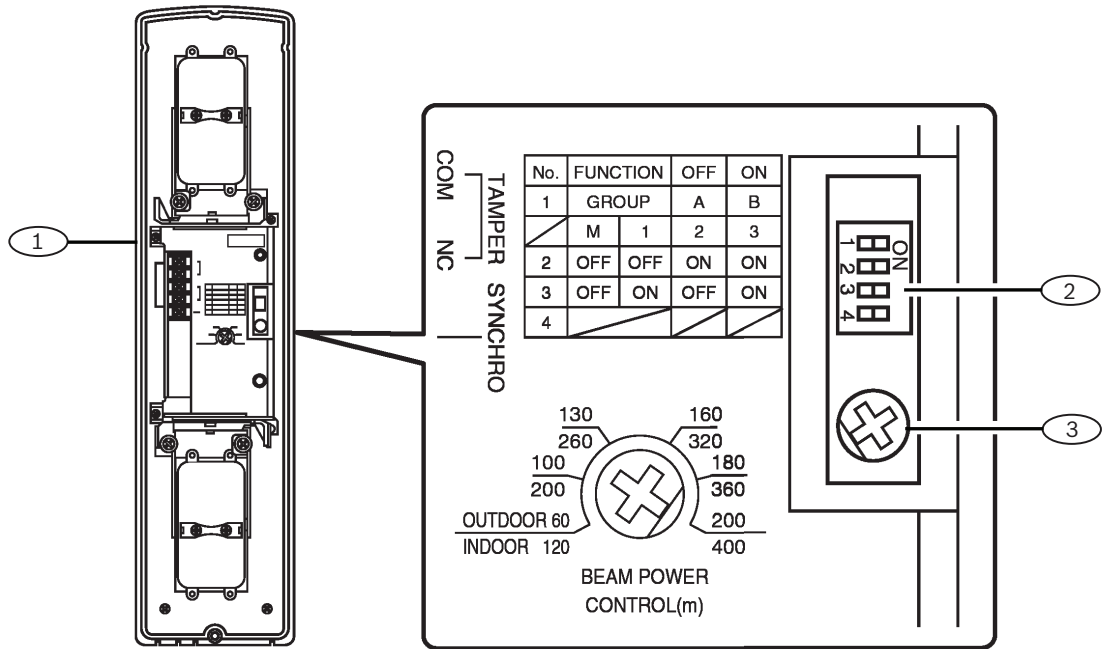

Figure 6.3: Beam switch

| Callout – Description | Callout – Description  |
|-----------------------|------------------------|
| 1 – Transmitter       | 3 – Beam power control |
| 2 – Beam switch       |                        |



## 7 Installing multiple sets (stacking)

This section describes the positioning of photobeam sets as well as several examples of how they are stacked. Depending on your installation environment, you can install a single or up to a four-level stack for maximum coverage.

The term "set" describes one transmitter and one receiver pairing. The term "crosstalk" is a type of interference.

### Interference

Photobeam interference or "crosstalk" in a single or multiple stack occurs when more than one transmitter signal is received by one receiver and interferes with normal operation.

Each photobeam set can be programmed to a specific group; Group A or Group B in order to reduce crosstalk interference in a single stack environment. In a multi-stack environment, you can program each photobeam set to a specific group and channel.

### Installation recommendations

When installing multiple sets, it is recommended to install them in a similar fashion as depicted in the illustration below, whereby each transmitter (T) is emitting its beam in an opposing direction from the other transmitter, and being received by its corresponding receiver (R).



### Notice!

Photobeam group/channel dip switch selections and synchro wires are not required when installing a photobeam set (one transmitter and one receiver).

### 7.1 Group selection

The Group option allows you to install multiple sets of photobeams, covering a larger perimeter area, while reducing the chances of crosstalk and interference. The options to choose from include Group A or Group B.

Group selection is accomplished through setting Dip Switch 1 to either the ON, or OFF position on both the transmitter and receiver. Set each transmitter/receiver set to the same group for proper functionality. Refer to the graphic below for dip switch locations on both the transmitter and receiver.

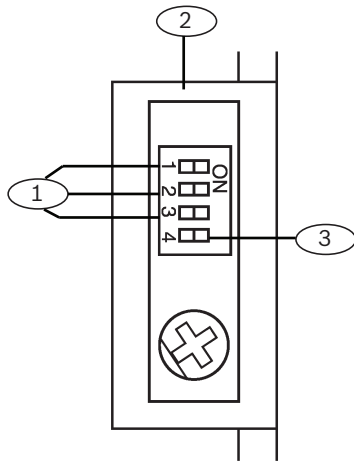

**Figure 7.1: Transmitter**

| Callout – Description  |
|--|
| 1 – Switches 1, 2, and 3 (Switch 1 determines Group A or Group B selection. Switches 2 and 3 determine channel assignments.) |
| 2 – Transmitter  |
| 3 – Switch 4 (not used)  |

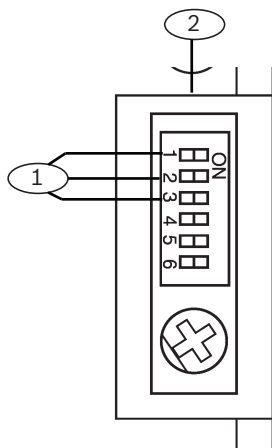

**Figure 7.2: Receiver**

| Callout – Description  |
|--|
| 1 – Switches 1, 2, and 3 (Switch 1 determines Group A or Group B selection. Switches 2 and 3 determine channel assignments.) |
| 2 – Receiver   |

**Group selection**

Use the following table below to select the desired group setting.

|       |              |
|-------|--------------|
| Group | Switch No. 1 |
| A     | OFF          |
| B     | ON           |

**Table 7.1: Group selection**

**Application**

The use of the beam Group A/Group B selection is best illustrated below.

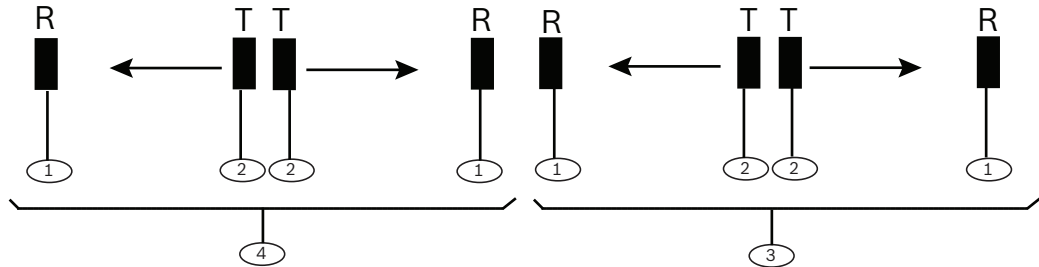

**Figure 7.3: Beam group selection**

| Callout – Description                                |
|--|
| 1 – Receivers  |
| 2 – Transmitters                                     |
| 3 – Transmitter/receiver sets programmed for Group B |
| 4 – Transmitter/receiver sets programmed for Group A |

Transmitters emitting beams that are assigned to Group A do not interfere with receivers collecting beam signals from transmitters assigned to Group B. The same holds true for transmitters assigned to Group B not interfering with receivers assigned to Group A. The frequencies emitted from Group A are different than the frequencies emitted from Group B, and therefore do not interfere with one another.

## 7.2 Channel selection

Selecting different channels (frequencies) on the transmitter/receiver sets allows you to further expand your photobeam stacking capabilities and coverage. Multi-stack configurations allow you to increase the area of protection with respect to height. This occurs by assigning each stack (row) a specific channel setting as you build multiple photobeam stacks, one above the other. Beam crosstalking and interference between stacks are eliminated as each stack (row) has its own unique channel.

When installing multiple stacks, the initial stack must be assigned as the Master (notated as “M” in the corresponding tables located on each transmitter and receiver). Each additional stack is assigned a separate channel number (1 to 3). You cannot have a multiple stack configuration without assigning one stack as the Master. Refer to the transmitter and receiver illustrations in the previous section for channel programming and dip switch locations (Channels 1 to 3).

In a multi-stack configuration, it is possible to have a stack or a row of four-beam sets assigned to Group A, with each stack also being assigned to a specific channel, channel M (Master), 1, 2, or 3. A similar configuration is possible with a multiple stack configuration assigned to Group B.

Channels 1, 2, and 3 emit beams only when Channel M (Master) is active. Channels 1, 2 and/or 3 emit beams only when connected to the Channel M stack through the use of a “synchro” wire. Refer to *Synchro wiring*, page 29 for more details.

**Group A and Group B channel selections**

|         |                    |
|---------|--------------------|
| Group A | Channel M (Master) |
|         | Channel 1          |
|         | Channel 2          |
|         | Channel 3          |
| Group B | Channel M (Master) |
|         | Channel 1          |
|         | Channel 2          |
|         | Channel 3          |



**Notice!**

In a multi-stack configuration, one row must be assigned as the Master (M) with each corresponding stack assigned a different channel (1 to 3) and attached by synchro wiring.

Refer to the following tables for transmitter/receiver channel programming.

**Group switch settings**

| Switch | Function | OFF | ON |
|--------|----------|-----|----|
| 1      | GROUP    | A   | B  |

**Channel switch settings**

| Switch | Function |     |     |    |
|--------|----------|-----|-----|----|
|        | M        | 1   | 2   | 3  |
| 2      | OFF      | OFF | ON  | ON |
| 3      | OFF      | ON  | OFF | ON |

**Extra features switch settings**

| Switch | FUNCTION    | OFF        | ON         |
|--------|-------------|------------|------------|
| 4      | AND/OR Gate | AND        | OR         |
| 5      | BYPASS      | OFF        | ON         |
| 6      | LEVEL CHECK | LOWER BEAM | UPPER BEAM |

### 7.3 Synchro wiring

Use synchronized (abbreviated “synchro”) wires when installing two or more sets in the same group by using the SYNCHRO terminal on each transmitter. Synchro wires allow each transmitter’s frequency to be synchronized at the same starting point to eliminate false emissions to the receiver. Synchro wires are not required between the receivers. Refer to the graphic below depicting a synchro wiring connection between two photobeam stacks (a maximum of 4 stacks are supported).

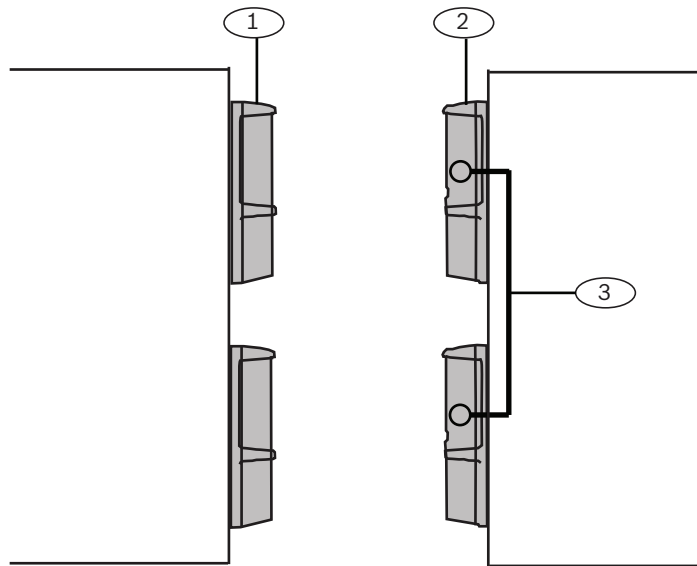

Figure 7.4: Synchro wiring

| Callout – Description                                    |
|--|
| 1 – Receiver   |
| 2 – Transmitter (synchro terminals on transmitters only) |
| 3 – Synchro wire   |

The synchro wire should be more than 0.65 mm (22 AWG) and run no longer than 20 m (66 ft) in length. Synchro wiring should only be wired to the same group (Group A to Group A, or Group B to Group B), and the connected devices must use a common power supply.



**Notice!**

The system does not activate when synchro wires are connected improperly. The POWER LED flashes when the required wires are not connected correctly.



**Caution!**

When the POWER LED flashes, shut off the power and reconnect the wires correctly.

## 7.4 Stacking examples

Photobeam sets combined together form a stack. A stack is similar to a row in that you can install up to four rows (stacks) of photobeams when securing a perimeter, or area. In the following sections, four stacking examples are shown with brief descriptions as to why you might install a stack configuration.

### 7.4.1 Single stacking

Refer to the following graphic below for a single stack example.

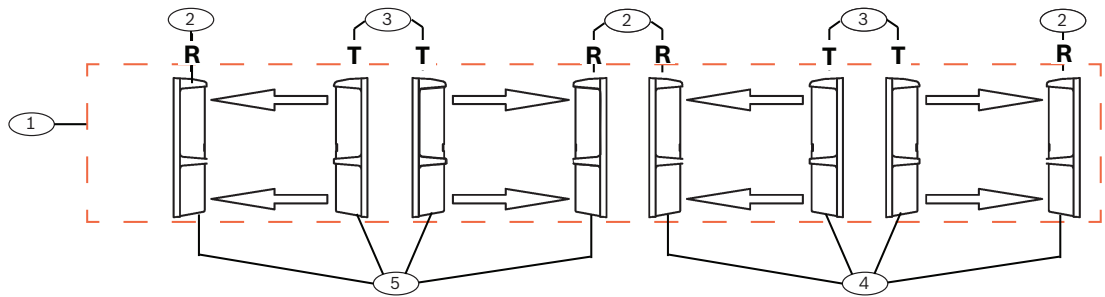

Figure 7.5: Stacking in long distance (single stack)

| Callout – Description                  |
|--|
| 1 – Single stack assigned to Channel M |
| 2 – Receiver                           |
| 3 – Transmitter                        |
| 4 – Group B transmitter/receiver pairs |
| 5 – Group A transmitter/receiver pairs |

#### Application

Using a single stack configuration provides a basic level of detection when you want to secure a longer distance perimeter area like a fence.

In single stack configurations:

- Select all devices for Channel M.
- Set photobeam sets depicted in the above illustration, to Group B (callout 4) to avoid crosstalk with sets in Group A (callout 5).
- Synchro wires are not required.

### 7.4.2 Double stack

Refer to the following graphic below for a double stack example.

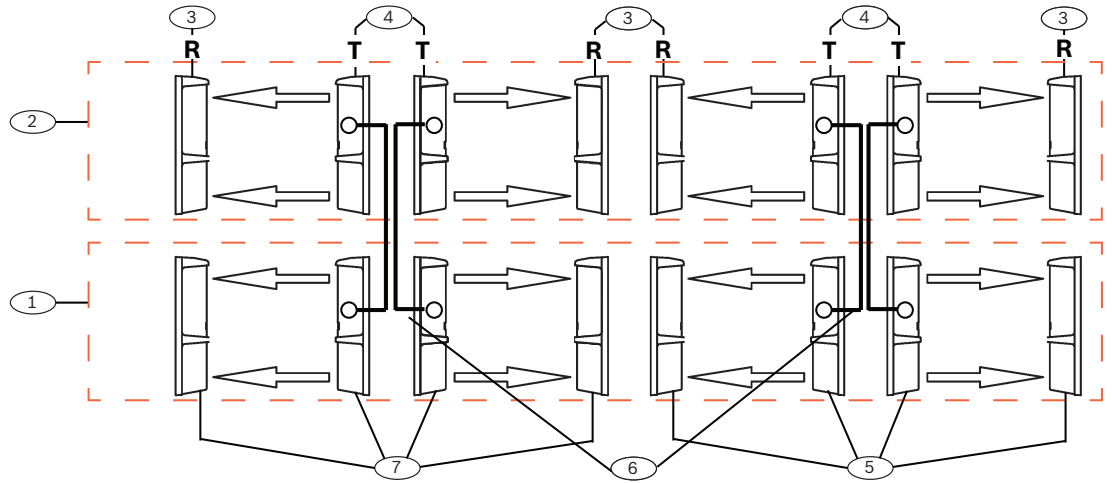

**Figure 7.6: Stacking in long distance (double stack)**

| Callout – Description                  |
|--|
| 1 – Second stack assigned to Channel 1 |
| 2 – First stack assigned to Channel M  |
| 3 – Receiver                           |
| 4 – Transmitter                        |
| 5 – Group B transmitter/receiver pairs |
| 6 – Synchro wiring                     |
| 7 – Group A transmitter/receiver pairs |

**Application**

Using a double stack configuration provides a higher level of detection when you want to secure a perimeter or an area such as a loading dock entrance of perimeter wall, and you need a higher placement position.

In double stack configurations:

- Each top set stack must be set for Channel M, and the bottom stack set to Channel 1 to avoid crosstalk between top and bottom stacks.
- Set photobeams sets in the illustration above (callout 5), to Group B to avoid crosstalk with sets assigned to Group A (callout 7).
- Use Synchro wiring as illustrated in the graphic above.

**7.4.3**

**Triple stack**

Refer to the following graphic below for a triple stack example.

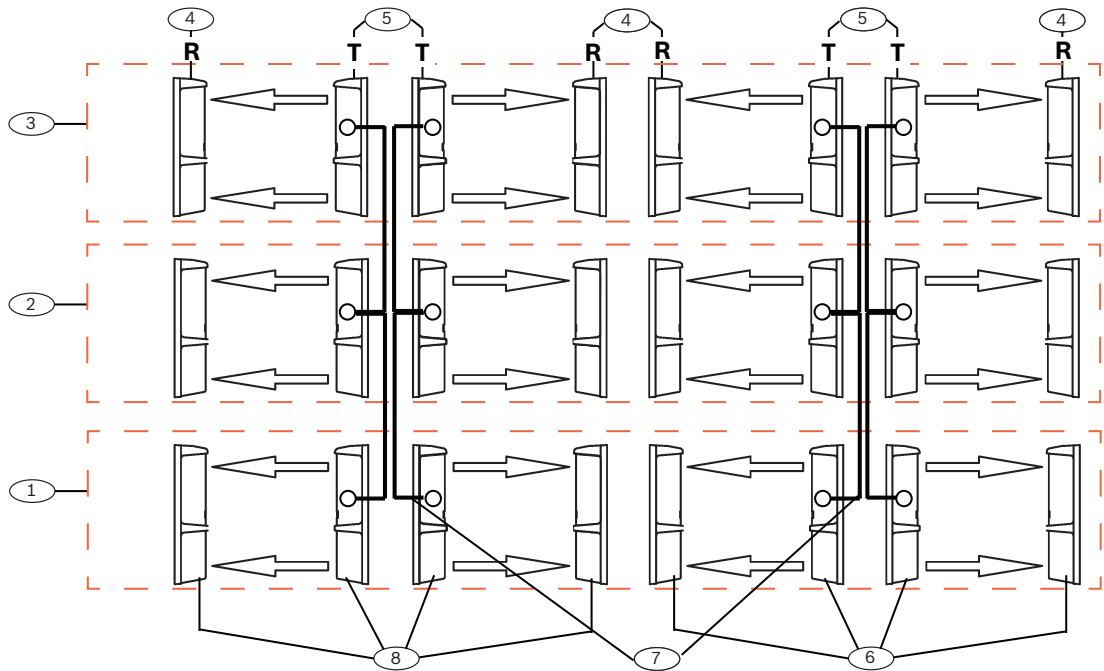

**Figure 7.7: Stacking in long distance (triple stack)**

| Callout – Description                  |
|--|
| 1 – Third stack assigned to Channel 2  |
| 2 – Second stack assigned to Channel 1 |
| 3 – First stack assigned to Channel M  |
| 4 – Receiver                           |
| 5 – Transmitter                        |
| 6 – Group B transmitter/receiver pairs |
| 7 – Synchro wiring                     |
| 8 – Group A transmitter/receiver pairs |

**Application**

Using a triple stack configuration provides an added level of detection from a double stack configuration. Use a triple stack configuration when you want to secure a perimeter or an area that has a high wall, or an environment where you need a higher placement position.

In triple stack configurations:

- Each top set stack must be set for Channel M, middle stack set to Channel 1, and the bottom stack set to Channel 2 to avoid crosstalk between the stacking sets.
- Set photobeams sets in the illustration above to Group B (callout 6) to avoid crosstalk with sets in Group A (callout 8).
- Use Synchro wiring as illustrated in the graphic above.

**7.4.4**

**Quadruple stack**

Refer to the following graphic below for a quadruple stack example.



**Stacking in long distance (quadruple stack)**

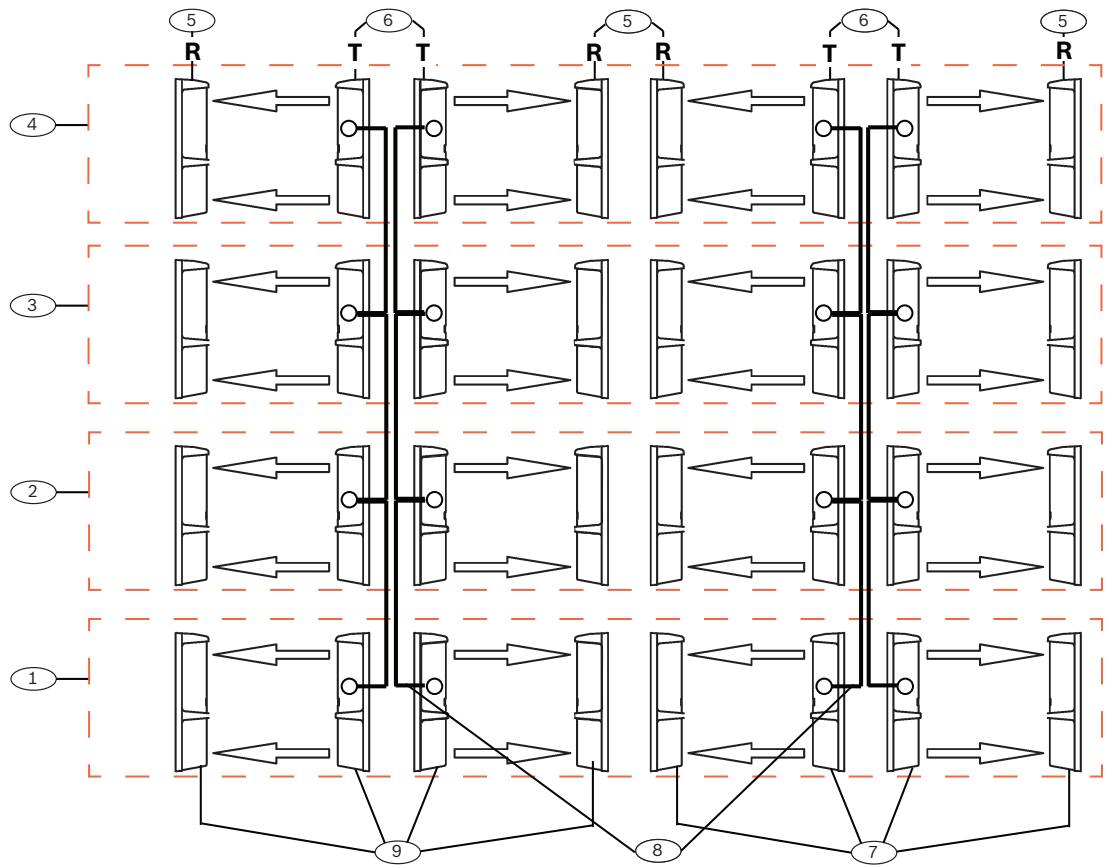

| Callout – Description                  |
|--|
| 1 – Fourth stack assigned to Channel 3 |
| 2 – Third stack assigned to Channel 2  |
| 3 – Second stack assigned to Channel 1 |
| 4 – First stack assigned to Channel M  |
| 5 – Receiver                           |
| 6 – Transmitter                        |
| 7 – Group B transmitter/receiver pairs |
| 8 – Synchro wiring                     |
| 9 – Group A transmitter/receiver pairs |

**Application**

Use a quadruple stack configuration when you want to secure a perimeter or an area that has a high wall, or an environment where you need a higher placement position.

In quadruple stack configurations:

- Each top set stack must be set for Channel M, the next stack set to Channel 1, the next stack set to Channel 2, and the bottom stack set to Channel 3 to avoid crosstalk.
- Set photobeams sets in the illustration above to Group B (callout 7) to avoid crosstalk with sets in Group A (callout 9).

- Use Synchro wiring as illustrated in the graphic above.

# 8 Optical alignment

Perform the following to align the detector.

## 8.1 Level LED – alignment of the Upper Beam

Perform the following to align the upper beam.

Aligning of the upper beam:

1. Turn on the receiver Function switch 6. The monitor LED flashes (5 times/sec).
2. Look into the scope at the center of the lens from a 10-15 cm (4-5 in) distance, adjust the horizontal direction by rotating the turntable and the horizontal adjustment screw. Adjust the vertical direction by rotating the vertical adjustment screw. Adjust until you locate the other part of the sensor in the center of the scope view.
3. Check the level LED of the receiver. Perform fine adjustments and repeat procedure until the level LED turns off. Refer to *Volt meter alignment*, page 36.

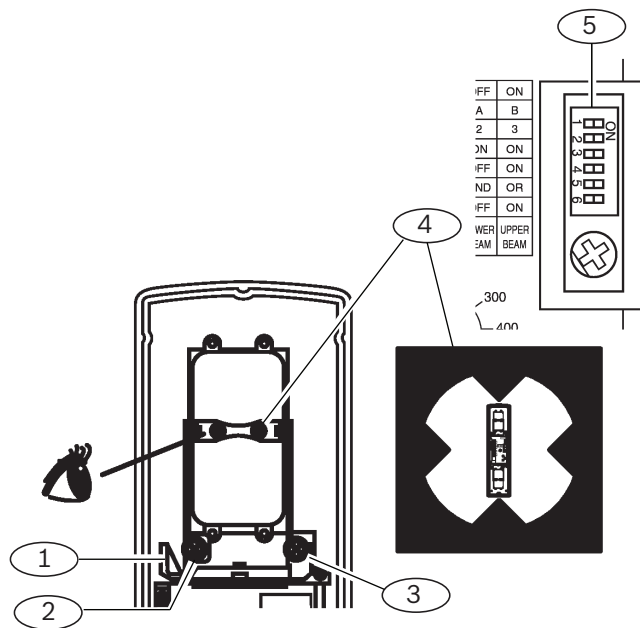

Figure 8.1: Optical alignment

| Callout – Description           | Callout – Description |
|---------------------------------|-----------------------|
| 1 – Turntable                   | 4 – Scope view finder |
| 2 – Vertical adjustment screw   | 5 – Dip switch        |
| 3 – Horizontal adjustment screw |                       |



**Notice!**

Turn on Function switches 1 and 2 of the transmitter after finishing the alignment to verify the monitor LEDs light up once every 3 seconds.

## 8.2 Level LED - alignment of the Lower Beam

Perform the following to align the lower beam.

Aligning of the lower beam:

1. Turn off the transmitter Function switch 6.
2. Follow steps 2 and 3 as listed in the *Level LED – alignment of the Upper Beam* procedure. If LED turns off, alignment is complete.

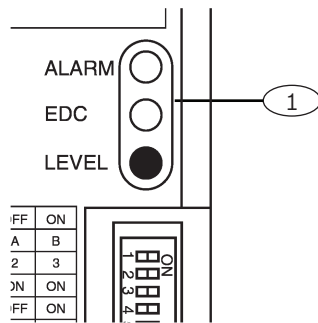

**Figure 8.2: Level LED**

| Callout – Description    |
|--------------------------|
| 1 – Receiver LED console |



**Notice!**

Turn on Function switches 1 and 2 of the transmitter after finishing the alignment to verify the monitor LEDs light up once every 3 seconds.

### 8.3 Volt meter alignment

Insert the volt meter leads into the alignment check terminals of the receiver to check voltage. If the value is 3.0 V or higher, the adjustment is completed. If less than 3.0 V, adjust the receiver and transmitter until 3.0 V is obtained.



**Notice!**

In an ideal environment, the voltage is 3.0 VDC or above.

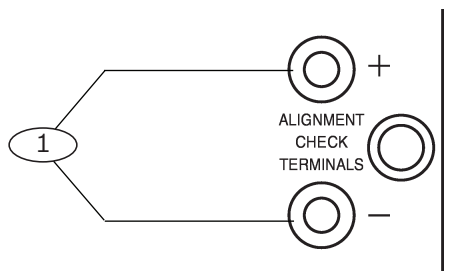

**Figure 8.3: Volt meter alignment**

| Callout – Description         |
|-------------------------------|
| 1 – Alignment check terminals |



**Notice!**

Turn on Function switches 1 and 2 of the transmitter after finishing the alignment to verify the monitor LEDs light up once every 3 seconds.

---

## 9 Operational check

Perform the following to test the overall operation of the system.

### Walk test

Testing the alarm signal:

1. Walk along the beam path near the transmitter and receiver in a pattern crossing the beam signal in three different areas as depicted in the illustration below (callout's 2, 4 and 5 – *Walk test crossing location*), and check the alarm LEDs. Refer to the *Walk test* illustration below. The alarm LED turns on each time you cross the beam path. Make sure the control panel receives an alarm signal.
2. If the alarm LED does not turn on, the beam interruption time may be set too low, or other beams are reflected into the receiver.

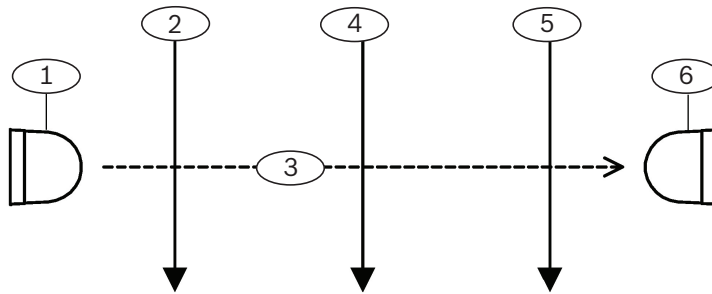

Figure 9.1: Walk test pattern

| Callout – Description             | Callout – Description             |
|-----------------------------------|-----------------------------------|
| 1 – Transmitter                   | 4 – Walk test crossing location 2 |
| 2 – Walk test crossing location 1 | 5 – Walk test crossing location 3 |
| 3 – Beam path                     | 6 – Receiver                      |

### EDC test

Testing the EDC signal:

1. Block only the upper optical module of the receiver for 3 seconds. Make sure the EDC LED on the receiver turns on.
2. When the EDC LED is ON, block the lower optical module, and confirm the alarm LED on the receiver turns on.
3. Block only the lower optical module of receiver for 3 seconds. Make sure the EDC LED on the receiver turns on. Make sure the control panel receives EDC signal from the receiver. Verify bypass feature settings. Refer to the EDC function description in *EDC (Environmental Discrimination Circuit)*, page 16.

### Tamper test

Testing the tamper detect circuit:

1. Place the cover on the detector. Verify the tamper input of the control panel indicates normal status condition.
2. Remove the cover from the detector. Verify the tamper input of the control panel detects the status change and indicates the faulted (active) condition.

## 10 Troubleshooting

In case of trouble, verify the following:

- Transmitter and receiver power supply voltage is between 10.5 – 28 V
- Transmitter monitor LED is on
- Receiver alarm LED turns on when beam is blocked
- Volume of Beam Power Control is appropriate for the set range
- Receiver level LED is off

### Troubleshooting table

| Problem                        | Cause  | Solution   |
|--------------------------------|--|--|
| Constant alarm                 | Objects are blocking the beam                                      | Remove object(s)   |
|                                | Optical modules or covers are dirty                                | Clean optical modules and covers   |
| False alarms                   | Unit misaligned  | Realign the devices  |
|                                | Intermittent blocking of the beam                                  | Remove object(s)   |
|                                | Beam interruption time is set too short                            | Increase interruption time   |
|                                | Electro-magnetic or radio frequency interference                   | Relocate devices away from noise   |
|                                | Wiring too close to power sources or power line                    | Change the wiring route  |
|                                | Unstable mounting surface  | Improve installation stability   |
|                                | Inappropriate beam power control level                             | Re-adjust the control level  |
|                                | Transmitter and receiver distance exceed the model's maximum range | Reinstall within supported range or switch to a model with greater range |
| No alarm when beams are broken | Beams are reflected into the receiver                              | Remove reflective objects or change the installation site                |
|                                | Beam interruption time is set too low                              | Increase the sensitivity   |
|                                | Other devices' beams interfere with the receiver                   | Adjust beams power or change location                                    |
| EDC activation                 | Beam interruption is set too slow                                  | Decrease interruption time   |
|                                | Objects are blocking the beams                                     | Remove object(s)   |
|                                | Unstable mounting surface  | Improve installation stability   |
|                                | Unstable installation site   | Improve installation stability   |
|                                | Transmitter and receiver distance exceed the model's maximum range | Reinstall within supported range or switch to a model with greater range |

### 10.1 Additional information

- At least once a year, clean the optical modules and covers with a soft cloth. Perform walk testing to verify correct operation.

# 11 Certifications

| Region | Agency | Certification   |
|--------|--------|---|
| US     | UL     | UL 639 Intrusion Detection Units and Systems  |
| Europe | CE     | Hereby, Bosch, declares that this transmitter is in compliance with the essential requirements and other relevant provisions of Directive 1999/5/EC |



## 12 Specifications

|                          |   |                 |                 |
|--------------------------|---|-----------------|-----------------|
| Product Name             | Photoelectric Detector  |                 |                 |
| Model                    | ISC-FPB1-W60QF  | ISC-FPB1-W120QF | ISC-FPB1-W200QF |
| Max. outdoor range       | 60 m (196 ft)   | 120 m (393 ft)  | 200 m (656 ft)  |
| Max. indoor range        | 120 m (393 ft)  | 240 m (787 ft)  | 400 m (1312 ft) |
| Transmitter current draw | 20 mA   | 24 mA           | 28 mA           |
| Receiver current draw    | 100 mA  |                 |                 |
| Power                    | 10.5VDC – 28 VDC  |                 |                 |
| Optical alignment        | +/- 90° Horizontally,+/-10° vertically  |                 |                 |
| Alarm output             | <ul style="list-style-type: none"> <li>- Form C relay (COM, NC, NO) (dry-contact)</li> <li>- Duration - 2 sec</li> <li>- Contact capacity – 30 VDC, 0.2 A (resistive load)</li> <li>- Resistance - 3.0 Ω or less</li> </ul>               |                 |                 |
| Tamper output            | <ul style="list-style-type: none"> <li>- Form B, normally closed relay (dry-contact)</li> <li>- Open when cover is open</li> <li>- Contact capacity – 30 VDC, 0.1 A (resistive load)</li> <li>- Resistance - 3.0 Ω or less</li> </ul>     |                 |                 |
| EDC output               | <ul style="list-style-type: none"> <li>- Form B, normally closed relay (dry- contact)</li> <li>- Open when EDC is activated</li> <li>- Contact capacity – 30 VDC, 0.2 A (resistive load)</li> <li>- Resistance - 3.0 Ω or less</li> </ul> |                 |                 |
| Selectable beams         | 2 Groups with 4 Channels  |                 |                 |
| Interruption time        | 40 ms to 500 ms (adjustable)  |                 |                 |
| Operating temperature    | -25° C to +60° C (-13° F to +140° F) (96% or less Relative Humidity)  |                 |                 |
| Storage temperature      | -30° C to +70° C (-22° F to 158° F) (95% or less Relative Humidity)   |                 |                 |
| IP rating (indoor)       | IP66  |                 |                 |
| Weight (each)            | 1.3 kg (2.86 lbs)   |                 |                 |
| Dimensions               | 103 x 398 x 99 mm (4.05 x 15.66 x 3.89 in)  |                 |                 |





**Bosch Security Systems, Inc.**

130 Perinton Parkway

Fairport, NY 14450

USA

**[www.boschsecurity.com](http://www.boschsecurity.com)**

© Bosch Security Systems, Inc., 2015

**Bosch Sicherheitssysteme GmbH**

Robert-Bosch-Ring 5

85630 Grasbrunn

Germany