



INSTALLATION AND OPERATION MANUAL

CNFE200(X)[POE](M,S)(1,2)[HO][/M]

2 CHANNEL 10/100 MBPS ETHERNET ELECTRICAL TO OPTICAL MEDIA CONVERTER WITH OPTIONAL POWER OVER ETHERNET (POE+)

The ComNet Ethernet CNFE200(X) media converter series are two-channel Ethernet electrical to optical media converters with optional PoE+. These auto-negotiating devices accept two 10/100 Mbps electrical inputs and convert this to a single 100 Mbps optical output. This series of media converters are available as multimode or single-mode and one and two fiber SC and ST optical connectors. The ComNet exclusive Demux feature allows for port isolation, replicating two media converters over one fiber. The ComNet exclusive Mux feature prevents network video flooding of multicast traffic with DIP switch selection of the fiber port as a dedicated uplink path. The CNFE200(X) series can be powered by wide range AC or DC input while the CNFE200(X)POE units meet the 802.3at standard and provide 30 watts of PoE+ power, with an option for a 60 watt CNFE200(X)POEHO model. The PoE models are powered by a 48 to 56 volt DC power supply (sold separately).

LED indicators confirm operational status. All models are environmentally hardened with no electrical or optical adjustments (Plug and Play). DIP Switches on the outside of each unit allow for fine-tuning of features. See **Figures 1 - 14** for complete operation details. See **Figures A and B** for mounting instructions.

FIGURE 1 - Standard Mount DC-Only Media Converter (Non-PoE)

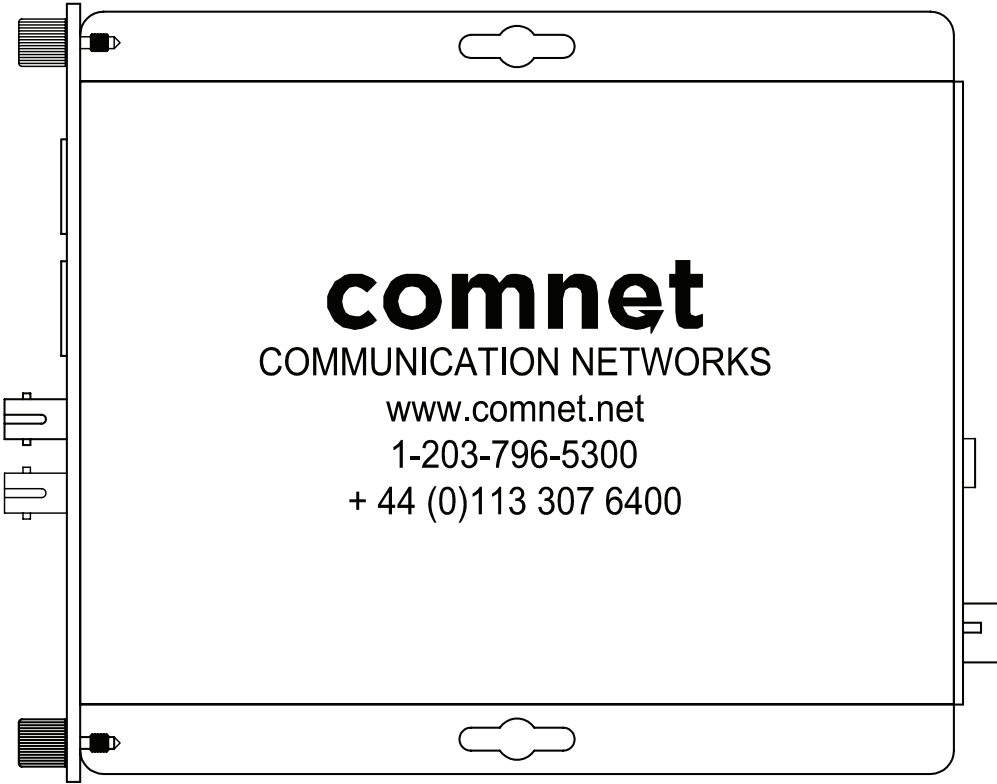

Figures on this page apply to the following model numbers:

- CNFE2002M1A
- CNFE2002M1B
- CNFE2002S1A
- CNFE2002S1B
- CNFE2003M2
- CNFE2003S2
- CNFE2004M1A
- CNFE2004M1B
- CNFE2004S1A
- CNFE2004S1B
- CNFE2005M2
- CNFE2005S2

FIGURE 2 - Standard Mount DC-Only Media Converter (Non-PoE)

FRONT PANEL

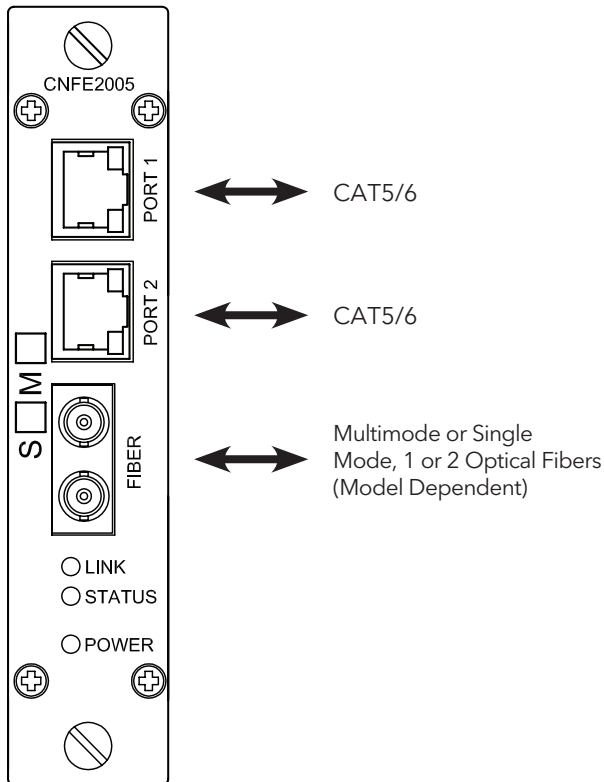

REAR PANEL

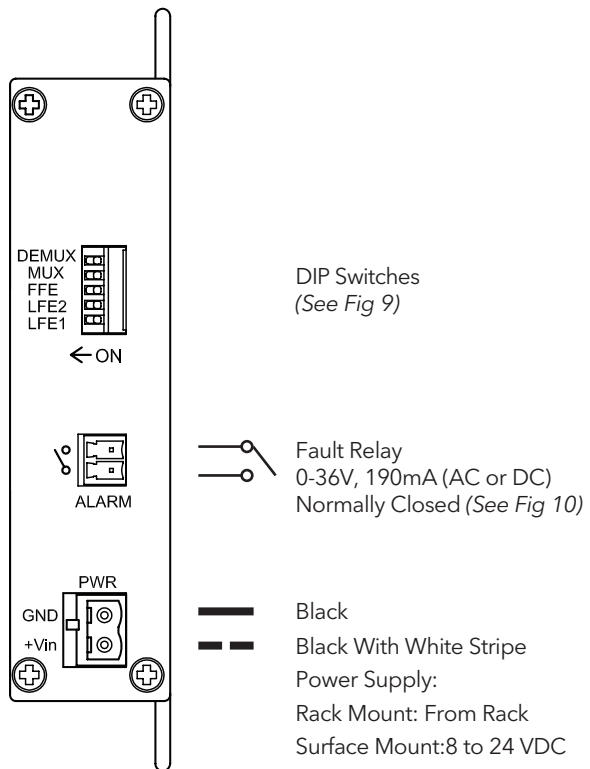
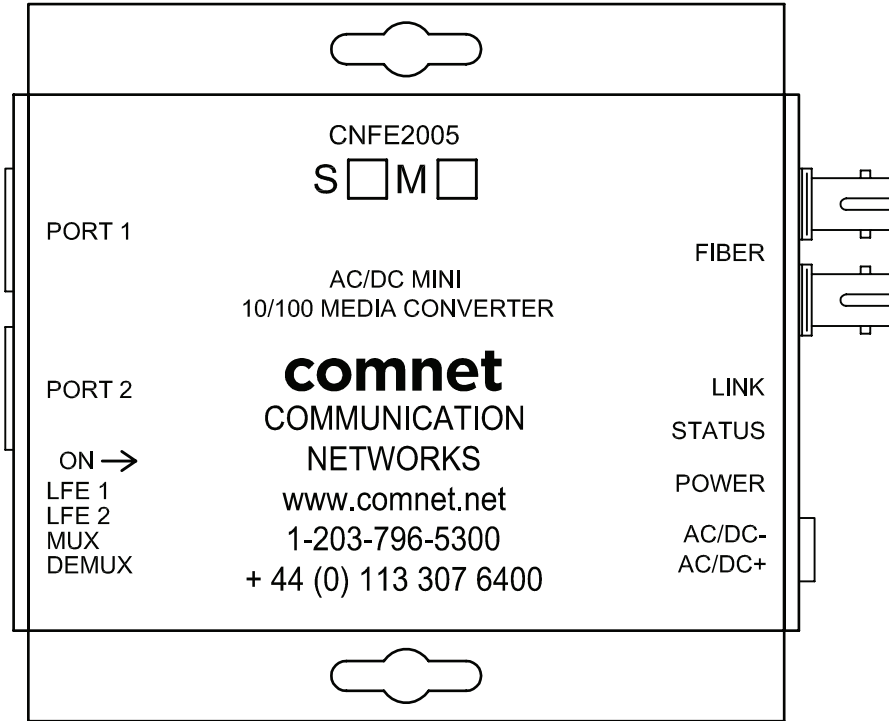

FIGURE 3 - Mini AC/DC Power Media Converter (Non-PoE)



Figures on this page apply to the following model numbers:

- CNFE2002M1A/M
- CNFE2002M1B/M
- CNFE2002S1A/M
- CNFE2002S1B/M
- CNFE2003M2/M
- CNFE2003S2/M
- CNFE2004M1A/M
- CNFE2004M1B/M
- CNFE2004S1A/M
- CNFE2004S1B/M
- CNFE2005M2/M
- CNFE2005S2/M

FIGURE 4 - Mini AC/DC Power Media Converter (Non-PoE)

FRONT PANEL

REAR PANEL

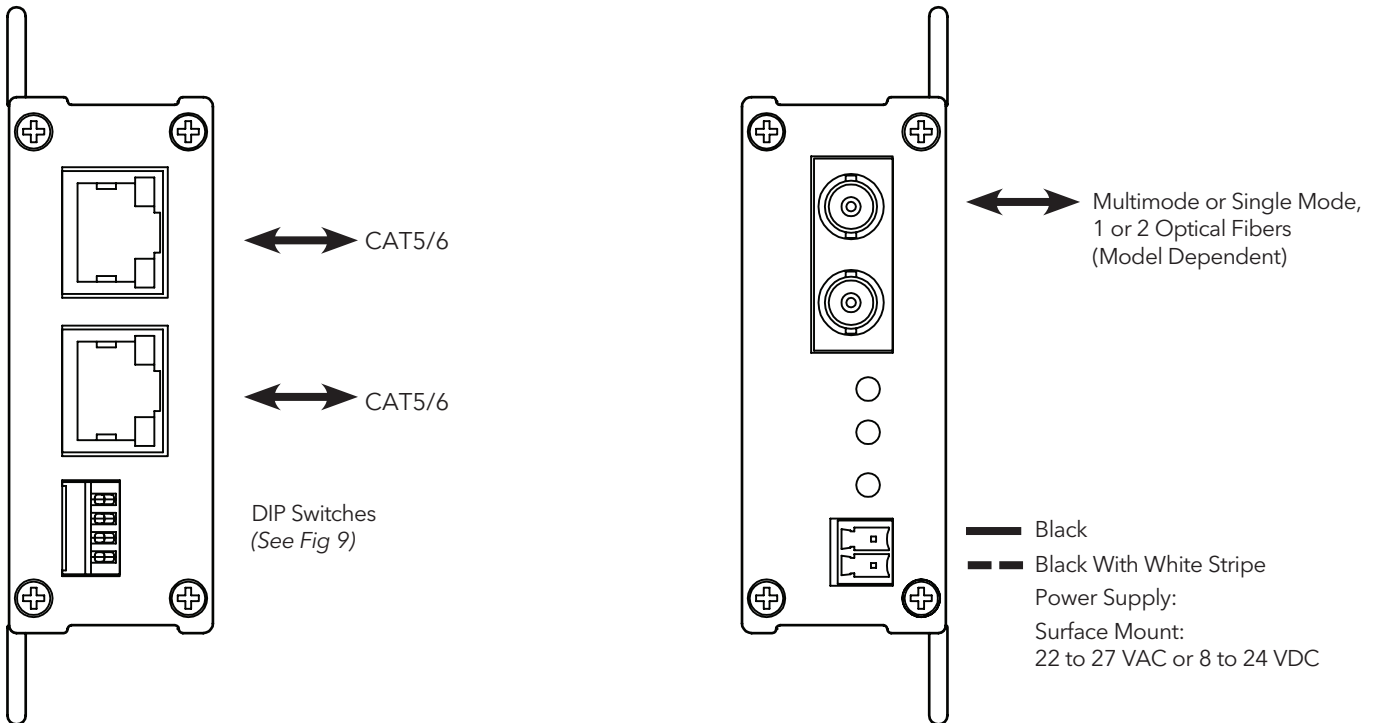
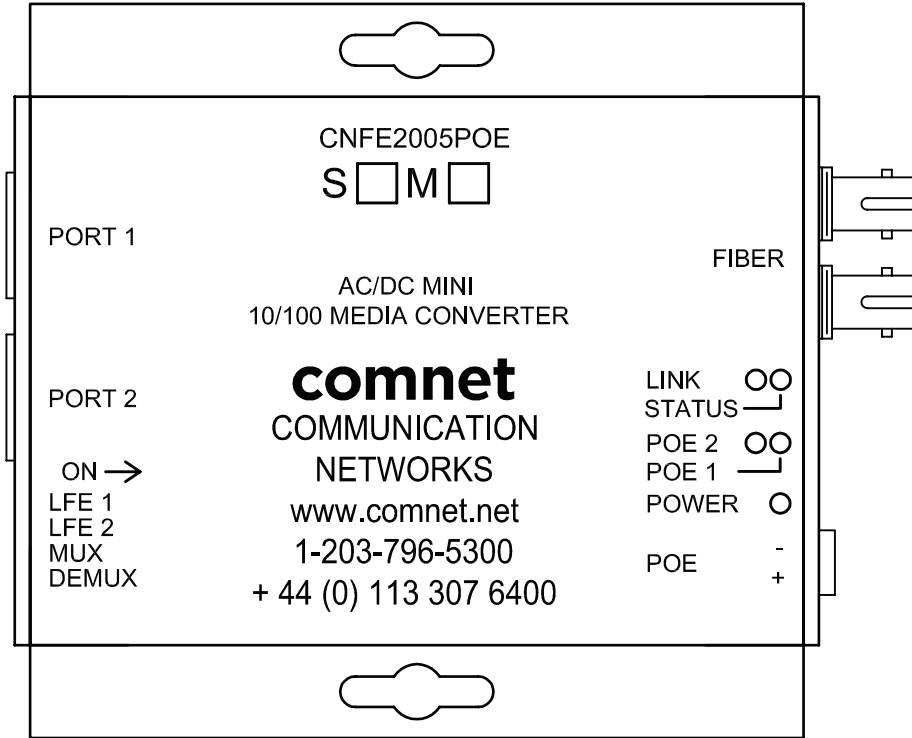

FIGURE 5 - Mini PoE Media Converter



Figures on this page apply to the following model numbers:

- CNFE2002M1APOE/M
- CNFE2002M1BPOE/M
- CNFE2002S1APOE/M
- CNFE2002S1BPOE/M
- CNFE2002M1APOEHO/M
- CNFE2002M1BPOEHO/M
- CNFE2002S1APOEHO/M
- CNFE2002S1BPOEHO/M
- CNFE2003M2POE/M
- CNFE2003S2POE/M
- CNFE2003M2POEHO/M
- CNFE2003S2POEHO/M
- CNFE2004M1APOE/M
- CNFE2004M1BPOE/M
- CNFE2004S1APOE/M
- CNFE2004S1BPOE/M
- CNFE2004M1APOEHO/M
- CNFE2004M1BPOEHO/M
- CNFE2004S1APOEHO/M
- CNFE2004S1BPOEHO/M
- CNFE2005M2POE/M
- CNFE2005S2POE/M
- CNFE2005M2POEHO/M
- CNFE2005S2POEHO/M

FIGURE 6 - Mini PoE Media Converter

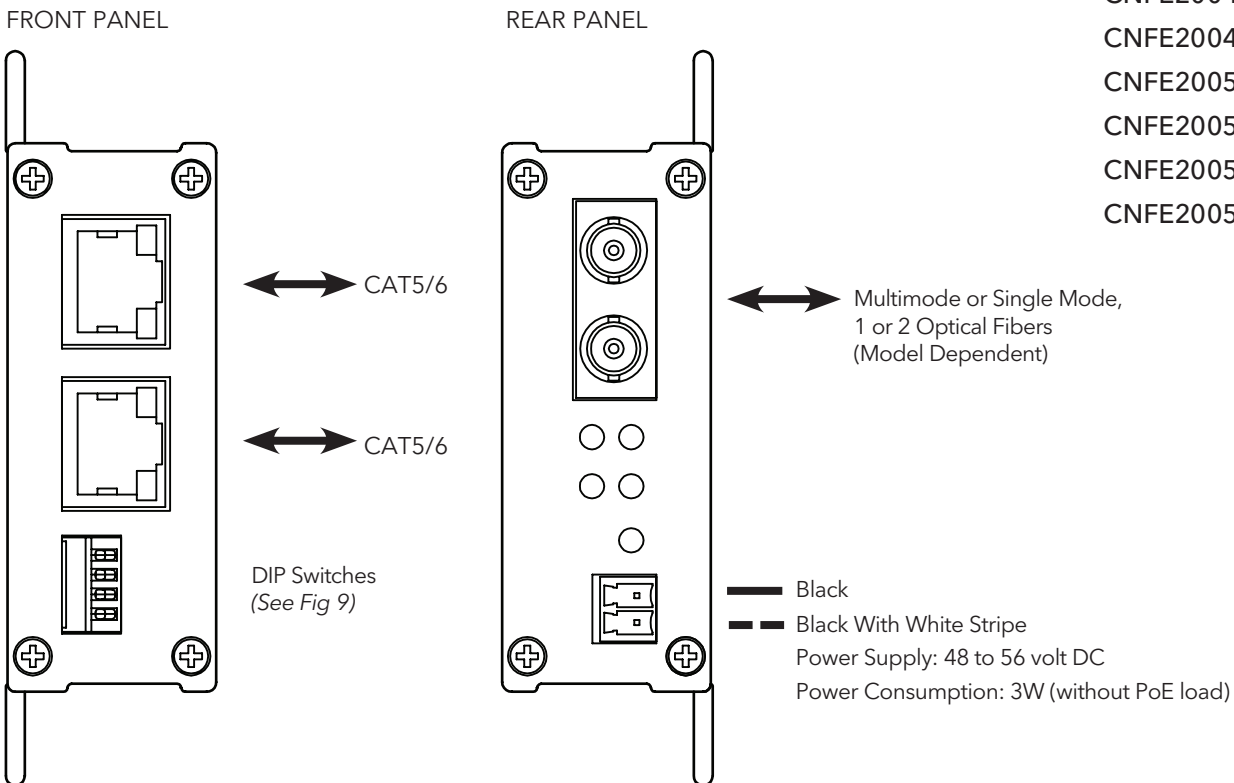

FIGURE 7 - Indicating LEDs

	LINK	STATUS (See Figures 8 & 9)	POE 1 & 2 (PoE models only)	POWER	ETHERNET LINK/ACTIVITY
GREEN	Communication link has been established over optical fiber. Flashes when data is being transmitted.	No Fault conditions detected	PoE power provided on port	Unit is correctly powered up	CNFE200(X) unit is operational
YELLOW	N/A	Fault detected (PoE models) (One or more DIP Switch relays must be enabled)	N/A	N/A	Fiber failure or copper failure (Link Fault DIP Switch must be Enabled / ON)
RED	N/A	Fault detected (non-PoE models) (One or more DIP Switch relays must be enabled)	N/A	N/A	N/A
OFF	Communication link has not been established.	Unit not correctly powered up	PoE power not provided.	Unit not correctly powered up	Unit not correctly powered up.

FIGURE 8 - DIP Switches (CNFE200(X) Standard Size Units Only)

SW	NAME	OFF (DOWN)	ON (UP)
1	LINK FAULT ENABLE PORT 1	Link Fault Pass-Through Disabled	Link Fault Pass-Through Enabled. If the Copper Port is Down or Not Connected, the Optical Port will turn on and off at a ~1 sec rate to indicate copper port 1 fault.
2	LINK FAULT ENABLE PORT 2	Link Fault Pass-Through Disabled	Link Fault Pass-Through Enabled. If the Copper Port is Down or Not Connected, the Optical Port will turn on and off at a ~1 sec rate to indicate copper port 2 fault.
3	FFE	Fiber Fault Relay Disabled	Fiber Fault Relay Enabled. If the optical link is lost or there is a power failure then the alarm relay output will be triggered.
4	MUX	MUX Disabled	Mux Enabled. All Ethernet traffic is diverted from the copper ports to the fiber port, copper-to-copper traffic will be disabled.
5	DEMUX	DEMUX Disabled	DeMux Enabled. When two CNFE200(X) units are connected via fiber and both have DeMux enabled, traffic from Port 1 will go to Port 1 and traffic from Port 2 will go to Port 2 only, functioning like two separate media converters over one fiber.

FIGURE 9 - DIP Switches (CNFE200(X)/M Small Size Units Only)

SW	NAME	OFF (DOWN)	ON (UP)
1	LINK FAULT ENABLE PORT 1	Link Fault Pass-Through Disabled	Link Fault Pass-Through Enabled. If the Copper Port is Down or Not Connected, the Optical Port will turn on and off at a ~1 sec rate to indicate copper port 1 fault.
2	LINK FAULT ENABLE PORT 2	Link Fault Pass-Through Disabled	Link Fault Pass-Through Enabled. If the Copper Port is Down or Not Connected, the Optical Port will turn on and off at a ~1 sec rate to indicate copper port 2 fault.
3	MUX	MUX Disabled	Mux Enabled. All Ethernet traffic is diverted from the copper ports to the fiber port, copper-to-copper traffic will be disabled.
4	DEMUX	DEMUX Disabled	DeMux Enabled. When two CNFE200(X) units are connected via fiber and both have DeMux enabled, traffic from Port 1 will go to Port 1 and traffic from Port 2 will go to Port 2 only, functioning like two separate media converters over one fiber.

FIGURE 10 - Fault Relay Operation (CNFE200(X) Standard Size Units Only)



The fault relay is normally closed and will open on any of the following alarm conditions:

- Link Fault is enabled on the **remote** CNFE200(X) unit and a copper port has been disconnected.
- Link Fault is enabled on the **local** CNFE200(X) unit and a copper port has been disconnected.
- Fiber Fault is enabled on the **local** CNFE200(X) unit and the fiber link is down or the power has been lost to either the local or remote CNFE200(X) unit.

FIGURE 11 - MUX Disabled

Multicast traffic will be flooded on all ports.

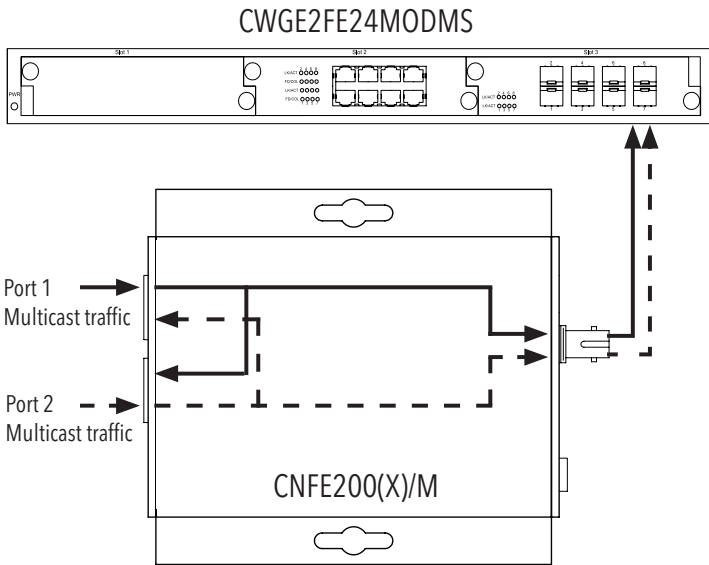

FIGURE 12 - MUX Enabled

IGMP is Enabled on the CWGE2FE24MODMS Managed Switch. Multicast traffic is diverted only to the fiber port preventing flooding on the local device.

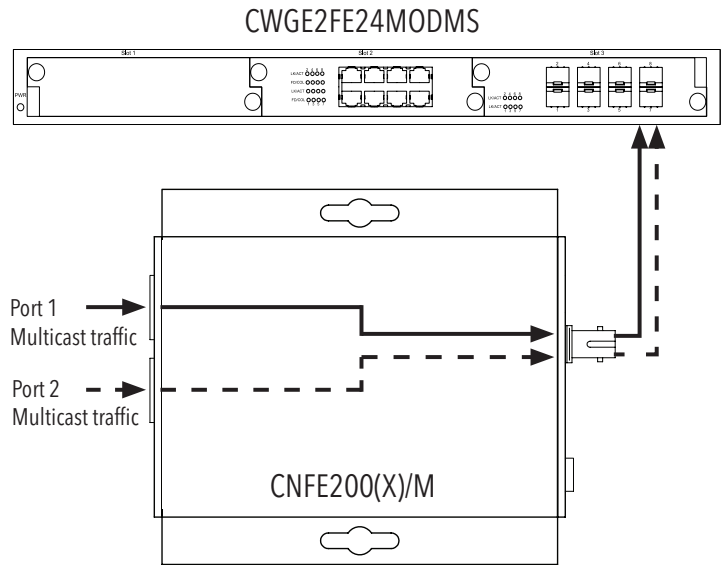

FIGURE 13 - DEMUX Disabled

Traffic can be sent/received on all electrical and fiber ports.

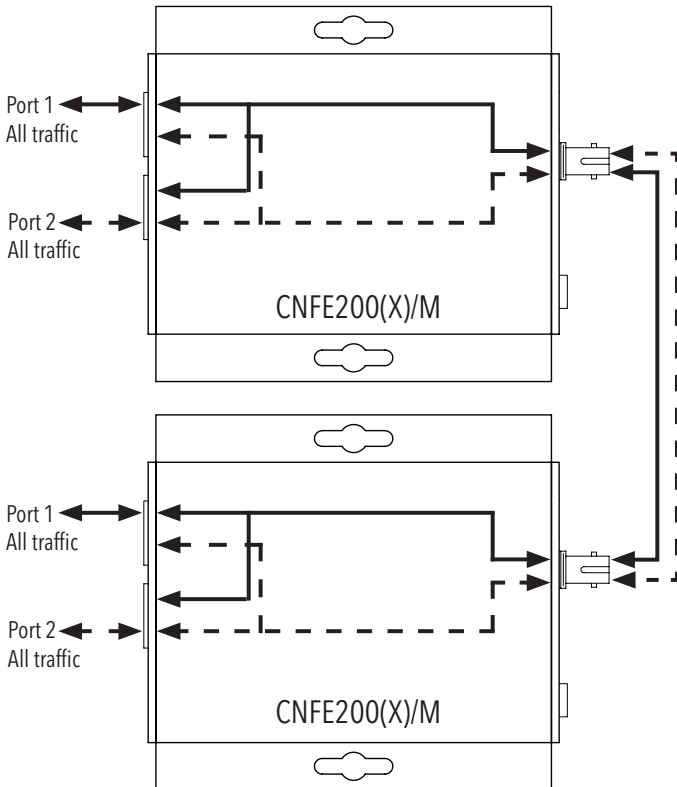
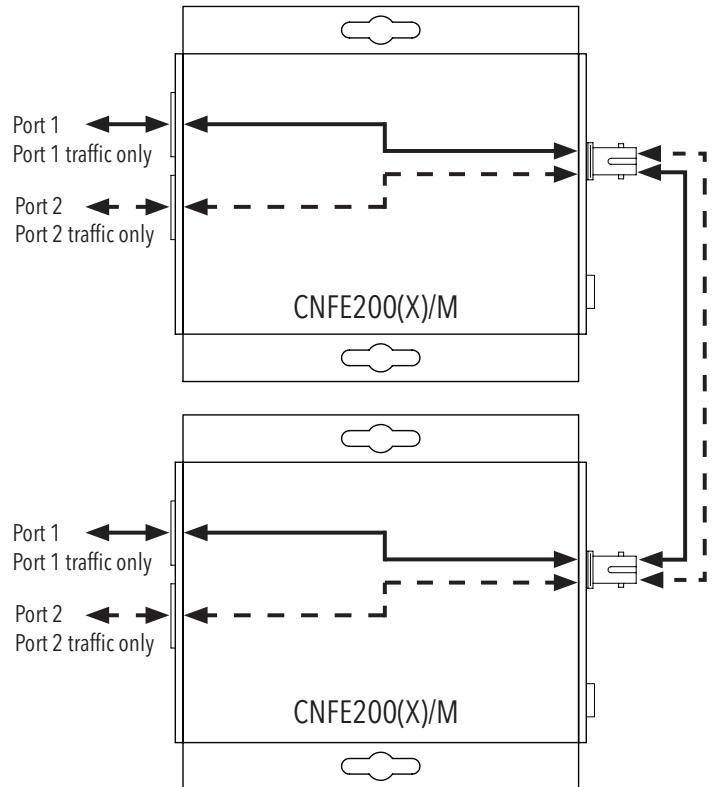

FIGURE 14 - DEMUX Enabled

Traffic from Port 1 will go only to Port 1 and traffic from Port 2 will go only to Port 2 only, functioning like two separate media converters over one fiber.



MECHANICAL INSTALLATION INSTRUCTIONS

INSTALLATION CONSIDERATIONS

This fiber-optic link is supplied as Standalone/Surface Mount and Surface Mount/Rack Mount modules. Units should be installed in dry locations protected from extremes of temperature and humidity.

C1-US, C1-EU, C1-AU or C1-CH Card Cage Racks

CAUTION: Although the units are hot-swappable and may be installed without turning power off to the rack, ComNet recommends that the power supply be turned off and that the rack power supply is disconnected from any power source. Note: Remove electrical connector before installing in card cage rack.

1. Make sure that the card is oriented right side up, and slide it into the card guides in the rack until the edge connector at the back of the card seats in the corresponding slot in the rack's connector panel. Seating may require thumb pressure on the top and bottom of the card's front panel.

CAUTION: Take care not to press on any of the LEDs.

2. Tighten the two thumb screws on the card until the front panel of the card is seated against the front of the rack.

WARNING: Unit is to be used with a Listed Class 2 power supply.

IMPORTANT SAFEGUARDS:

A) Elevated Operating Ambient - If installed in a closed or multi-unit rack assembly, the operating ambient temperature of the rack environment may be greater than room ambient. Therefore, consideration should be given to installing the equipment in an environment compatible with the maximum ambient temperature (T_{ma}) specified by the manufacturer.

B) Reduced Air Flow - Installation of the equipment in a rack should be such that the amount of air flow required for safe operation of the equipment is not compromised.



FIGURE A

Dimensions are for a standard ComNet one slot module

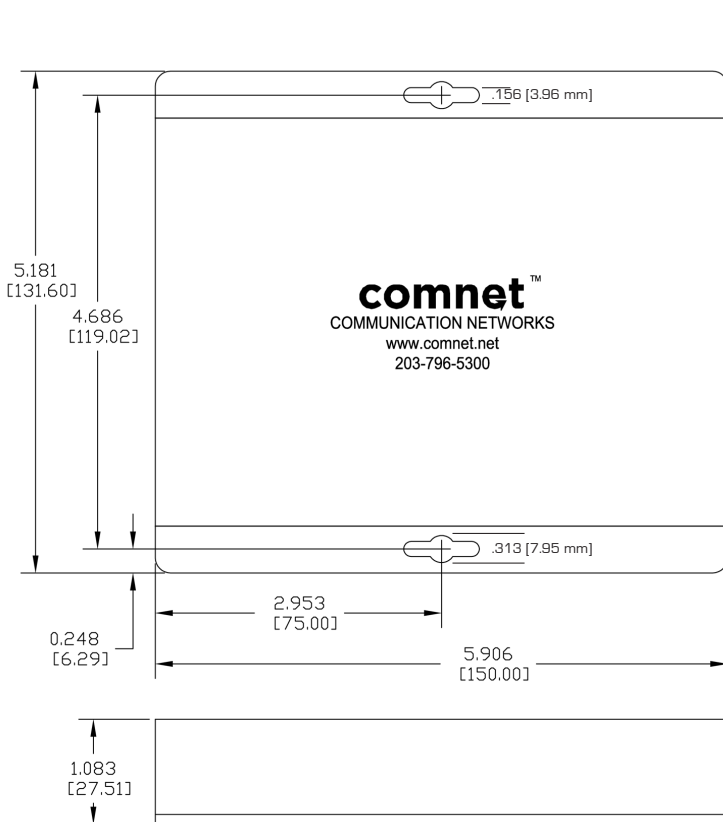
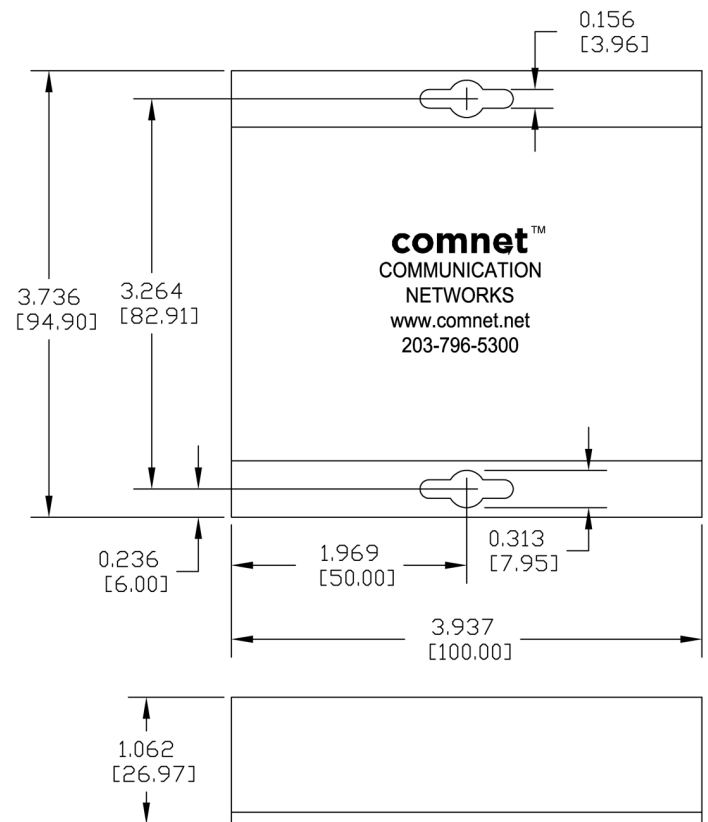

FIGURE B

Dimensions are for a small size ComNet surface mount module



3 CORPORATE DRIVE | DANBURY, CT 06810 | USA
 T: 203.796.5300 | F: 203.796.5303 | TECH SUPPORT: 1.888.678.9427 | INFO@COMNET.NET
 8 TURNBERRY PARK ROAD | GILDERSOME | MORLEY | LEEDS, UK LS27 7LE
 T: +44 (0)113 307 6400 | F: +44 (0)113 253 7462 | INFO-EUROPE@COMNET.NET