

INSTALLATION AND OPERATION MANUAL

FDW1000(M,S)

OPTICAL WIEGAND, MAGSTRIPE & F/2F DATA EXTENDER

This manual serves the following ComNet Model Numbers:

FDW1000M/C
FDW1000S/C
FDW1000M/R
FDW1000S/R
EXP100C
EXP100R

The ComNet™ FDW1000 data extenders provide optical connectivity between one card reader and its associated door or gate locking hardware, to any Wiegand, MagStripe, or F/2F-based control panel. The connection is completely supervised and secure, and a pair of these units will support a single locking gate or door and its associated reader using two multimode or singlemode optical fibers. The ComNet™ EXP100 Expansion Module enables additional Wiegand-based devices to be added to the network.

An auxiliary I/O (input/output) interface is available for determining door, gate, and control panel status and signaling, and a relay interface provides the door strike or gate activation functions. See **Figures 10** and **11** beginning on **Page 5** for a guide to the I/Os and Relay Controls.

The FDW1000 series are supplied as a remote unit for door or gate locations, and a central unit for control panel installation, managed by use of a Dip Switch on each unit. See **Figures 3** through **5** on **Page 3** for Central and Remote Dip Switch Settings.

These extenders are designed for long-term, reliable operation in harsh industrial environments, and a fault-specific LED indicator is provided for rapidly ascertaining the operating status of the extender and the link. See **Figure 17** on **Page 12** for an explanation of LED indicators.

Packaged in a rugged aluminum housing, these units are designed for shelf or surface mounting. See **Figure A** on **Page 12** for mounting instructions.

See **Figures 1 - 17** for complete installation details.

FIGURE 1 - FDW1000/C CENTRAL DATA EXTENDER

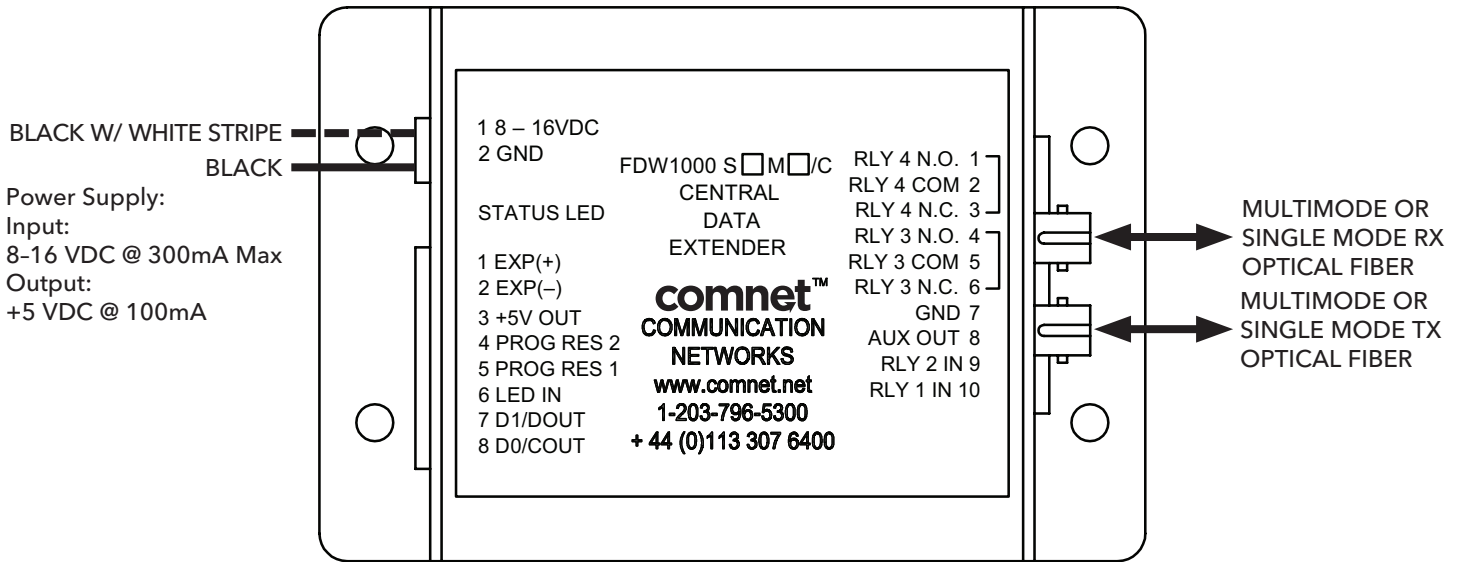

Optical Port TX must be connected to Optical Port RX on another FDW1000 unit. Similarly, Optical Port RX must be connected to Optical Port TX on another FDW1000 unit. See Figure 8 on Page 4.

FIGURE 2 - FDW1000/R REMOTE DATA EXTENDER

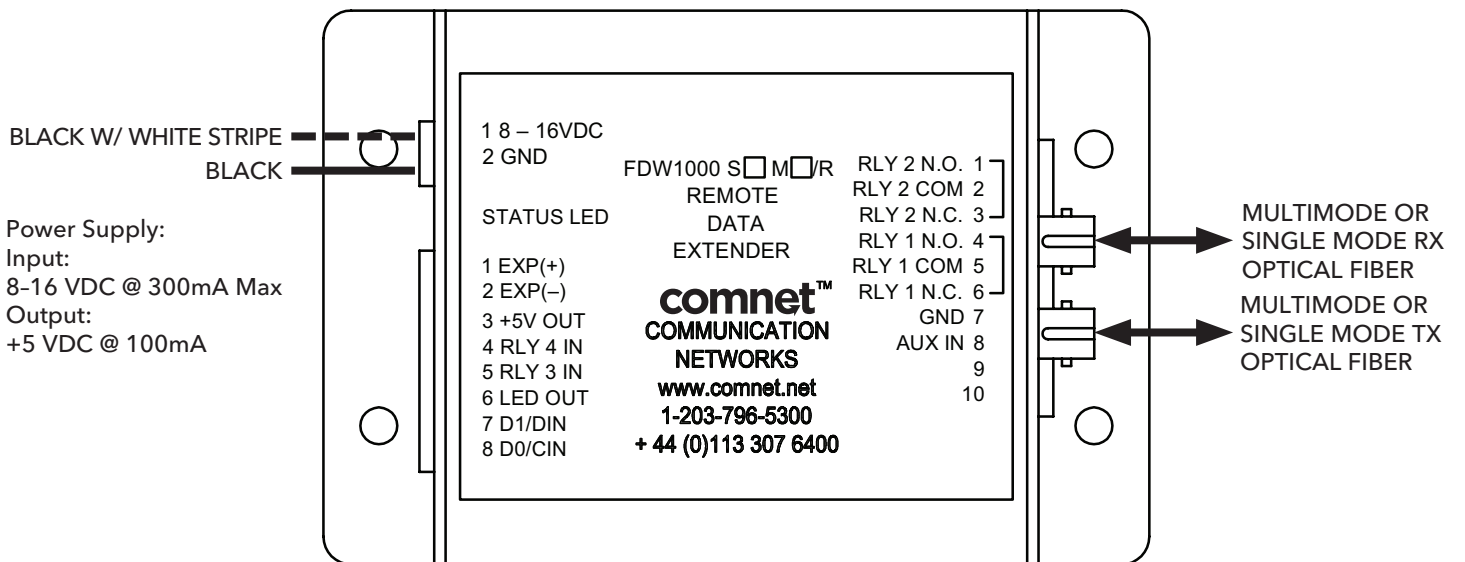

Optical Port TX must be connected to Optical Port RX on another FDW1000 unit. Similarly, Optical Port RX must be connected to Optical Port TX on another FDW1000 unit. See Figure 8 on Page 4.

FIGURE 3 - CENTRAL UNIT SWITCH SETTINGS

Dip Switch is located beneath the casing of each unit.

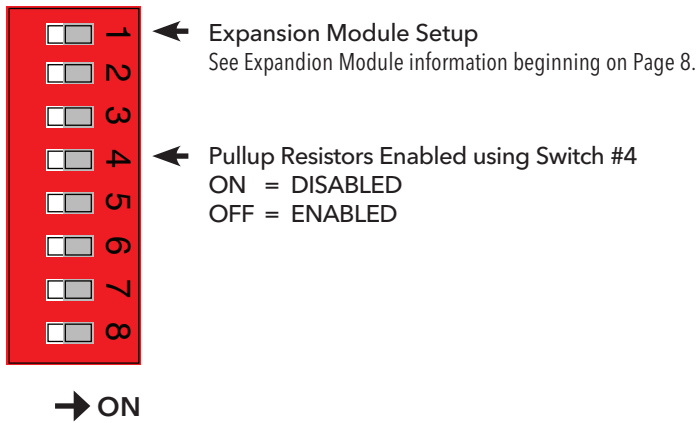

FIGURE 4 - REMOTE UNIT SWITCH SETTINGS

Dip Switch is located beneath the casing of each unit.

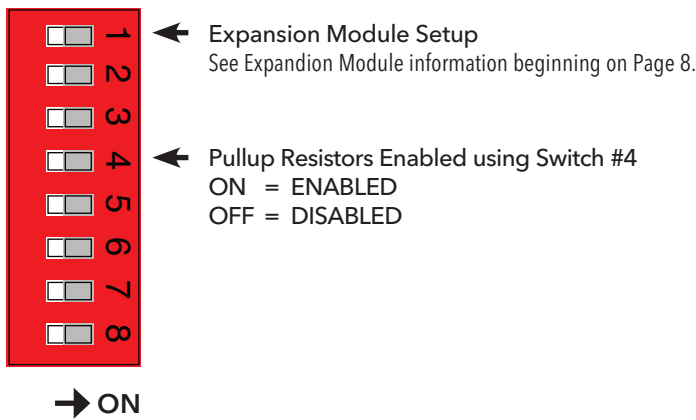
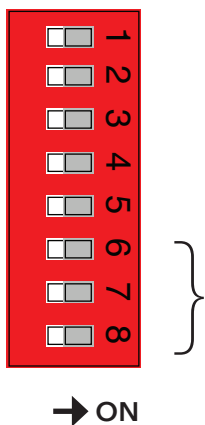

FIGURE 5 - DATA I/O SWITCH SETTINGS

Dip Switch is located beneath the casing of each unit. Data selection is made using switches 6, 7 and 8.



	Switch		
	6	7	8
Wiegand	OFF	OFF	OFF
Wiegand / No Filter	OFF	OFF	ON
Strobed Rising Edge (MR-5)	OFF	ON	OFF
Strobed Rising Edge (Dorad0 644)	OFF	ON	ON
Strobed Rising (Mag-Tek)	ON	OFF	OFF
Strobed Falling Edge	ON	OFF	ON
Reserved	ON	ON	OFF
F2F	ON	ON	ON

FIGURE 6 - FDW1000/C TYPICAL CONNECTION

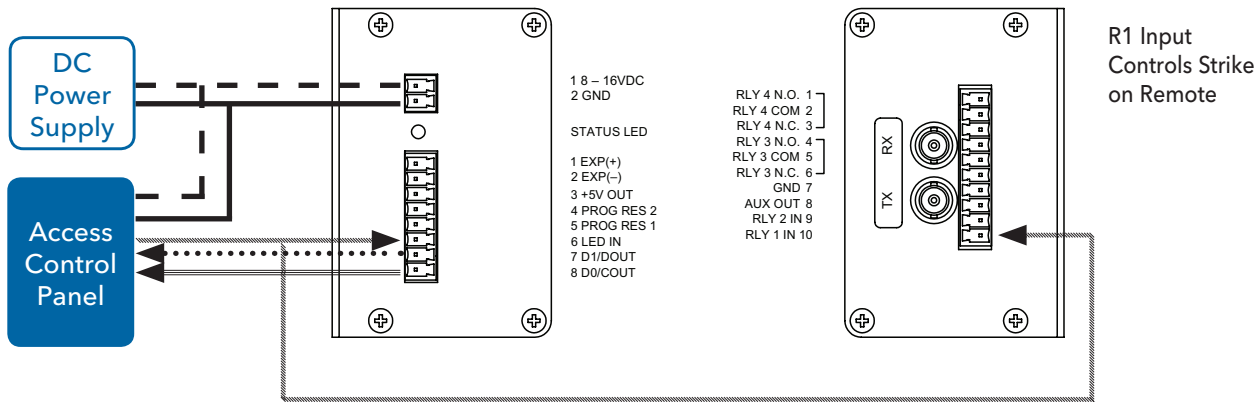

FIGURE 7 - FDW1000/R TYPICAL CONNECTION

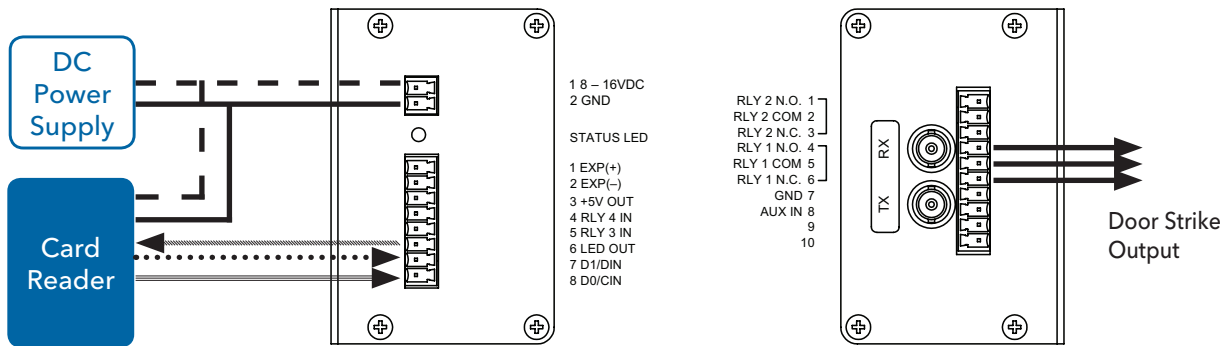
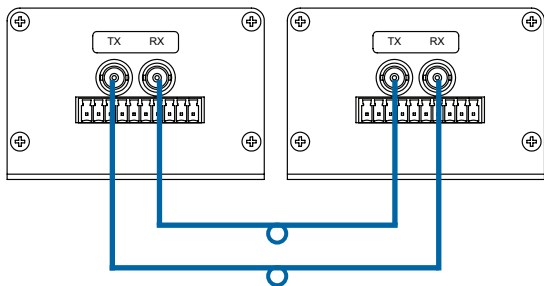

FIGURE 8 - OPTIC CONNECTIONS



Bench Test and Set Up:

1. Connect the Remote and Central unit Fiber Optic ports together using a crossover connection as shown in the diagram.
2. Connect a suitable power supply to both units.
3. Apply power. After a short delay, both units' Status LEDs should flash with a green pulse to indicate successful communication.
4. Touch a jumper wire from the GND connection to the RLY 3 input on the FDW1000/C. The relay should activate with an audible click. A VOM or continuity tester should show RLY 1 N.O. Contacts on the FDW1000/R closing when the RLY 1 input is connected to GND on the FDW1000/C.
5. FDW1000 ships preset for Wiegand data format. Refer to Figure 5 on Page 3 to set the Dip Switch to a different reader and panel format.
6. Connect a reader to the FDW1000/R and a panel to the FDW1000/C. Verify that card reads are being accepted by the access control system. Perform any troubleshooting before installing the units in the field.
7. If the EXP100 Expansion modules are used with this system, refer to EXP100 integration information beginning on Page 8.
8. When proper settings are verified, units are ready for final installation and operation.

FIGURE 9 - TEMPERATURE RATING vs. VOLTAGE DERATING CURVE

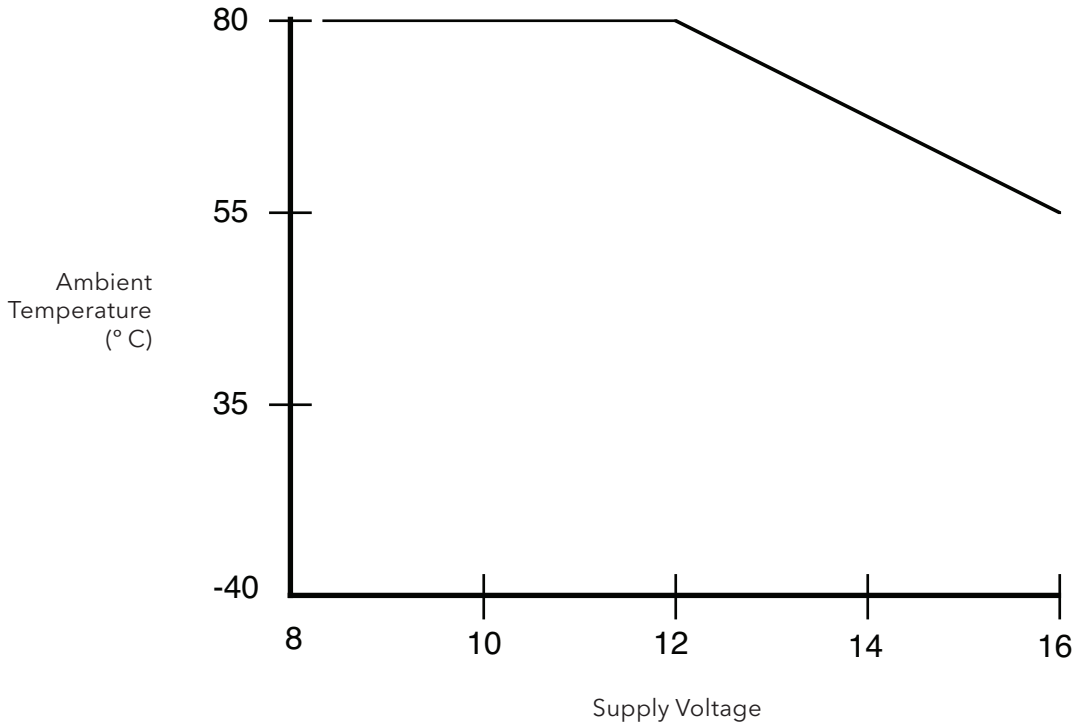

The FDW1000 should be operated with a filtered 12 VDC power supply. Any voltage between 8 and 16 Voltes can be utilized by following this curve. Voltage should not exceed 16 VDC under normal operating conditions.

FIGURE 10 - DOOR STRIKE AND LED I/O

Only Relay and LED Connections are shown for clarity. Refer to Figures 6 & 7 on Page 4 for Power and Data Connections.

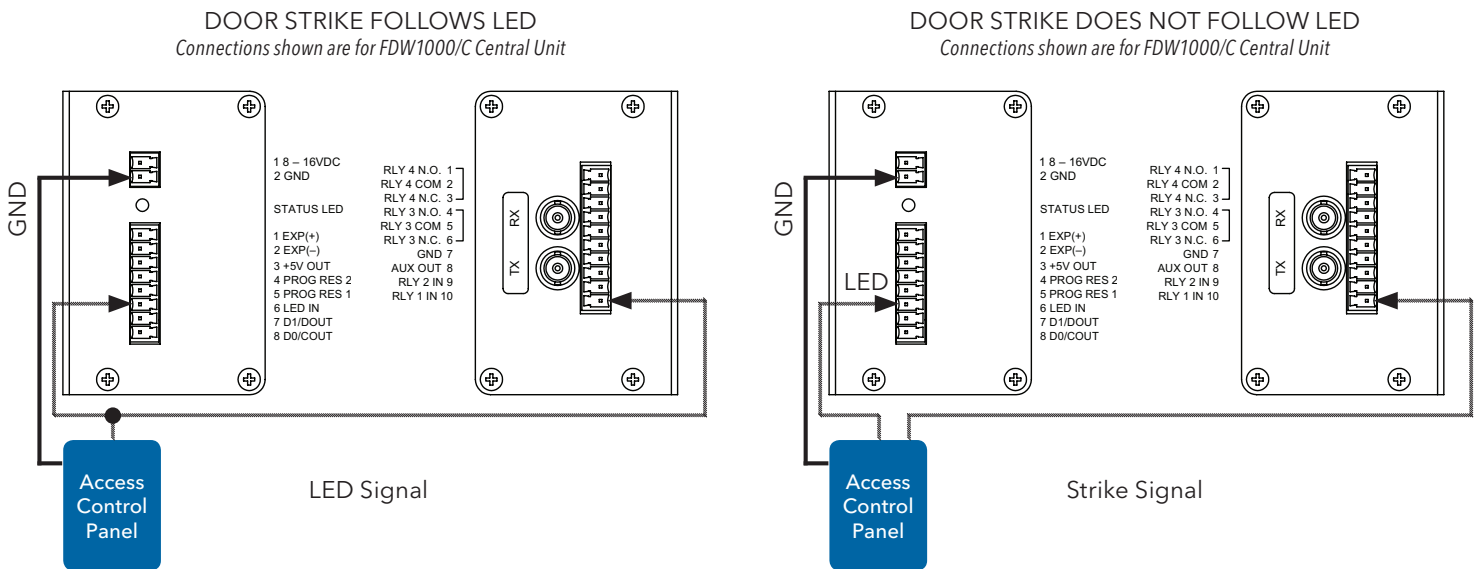
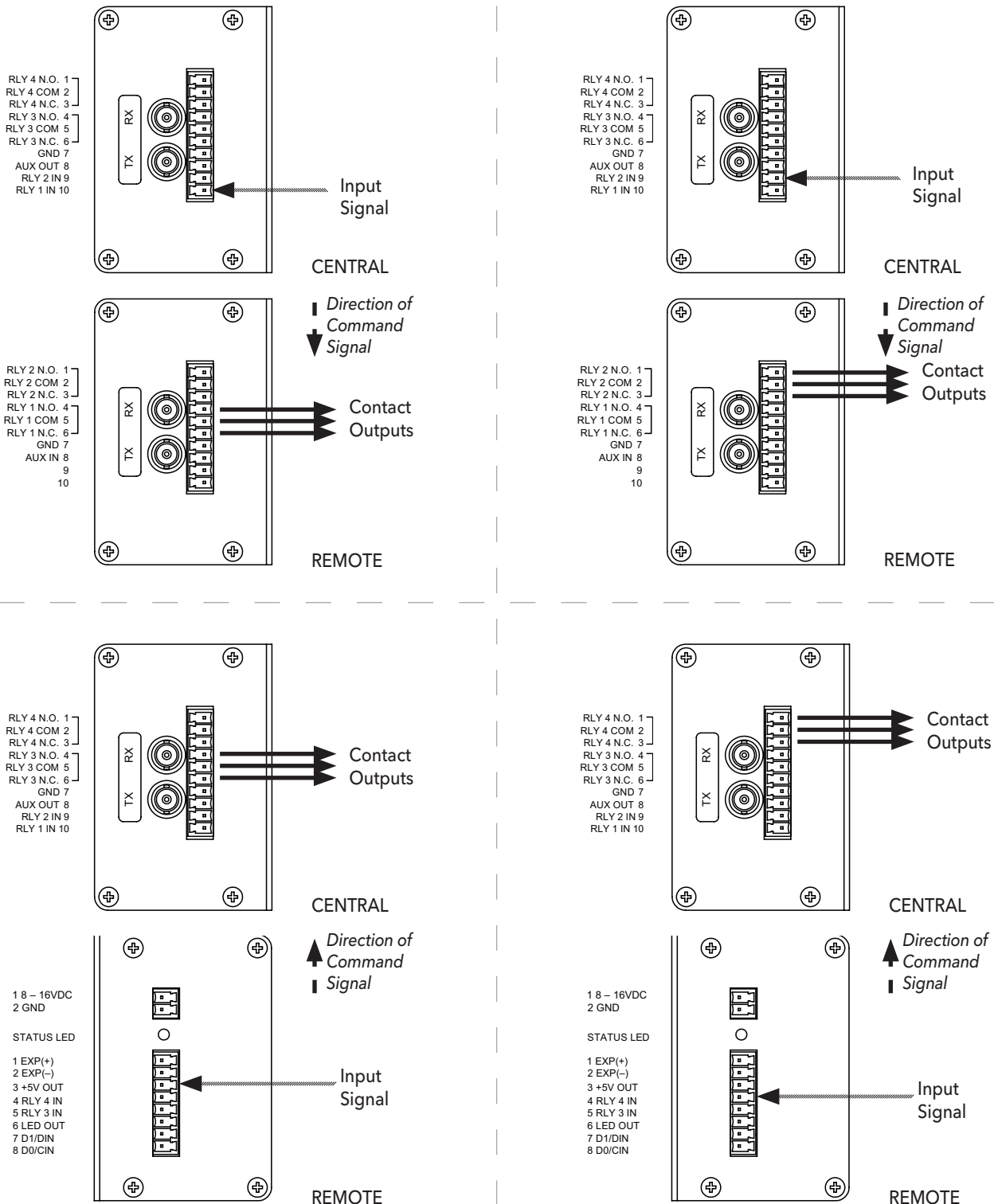

FIGURE 11 - RELAY CONTROLS



NOTE: FDW1000/C's RLY 3 functions as an Alarm relay and monitors the condition of the communication link between the FDW1000/C and FDW1000/R units.

It is activated when power is applied and the communication link between the FDW1000/C and FDW1000/R is functioning.

It becomes deactivated (Alarm Condition) when the RLY 3 IN input on the FDW1000/R is active OR when the FDW1000/R unit is unable to communicate with the FDW1000/C unit.

FIGURE 12 - SUPERVISED CONTACTS

The system provides a supervised signal to the panel interface by reading the supervised status of the contacts connected to the FW1000/R unit.

CENTRAL

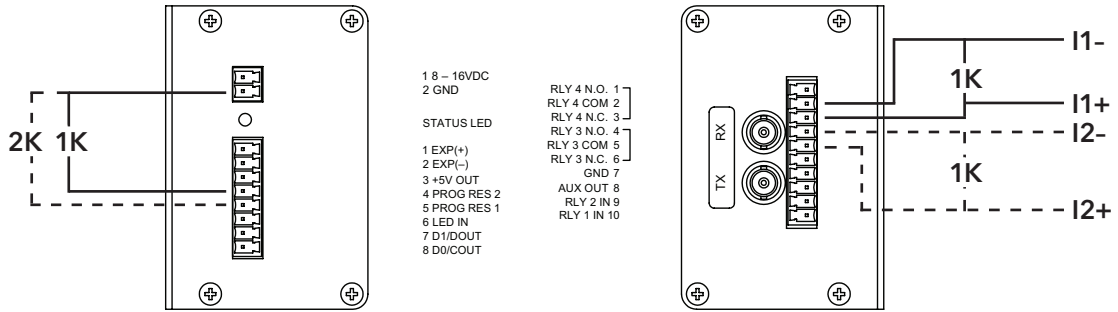

REMOTE

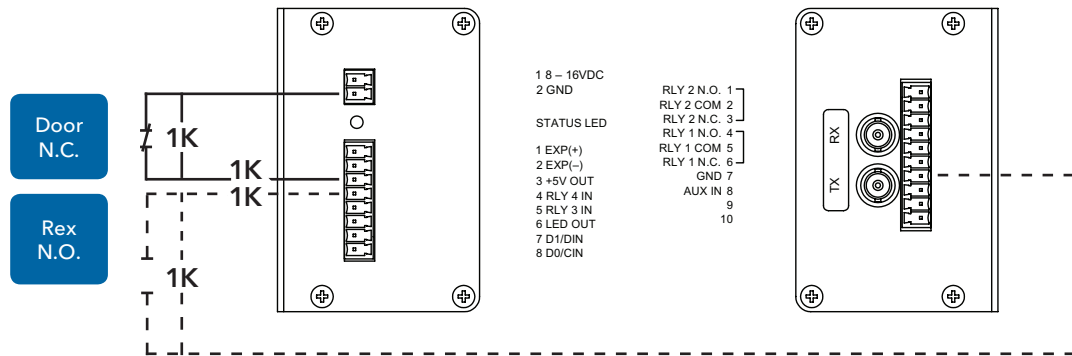

SETUP EXP100

Configuration Process:

1. With power off, set the Dip Switch on the Central unit according to the table below.
2. Apply Power. The Status LED should display a steady Green indication.
3. Remove Power. Set Dip Switch #1 to OFF. Any other Dip Switches can now be set as required (Reader family/ Pullup resistors). The FDW1000/C is now configured. No configuration is necessary for the FDW1000/R.
4. Configure the EXP100 expansion module according to that product's manual.
5. Connect the Expansion modules into the system as indicated in Figures 15 and 16 beginning on Page 9.

Operation:

The FDW1000 series Remote and Central units will operate as a standard pair, with all of the I/O and data terminals available for use with readers and access control systems. With the expansion module:

- The Status LED on the FDW1000 units will indicate the status of the main (gateway) communication link only.
- The Alarm relay on the Central gateway unit will deactivate (indicate alarm condition) when the communication fails between the gateway units or ANY of the Remote or Central EXP100 units.

FIGURE 13 - FDW1000/C SWITCH SETTINGS WHEN USED WITH EXP100

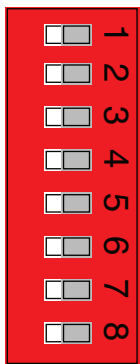

→ ON

	Switch							
	1	2	3	4	5	6	7	8
Gateway Only - No EXP	ON	OFF	OFF	ON	OFF	OFF	OFF	OFF
1 EXP100 Pair Used	ON	OFF	OFF	ON	OFF	OFF	OFF	ON
2 EXP 100 Pairs Used	ON	OFF	OFF	ON	OFF	OFF	ON	OFF
3 EXP Pairs Used	ON	OFF	OFF	ON	OFF	OFF	ON	ON
4 EXP Pairs Used	ON	OFF	OFF	ON	OFF	ON	OFF	OFF
5 EXP Pairs Used	ON	OFF	OFF	ON	OFF	ON	OFF	ON
6 EXP Pairs Used	ON	OFF	OFF	ON	OFF	ON	ON	OFF
7 EXP Pairs Used	ON	OFF	OFF	ON	OFF	ON	ON	ON

FIGURE 14 - TYPICAL APPLICATION IN CONJUNCTION WITH EXP100

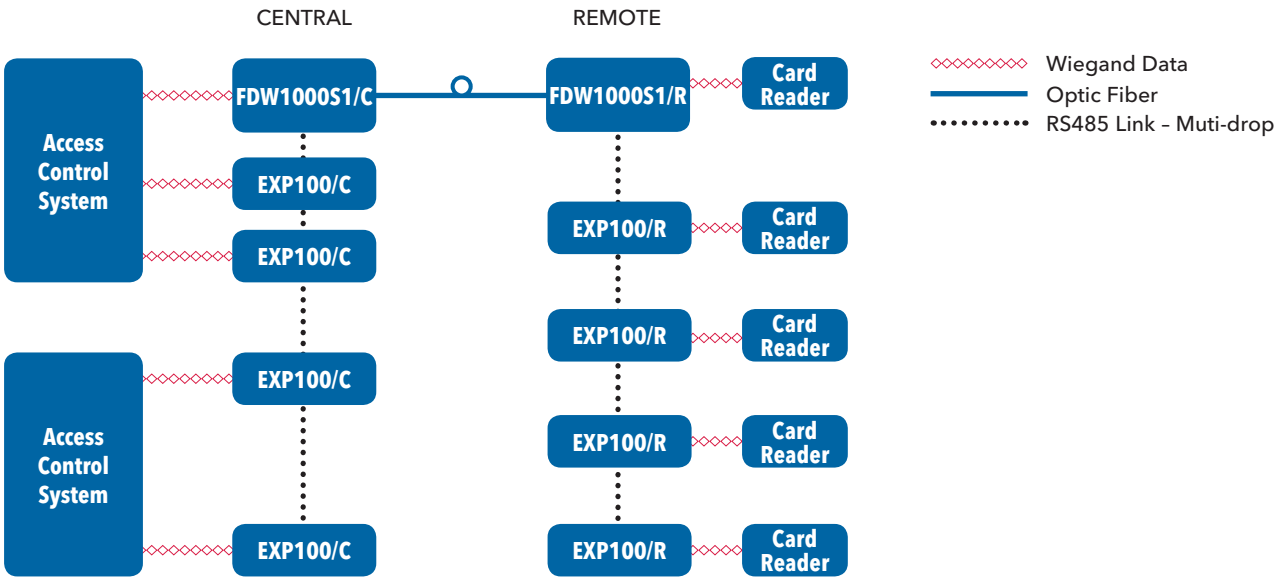

FIGURE 15 - EXP100 CENTRAL INTERFACE

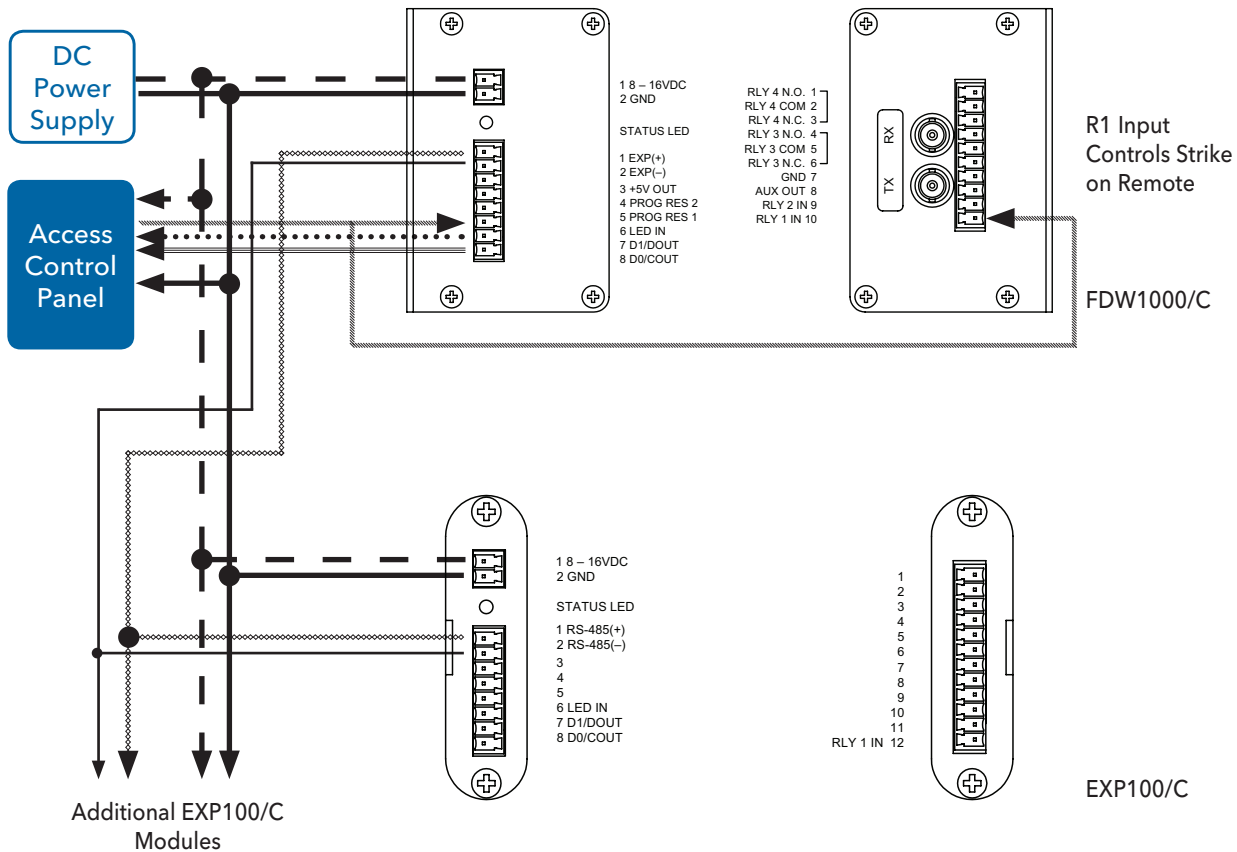
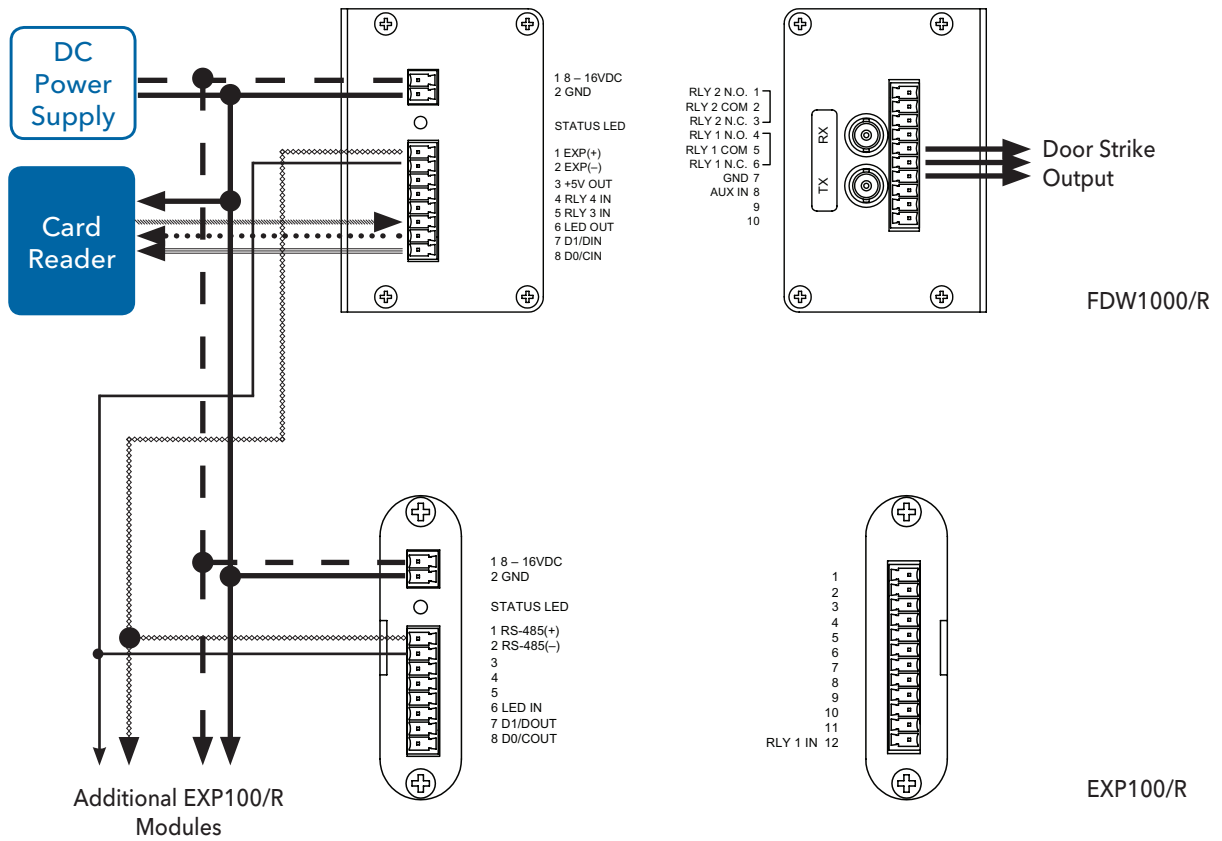

FIGURE 16 - EXP100 REMOTE INTERFACE



MECHANICAL INSTALLATION INSTRUCTIONS

FIGURE 17 - LED INDICATORS

	FDW1000/C	FDW1000/R
GRN FLASH	Unit is operating correctly and there is a valid communication channel between the Central and Remote units.	
RED	N/A	Remote unit is not receiving communication from the Central unit.
RED/GRN FLASH	Central unit is not receiving communication from the Remote unit.	N/A
OFF	Unit Powered Down / Electrical Problem	

INSTALLATION CONSIDERATIONS

This fiber-optic link is supplied as a Standalone module. Units should be installed in dry locations protected from extremes of temperature and humidity.

CAUTION: Take care not to press on any of the LEDs.

WARNING: Unit is to be used with a Listed Class 2 or LPS power supply.

IMPORTANT SAFEGUARDS:

A) Elevated Operating Ambient - If installed in a closed or multi-unit rack assembly, the operating ambient temperature of the rack environment may be greater than room ambient. Therefore, consideration should be given to installing the equipment in an environment compatible with the maximum ambient temperature (T_{ma}) specified by the manufacturer.

B) Reduced Air Flow - Installation of the equipment in a rack should be such that the amount of air flow required for safe operation of the equipment is not compromised.

FIGURE A

Dimensions are for a standard ComNet FDW1000 module

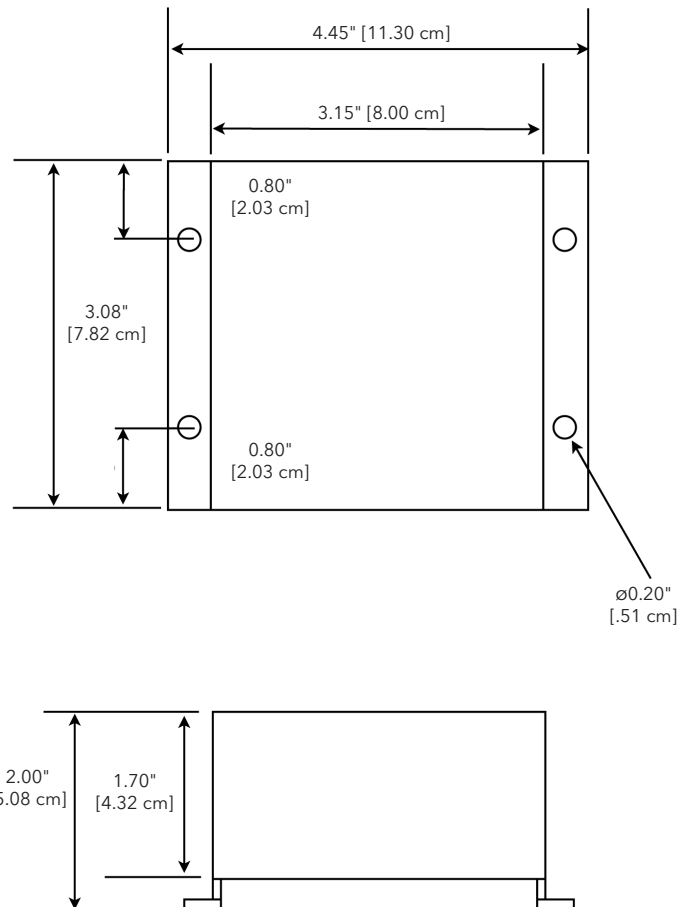

3 CORPORATE DRIVE | DANBURY, CT 06810 | USA
 T: 203.796.5300 | F: 203.796.5303 | TECH SUPPORT: 1.888.678.9427 | INFO@COMNET.NET
 8 TURNBERRY PARK ROAD | GILDERSOME | MORLEY | LEEDS, UK LS27 7LE
 T: +44 (0)113 307 6400 | F: +44 (0)113 253 7462 | INFO-EUROPE@COMNET.NET