



## STW4 Two way Monitoring Station Instructions

---

The STW4 is a 4 zone 2-way Audio surveillance monitoring station for use with all ETS STW1 series microphone / speakers. It can be used independently for monitoring live audio or with DVRs, tape recorders for recording and playback.

### **STW1 Mounting**

Locate the STW1 Microphone/Speaker near the area of interest. Do not mount the STW1 near air conditioning vents, light fixtures or electrical equipment. Try to keep the distance between the STW1 and the STW4 under 1,000 feet.

### **Cable Run**

Run a 22 gauge, 6 conductor shielded cable (1,000 feet maximum length) between the STW1s and the STW4 base station. Keep the cable away from AC power sources, light fixtures and electrical equipment. See connection diagram.

### **Adjusting the STW1 Microphone Gain**

On the back of the STW1, near the center of the board, is an adjustment pot labeled "Gain." Use a small flathead screwdriver and turn towards + or – for maximum clarity. If the sound at the amplifier is distorted, rotate towards the – mark (counter clockwise). If the sound is too low, rotate towards the + mark (clockwise). Be careful not to move the pot too far in either direction.

### **Setting the STW1 Jumpers**

The STW1 Microphone has jumper selectable treble boost and limiter circuits. The treble boost circuit emphasizes the high frequency sounds that the Microphone picks up. This is useful for improving the sound quality on slow speed tape recordings (VCR time-lapse recordings). The limiter circuit automatically keeps the STW1's output at a relatively constant level. This eliminates the need for the listener to reduce the volume control on the amplifier when sounds get louder.

**Note: Do not use the STW1's limiter circuit if you are using a tape recorder or other devices that use an AGC or limiter circuit.**

Recommended Jumper settings:

	Stand-alone Application	Tape Recorder Application
Limiter	"IN"	"OUT"
Treble Boost	"OUT"	"IN"

### **STW4 Base Station Controls**

After connections have been made, apply power to the unit and the system is ready to use. You should hear all 4STW1s audio on the STW4 base station Speaker. Adjust the main "Volume" knob to a comfortable level. You can set individual channel volumes by the pot under the channel LED.

### **Sending a message to the STW1s**

Select the channels you wish to send a message to (verify that your chosen channel's green LED lights are lit.

Then press and hold the "Push To Talk" button on the base station. The yellow LED light indicates that the base station microphone is sending audio to the selected STW1s.

Speak in the direction of the microphone opening. Release the "Push To Talk" button when you have finished your message. The yellow LED will go out.

If necessary, you can adjust the remote Speaker volume by turning the "Remote Volume" knob clockwise for louder sound and counter clockwise for softer sound.

**Audio connection to a recording device**

Connect the "Audio Out" jack to the recording device's "Audio In", using the supplied RCA cables. Connect the "Audio In" jack to the recording device's "Audio Out." Press and hold the Channel 1 button until the red "Recorder In" light comes on (about 2 seconds.)

**Headphones**

Plug headphones into the "Headphone" jack on the front panel of the STW4. Audio will be cut out on the base station speaker.

**Optional Call Switch**

If you have the "Call Switch" option, simply press the button on the STW1 to start a 1 second tone to the STW4. The called STW1 channel will flash until you press any channel button to acknowledge. To hear that channel's audio, press the button that corresponds to the flashing channel.

**Caution**

It may be against the law to install this microphone kit in certain environments. It may also be against the law to record conversations of the person(s) being monitored without their knowledge. It is the responsibility of the installation company and end-user to determine if the application of this product is legal. These laws vary from state to state. If you are not informed on these matters, consult a qualified attorney or contact the appropriate state agency. A sticker is provided with this kit for the applications where notification must be posted.

**Warranty**

All ETS products carry a one year parts and labor warranty. This warranty does not cover damages as a result of misuse, improper handling of the unit or exposure to extreme temperatures or moisture. At its discretion, ETS reserves the right to repair or replace this unit under the conditions of the warranty. If you experience problems with your equipment call ETS at: 505-888-3923 to obtain a return authorization number. Equipment requiring repair beyond the warranty period or units that have been damaged or are not covered under the warranty can be repaired by ETS for a minimal cost under most conditions.

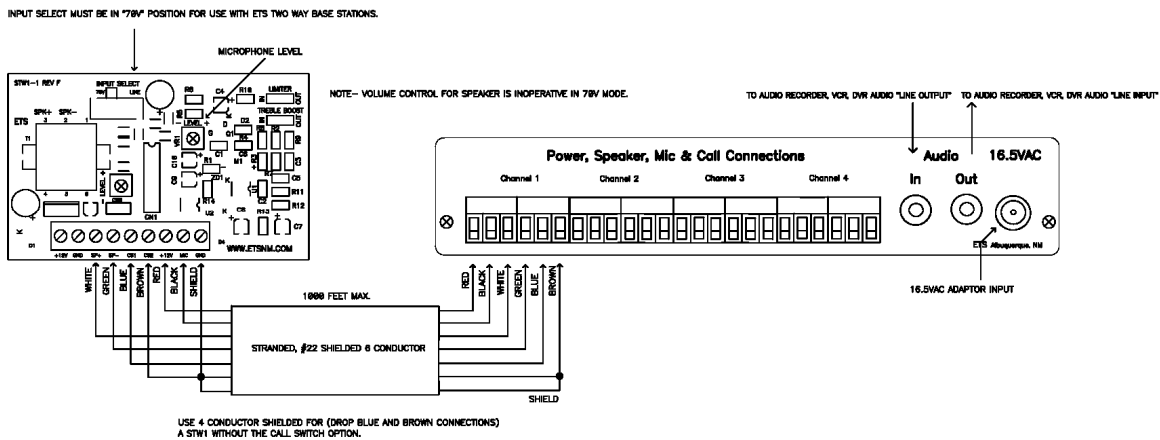

Made in the USA  
by  
**ETS Inc.**