

1" 3MP FA Fixed Lens with Manual Iris 25mm Short Wave IR F-1.4 C-Mount
Compatible with 1", 2/3", 1/2", 1/3" Cameras

SPECIFICATIONS

Focal Length	25mm	Optical Back Focal Distance	16.6 mm (In Air)
Maximum Relative Aperture	1:1.4	Flange Back	17.526 mm
Iris	F1.4 - 22	Operation Focus	Manual
Angular Field of View	29.0° x 21.9° (D 36.1°)	Operation Iris	Manual
Image Format	12.8 x 9.6 mm (Ø16 mm)	Operation Temperature	-10 °C ~ 50 °C / 14 °F ~ 122 °F
Minimum Object Distance	0.3m (From Front Vertex)	Mount	C-Mount (Adjustable Lens Position)
Optical Distortion	-2.2% at near -1.8% at far	Filter Size	35.5 mm P 0.5
TV Distortion	-0.5% at near -0.7% at far	Size, Weight	Ø 40 x 42.5(D) mm / 119g

DIMENSIONS

UNIT: mm

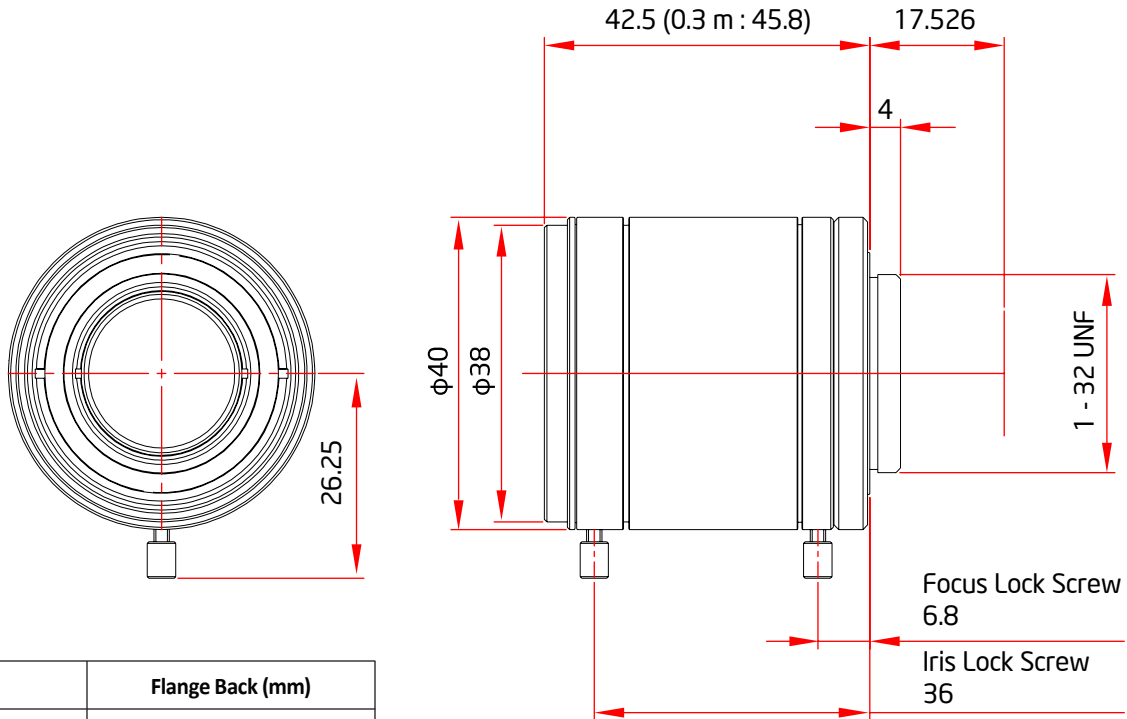

Wave (μm)	Flange Back (mm)
0.9	17.652
1.1	17.741
1.3	17.84
1.5	17.951
1.7	18.078