

Sarix® IME Indoor and Environmental Mini Domes

UP TO 3 MPX, WDR AND LOW-LIGHT PERFORMANCE, H.264, IK10, IP66

Product Features

- SureVision 3.0 Technology, Including:
 - 130dB Wide Dynamic Range (WDR)
 - Advanced Low-Light Performance, 0.05 lux
 - Anti-Bloom Technology
 - 3D Noise Filtering
 - Enhanced Tone Mapping
- Up to 3 Megapixel (MPx) Resolution
- Up to 60 Images per Second (ips)
- Autofocus Varifocal 3 ~ 9 mm or 9 ~ 22 mm Lens
- Power over Ethernet (PoE), IEEE 802.3af, 24 VAC, 12 VDC
- Built-in Analytics Suite
- Adaptive IR Illumination up to 30 Meters
- Up to 128 GB Edge Storage with SD Card

Sarix Enhanced Range with SureVision 3.0

Sarix® Enhanced (E) range cameras deliver high definition (HD) resolution, consistent color science, fast processing power, and simultaneous advanced low-light performance with wide dynamic range (WDR) and anti-bloom technologies. New advancements include 3D noise filtering, smooth response to illumination changes, and improved tone mapping to retain color accuracy and overall image contrast.

Designed to install quickly, the cameras include autofocus, motorized zoom, built-in analytics, and other advanced features needed for demanding security applications.

Camera

The **IME Series** contains an integrated varifocal MPx autofocus lens (3 ~ 9 mm or 9 ~ 22 mm). Form factors include indoor and outdoor domes. All models feature a sturdy design that is both vandal- and tamper-resistant. The environmental model features worry-free use in a wide range of environmental operating conditions.

Sarix Enhanced range cameras include four unique, advanced autofocus options: temperature change (every 10°C / 18°F), day/night transition, a daily autofocus routine, and manual autofocus. These benefits ensure clear, focused images regardless of the scene or environment. All autofocus options are available through the web UI.

Integrated and Adaptive IR Illumination is optionally available on all outdoor models.



- Compatible with Pelco and Third-Party Video Systems
- ONVIF Profile S and Profile G Conformant
- Full 3-Year Warranty and Support

Video

The **IME Series** supports two independently-configurable video streams in addition to a service video stream. The streams can be compressed in MJPEG and H.264 formats across several resolution configurations. The **IME Series** offers real-time video (60 fps) with full HD resolution (up to 3 MPx) using H.264 compression for optimized bandwidth and storage efficiency.

The streams can be configured to a variety of frame rates, bit rates, and group of pictures (GOP) structures for additional flexibility in bandwidth administration. In addition, streams can be encoded as constrained variable bit rate (CVBR) or constant bit rate (CBR).

Open and Integrated

Sarix Enhanced range cameras seamlessly connect to Pelco video management systems such as VideoXpert™, Endura® version 2.0 (or later), and Digital Sentry® version 7.3 (or later). **Sarix Enhanced** range cameras integrate with major third-party video management systems through the Pelco API, and other third-party software and systems through the ONVIF Profile S and Profile G standards.

Built-In Analytics

Analytics enhance the flexibility and performance of **Sarix Enhanced** range cameras. Eight behaviors are preloaded and included as standard features. These behaviors can be configured and enabled using a standard Web browser, and they are compatible with VideoXpert, Endura, or a third-party system that supports alarms using Pelco's API.

Convenient Power

Sarix Enhanced range cameras are designed with Power over Ethernet (PoE) 24 VAC and 12 VDC to reduce costs and simplify planning, wiring, and installation. PoE functionality works with PoE-enabled network switches or power injectors, eliminating the need for separate power supplies and cabling, and increasing camera fail safety through an uninterruptible power supply (UPS).

ANALYTICS

Sarix Enhanced range cameras includes eight user-configurable behaviors. The camera is capable of running up to two behaviors at the same time.

For each behavior, you can create several custom profiles that contain different camera settings. With these profiles, you can set up different scenarios for the behavior, which will automatically detect and trigger alarms when specific activity is detected.

Analytics are configured and enabled using a standard Web browser, and behavior alarms are compatible with VideoXpert or a third-party system that supports Pelco's API system.

Analytics behaviors can be scheduled to work during a certain time or condition. For example, during the day, a camera can be configured with Object Counting to count the number of people that enter a lobby door. At night, the operator can change the profile to Camera Sabotage to trigger an alarm if a camera is moved or obstructed. Available behaviors include:

- **Abandoned Object:** Detects objects placed within a defined zone and triggers an alarm if the object remains in the zone unattended. An airport terminal is a typical installation for this behavior. This behavior can also detect objects left behind at an ATM, signaling possible card skimming.
- **Intrusion Detection:** Detects and tracks objects that enter a scene and then triggers an alarm when the objects enter a user-defined zone. This behavior is primarily used in outdoor environments with light traffic to reduce the number of false alarms caused by environmental changes.
- **Camera Sabotage:** Detects contrast changes in the field of view. An alarm is triggered if the lens is obstructed by spray paint, a cloth, or a lens cap. Any unauthorized repositioning of the camera also triggers an alarm.
- **Wrong Direction:** Generates an alarm in a high traffic area when a person or object moves in a specified direction. Typical installations for this behavior include an airport gate or tunnel where cameras can detect objects moving in the opposite direction of the normal flow of traffic or an individual entering through an exit door.
- **Loitering Detection:** Identifies when people or vehicles remain in a defined zone too long. This behavior is effective in real-time notification of suspicious behavior around ATMs, stairwells, and school grounds.
- **Object Counting:** Counts the number of objects that cross a defined line. This behavior can be used to count the number of people at a store entrance/exit or inside a store where the traffic is light. This behavior is based on tracking and does not count people in a crowded setting.
- **Object Removal:** Triggers an alarm if an object is removed from a user-defined zone. This behavior is ideal for customers who want to detect the removal of high value objects, such as a painting from a wall or a statue from a pedestal.
- **Stopped Vehicle:** Detects vehicles stopped near a sensitive area longer than the user-defined time allows. This behavior is ideal for airport curbside drop-offs, parking enforcement, suspicious parking, traffic lane breakdowns, and vehicles waiting at gates.

TECHNICAL SPECIFICATIONS

COMPONENT FEATURES



VALUES IN PARENTHESES ARE INCHES; ALL OTHERS ARE CENTIMETERS.

		<p>Indoor/Vandal-Resistant, Surface Mount</p> <ul style="list-style-type: none"> • Meets IK10 (20J) • IP64 • Aluminum Base and Plastic Trim Ring • SE White 3, RAL 9003
		<p>Environmental/Vandal-Resistant, Surface Mount</p> <ul style="list-style-type: none"> • Attaches to 4S Electrical Box with Adapter • Meets IP66 • Meets Type 4X (with IMEEBAP adapter plate accessory) • Meets IK10 (20J) • Aluminum Construction • Telegrey 4, RAL 7047

CAMERA

Imaging Device	1/2.8-inch
Imager Type	CMOS
Imager Readout	Progressive scan
Highest Resolution	
3 MPx	2048 x 1536
2 MPx	1920 x 1080
1.3 MPx	1280 x 960
Signal-to-Noise Ratio	>60 dB
Electronic Shutter Range	1/20000 sec (or faster) to 2 sec
Wide Dynamic Range	130 dB
White Balance Range	2,000° to 10,000°K
Sensitivity 3 ~ 9 mm	f/1.3; 2,850°K; SNR >20 dB
Color (33 ms)	0.050 lux
Color (500 ms)	0.005 lux
Mono (33 ms)	0.010 lux
Mono (500 ms)	0.001 lux
Mono (IR on)	0.000 lux
Sensitivity 9 ~ 22mm	f/1.6; 2,850°K; SNR >20 dB
Color (33 ms)	0.200 lux
Color (500 ms)	0.010 lux
Mono (33 ms)	0.100 lux
Mono (500 ms)	0.0025 lux
Mono (IR on)	0.000 lux
Day/Night Capabilities	Yes
Mechanical IR Cut Filter	Yes, (ON/OFF/AUTO selectable), with different set points on lux
Adaptive IR Illumination	850nm wavelength, maximum distance of 30 meters (100 feet) IR illumination at 0 lux
SD Card Support	Up to 128 GB
SDHC/SDXC Cards Supported	Yes

LENS

Lens Type	Built-in; varifocal
Focal Length	f/1.3, 3 ~ 9 mm, f/1.6, 9 ~ 22 mm
Focus	Autofocus, motorized
Zoom	Remote
Auto Iris Type	DC drive P-iris lens
Field of View in Degrees	

Lens	Focal Length	Resolution	Mode	Angle of View	
				Horizontal	Vertical
3 ~ 9 mm	Wide	3 MPx	4:3	100°	74°
	Tele			39°	29°
	Wide	1.3 MPx and 2 MPx	16:9	93°	52°
	Tele			37°	21°
9 ~ 22mm	Wide	3 MPx	4:3	33°	24°
	Tele			14°	10°
	Wide	1.3 MPx and 2 MPx	16:9	36°	20°
	Tele			15°	9°

TECHNICAL SPECIFICATIONS

AUDIO

Streaming Input/Output	Bidirectional: full or half duplex Line level/external microphone input; Single-ended, stereo, 1 Vp-p max. signal level
Compression	G.711 PCM 8 bit, 8 kHz mono at 64 kbit/s

MECHANICAL

Dome Attenuation Clear	f/0.0 light loss
Pan/Tilt Adjustment	Manual
Pan	355°
Tilt	75°
Rotation	340°

PHYSICAL

Weight	Shipping
Indoor, Surface Mount	1020 gm (2.25 lb)
Environmental, Surface Mount	1020 gm (2.25 lb)
Product Box Dimensions (approximate)	6.75 x 6.75 x 6.75 in.

ENVIRONMENTAL

Operating Temperature	
Indoor/Vandal-Resistant	-10° to 55°C (14° to 131°F) [†]
Environmental	-40° to 55°C (-40° to 131°F) [†]
Start-up Temperature	
Indoor	-10°C (14°F)
Environmental	With heater, -40°C (-40°F)
Storage Temperature	
Indoor and Environmental	-40° to 60°C (-40° to 140°F)
Operating Humidity	
Indoor/Vandal-Resistant	10 to 90%, RH noncondensing
Environmental	0 to 90%, RH noncondensing
Storage Humidity	20 to 80%, RH noncondensing
Impact Resistance	IK10 (20J) per IEC 62262

ELECTRICAL

Network Port	RJ-45 connector for 100Base-TX Auto MDI/MDI-X
Cable Type	Cat5 or better for 100Base-TX
Input Power	PoE (IEEE 802.3af, Class 3), 24 VAC, 12 VDC
Power Consumption	Up to 12 W nominal
Current Consumption	330 mA @ POE; 0.5 mA @ 24 VAC; 1A @ 12 VDC
Local Storage	SD, SDHC, SDXC
Alarm	Detects open or closed alarm state
Input	5 VDC maximum, 0.5 mA maximum
Relay Output	±350V VDC maximum, ±130 mA maximum

NETWORK

Supported Protocols	TCP/IP, UDP/IP (Unicast, Multicast IGMP), UPnP, DNS, DHCP, RTP, RTSP, NTP, IPv4, IPv6, SNMP v2c/v3, QoS, HTTP, HTTPS, SSH, SSL, SMTP, FTP, ARP, ICMP, and 802.1x (EAP)
Users	
Unicast	Up to 20 simultaneous users depending on the resolution settings
Multicast	Unlimited users H.264
Security Access	Password protected
Software Interface	Web browser view and setup

VIDEO

Video Streams	Independently configurable primary and secondary streams plus service stream
Available Resolutions	Two configurable streams as follows:

Camera Model	Aspect Ratio	MPx	Width	Height
3 MPx	4:3	3.0	2048	1536
		1.8	1600	1200
		1.2	1280	960
		0.5	800	600
		0.3	704	480
		0.3 (480p)	640	480
		0.07	320	240
3 MPx and 2 MPx	16:9	2.0 (1080p)	1920	1080
		0.9 (720p)	1280	720
		0.6	1024	576
		0.5	960	544
		0.3	800	448
		0.2	640	360
		0.06	320	192

Frame Rate	Up to 60, 50, 30, 25, 20, 16, 15, 12, 10, 8, 7, 6, 5, 4, 3, 2, 1 (depending on the coding, resolution, and WDR stream configuration)
Video Encoding	H.264 High, Main, or Base profiles; and MJPEG
Bit Rate Control	Constrained variable bit rate (CVBR) and constant bit rate (CBR)
Service Stream	JPEG stream; the JPEGs will be the same resolution as the primary stream

TECHNICAL SPECIFICATIONS

MINIMUM SYSTEM REQUIREMENTS

Processor	Intel® Core™ i3 processor, 2.4 GHz
Operating System	Microsoft® Windows® 7 (32- and 64-bit), or DirectX®11, Windows XP Service Pack 3 with DirectX 9.0c; or Mac® OS X 10.4 (or later)
Memory	4 GB RAM
Network Interface	100 megabits (or greater)
Monitor	Minimum of 1024 x 768 resolution, 16- or 32-bit pixel color resolution
Web Browser	Internet Explorer® 8.0 (or later), Google Chrome™ (51 or later) or Mozilla® Firefox® 3.5 (or later); Internet Explorer 8.0 (or later) is recommended for configuring analytics
Media Player	Pelco Media Player for Windows 7, XP, or Vista; or QuickTime 7.6.4 for Mac OS X 10.4 (or later)

ANALYTICS

Required Systems for Analytics

Open API The Pelco API can transmit behavior alarm data to third-party applications, available at pdn.pelco.com Integration

INTEGRATION

Pelco System Integration	VideoXpert; Endura 2.0 (or later); Digital Sentry 7.3 (or later) DX4700/DX4800
Open API	Pelco API or ONVIF Profile S and Profile G
Mobile Application	Integrated with Pelco Mobile Application

SOFTWARE FEATURES

- Multilingual menus in user interface: Arabic, English, French, Italian, German, Korean, Spanish, Portuguese, Russian, Simplified Chinese, Turkish
- 16 window blanks, configurable in size
- Password protection
- Snapshot with same resolution as highest stream configured
- Text overlays for camera name, time, date, or custom text
- Image overlays

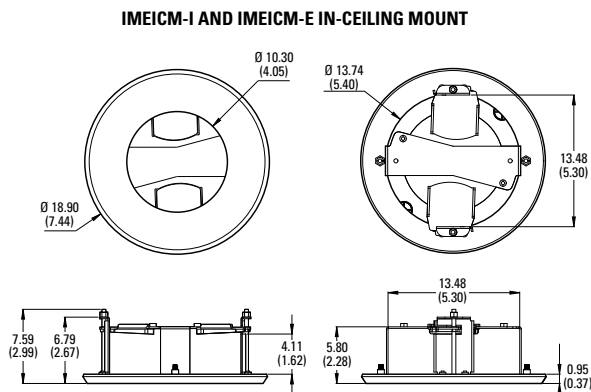

CERTIFICATIONS/RATINGS*

- CE (Class A)
- FCC (Class A)
- ICES-003 (Class A)
- UL/cUL Listed
- UL/IEC 60950-22
- KC
- RCM
- Meets Type 4X, IP66 rating (Environmental models), and IK10 (indoor models)
- ONVIF Profile S and Profile G Conformant

*At the time of this publication, certifications are pending. Consult the factory or www.pelco.com for the current status of certifications.

RECOMMENDED MOUNTS

WMVE-SR	Wall mount, 1.5 in., NPT, outdoor, RAL 7047
WMVE-SW	Wall mount, 1.5 in., NPT, indoor, RAL 9003
IMEICM-E	Environmental in-ceiling mount, RAL 7047
IMEICM-I	Indoor in-ceiling mount, RAL 9003
IMEPMB-I	Wall mount bracket, light duty, indoor, RAL 9003

OPTIONAL ACCESSORIES

PA101	Pole adapter for use with WMVE-SR pendant mount
IMEPM-I	Indoor pendant mount, RAL 9003
IMEPM-E	Environmental pendant mount, RAL 7047
IMEEBAP-I	Indoor electrical box adapter
IMEEBAP-E	Environmental electrical box adapter and Type 4X adapter
IMELD2-OI	Smoke lower dome (indoor)
IMELD2-OE	Smoke lower dome (environmental)

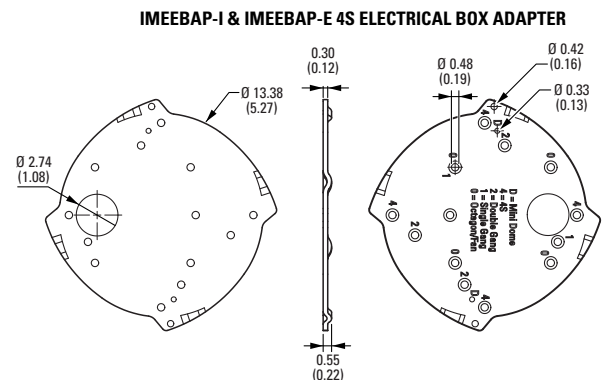
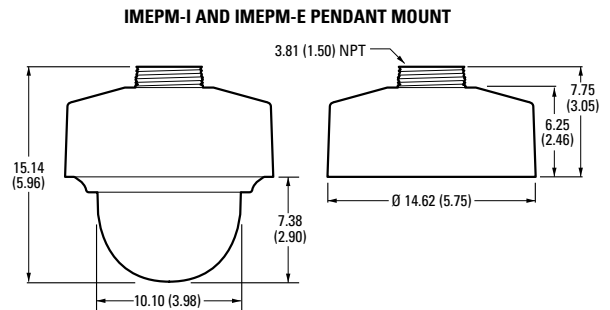

TECHNICAL SPECIFICATIONS

MODELS*

Back Box	Resolution	Model Number	Lens	Description
Surface	1.3 MPx	IME129-1ES	3 ~ 9 mm	Sarix Enhanced Environmental Dome
	1.3 MPx	IME129-1IS	3 ~ 9 mm	Sarix Enhanced Indoor Dome
	1.3 MPx	IME129-1RS	3 ~ 9 mm	Sarix Enhanced Environment IR Dome
	1.3 MPx	IME122-1ES	9 ~ 22 mm	Sarix Enhanced Environmental Dome
	2 MPx	IME229-1ES	3 ~ 9 mm	Sarix Enhanced Environmental Dome
	2 MPx	IME229-1IS	3 ~ 9 mm	Sarix Enhanced Indoor Dome
	2 MPx	IME229-1RS	3 ~ 9 mm	Sarix Enhanced Environment IR Dome
	2 MPx	IME222-1ES	9 ~ 22 mm	Sarix Enhanced Environmental Dome
	2 MPx	IME222-1IS	9 ~ 22 mm	Sarix Enhanced Indoor Dome
	2 MPx	IME222-1ES	9 ~ 22 mm	Sarix Enhanced Environmental IR Dome
	3 MPx	IME329-1RS	3 ~ 9 mm	Sarix Enhanced Environmental Dome
	3 MPx	IME329-1IS	3 ~ 9 mm	Sarix Enhanced Indoor Dome
	3 MPx	IME329-1RS	3 ~ 9 mm	Sarix Enhanced Environment IR Dome
	3 MPx	IME322-1ES	9 ~ 22 mm	Sarix Enhanced Environmental Dome
	3 MPx	IME322-1IS	9 ~ 22 mm	Sarix Enhanced Indoor Dome
	3 MPx	IME322-1RS	9 ~ 22 mm	Sarix Enhanced Environmental IR Dome

**System options contain a back box/mount, camera, and clear dome.

