



### Features

- 1/4" 1Megapixel progressive scan CMOS
- H.264 & MJPEG dual-stream encoding
- Max 25/30fps@720P(1280×720)
- DWDR, Day/Night(ICR), 3DNR, AWB, AGC, BLC
- Multiple network monitoring: Web viewer, CMS(DSS/PSS) & DMSS
- 3.6mm fixed lens (2.8mm,6mm optional)
- Max. IR LEDs Length 20m
- IP66, PoE



# IPC-HDW1000S

## Technical Specifications

<b>Model</b>	<b>IPC-HDW1000S</b>	
<b>Camera</b>		
Image Sensor	1/4" 1Megapixel progressive scan CMOS	
Effective Pixels	1280(H)x720(V)	
Scanning System	Progressive	
Electronic Shutter Speed	Auto/Manual 1/3(4)~1/10000	
Min. Illumination	0.01Lux/F1.8( Color), 0Lux/F1.8 (IR on)	
S/N Ratio	More than 50dB	
Video Output	N/A	
<b>Camera Features</b>		
Max. IR LEDs Length	20m	
Day/Night	Auto(ICR) / Color / B/W	
Backlight Compensation	BLC /HLC /DWDR	
White Balance	Auto/Manual	
Gain Control	Auto/Manual	
Noise Reduction	3D	
Privacy Masking	Up to 4 areas	
<b>Lens</b>		
Focal Length	3.6mm (2.8mm,6mm optional)	
Max Aperture	F1.8(F1.8/F1.8)	
Focus Control	Manual	
Angle of View	H: 75.5°(89°/48.5°)	
Lens Type	Fixed lens	
Mount Type	Board-in Type	
<b>Video</b>		
Compression	H.264B/H.264/ MJPEG	
Resolution	720P(1280×720)/D1(704×576/704×480) /CIF(352×288/352×240)	
Frame Rate	Main Stream	720P(1 ~ 25/30fps)
	Sub Stream	D1/CIF(1 ~ 25/30fps)
Bit Rate	H.264H: 16K ~ 8Mbps	
<b>Audio</b>		
Compression	N/A	
Interface	N/A	
<b>Network</b>		
Ethernet	RJ-45 (10/100Base-T)	
Wi-Fi	N/A	
Protocol	IPv4/IPv6, HTTP, HTTPS, TCP/IP, UDP, UPnP, ICMP, IGMP, RTSP, RTP, SMTP, NTP, DHCP, DNS, PPPOE, DDNS, FTP, IP Filter, QoS	
Compatibility	ONVIF, CGI	
Max. User Access	20 users	
Smart Phone	iPhone, iPad, Android, Windows Phone	



# IPC-HDW1000S

Auxiliary Interface	
Memory Slot	N/A
RS485	N/A
Alarm	N/A
PIR Sensor Range	N/A
General	
Power Supply	DC12V, PoE (802.3af)
Power Consumption	Max 4.5W
Working Environment	-30°C~+60°C, Less than 95%RH
Ingress Protection	IP66
Vandal Resistance	N/A
Dimensions	Φ113.6mm x 85.8mm
Weight	0.29Kg

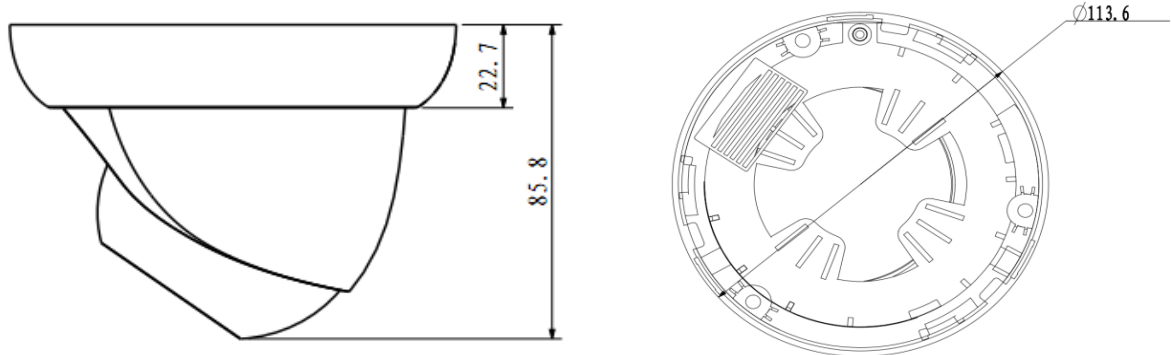
## Dimensions (mm)

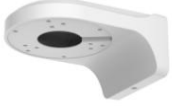
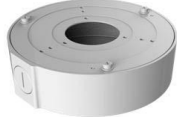

## Accessory (optional)

		
PFB200W	PFA130	PFA122

### Winic Technologies USA Inc.

42 Central avenue, Farmingdale, New York

11735 Tel: +631-396-0800

Fax: +631-396-0805

Email:sales@winictech.com

www.winictech.com

\*Design and specifications are subject to change without notice.