

FLAT LCD DISPLAY MOUNT MODEL



WB-30 WALL MOUNT BRACKET

1. Dimension of Bracket

This mount is designed for LCD VESA® Standard Screens with a screen size from 10" to 23" and weight up to 15Kg. It has a twin arm design that allows for full flexibility when mounting your screen - it can mount the screen flat to the wall or extend out to up to 370mm from the wall. There are three swivel points - one at the wall for 180°, one in the middle of 240° and one at the screen of 240° - this makes it possible to mount your screen in the most convenient of

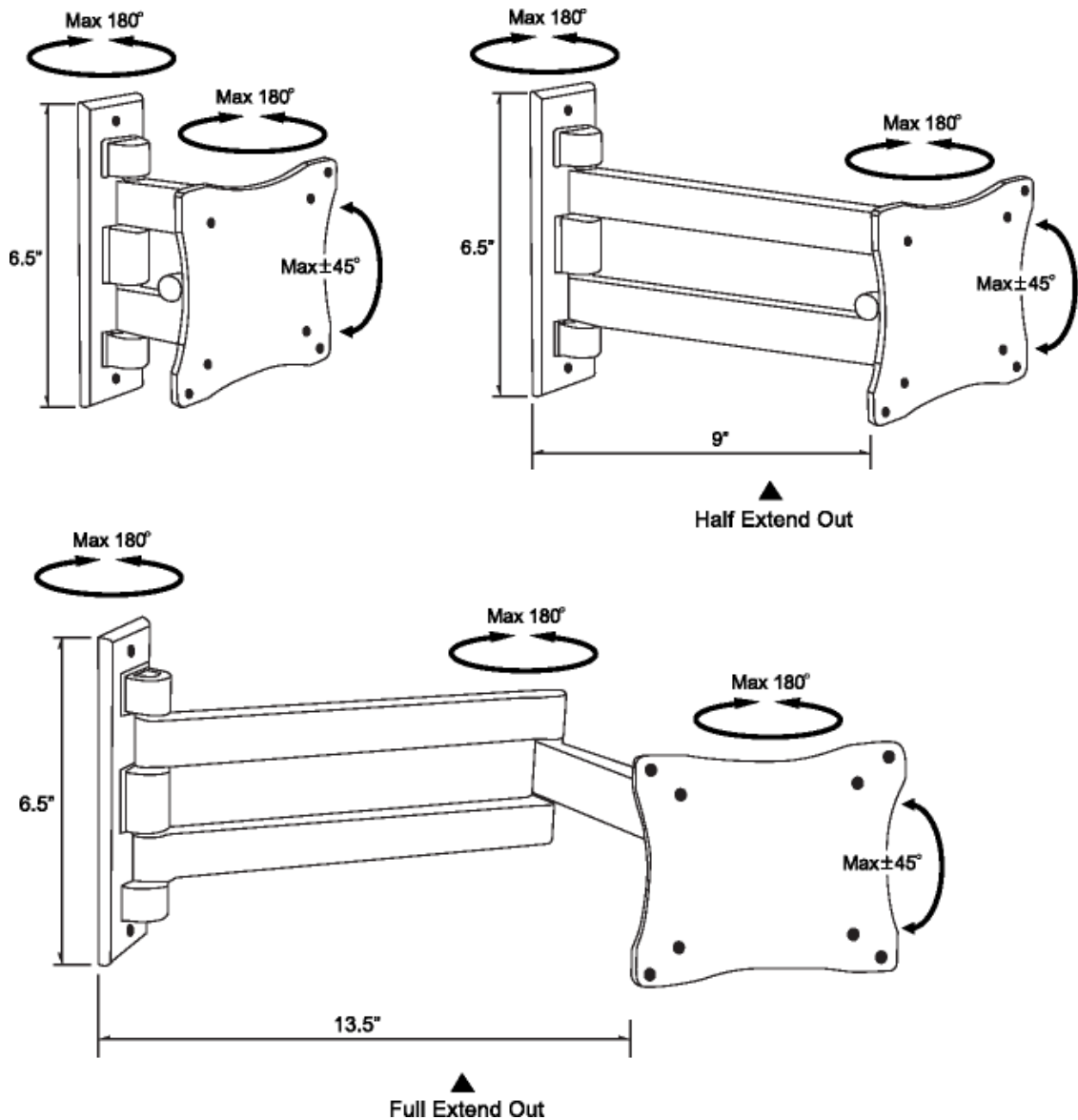

2. Installation

