

# TROVE™ Installation Guide

## Versatile Access Power and Integration Enclosures

### Trove2AM2

- Trove2 enclosure with Altronix/AMAG backplane (TAM2)

### TAM2

- Altronix/AMAG backplane only

#### Overview:

Trove2AM2 accommodates various combinations of AMAG boards with or without Altronix power supplies and accessories for access systems.

#### Specifications:

##### Trove2AM2

- Trove2 enclosure with TAM2 Altronix/AMAG backplane.
- Includes: tamper switch, cam lock, lock nuts and mounting hardware.
- 16 Gauge grey enclosure with ample knockouts for convenient access.
- Enclosure Dimensions (H x W x D):**  
27.25" x 21.75" x 6.5" (692.2mm x 552.5mm x 165.1mm).

##### TAM2

- TAM2 Altronix/AMAG backplane.
- 16 Gauge backplane.
- Includes mounting hardware.
- Dimensions (H x W x D):**  
25.375" x 19.375" x 0.3125" (644.6mm x 492.1mm x 7.9mm).



#### Backplane Accommodates a Combination of the Following:

- Two (2) AL400ULXB2, AL600ULXB, AL1012ULXB, AL1024ULXB2, eFlow4NB, eFlow6NB, eFlow102NB, or eFlow104NB.
- One ACM4(CB), ACM8(CB), MOM5, PD4UL(CB), PD8UL(CB), PDS8(CB), VR6.
- M2150 2DC, M2150 4DC, M2150 AC24/4, M2150 2DBC, M2150 4DBC, or M2150 8DBC.

#### Installation Instructions for Trove2:

1. Remove backplane from enclosure prior to mounting (do not discard hardware).
2. Mark and predrill holes in the wall to line up with the top keyholes in the enclosure. Install the upper fasteners and screws in the wall with the screw heads protruding. Place the enclosure's upper keyholes over the screws; level and secure. Mark the position of the lower holes. Remove the enclosure. Drill the lower holes and install the fasteners. Place the enclosure's upper keyholes over the upper screws. Install the lower screws and make sure to tighten all screws (*Enclosure Dimensions, pg. 8*).
3. Mount included UL Listed tamper switch (Honeywell Model 112 or equivalent) in desired location, opposite hinge. Slide the tamper switch bracket onto the edge of the enclosure approximately 2" from the right side (*Fig. 1, pg. 1*). Connect tamper switch wiring to the Access Control Panel input or the appropriate UL Listed reporting device. To activate alarm signal open the door of the enclosure.
4. Mount Altronix/AMAG boards to backplane, refer to *pages 2-4*.

#### Hardware:

	Metal or Nylon Standoff
	5/16" Pan Head Screw
	Lock Nut

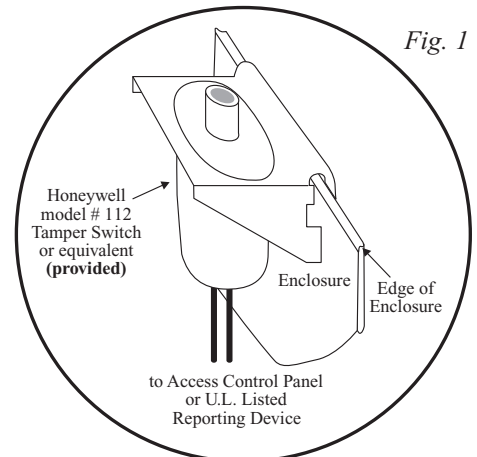

## **TAM2: Configuration of Altronix Power Supply and/or Sub-Assembly Boards and AMAG Boards AMAG M2150 2DC and M2150 2DBC**

1. Fasten standoffs (provided) to pems that match the hole pattern for Altronix Power Supply/Chargers or Altronix Sub-Assembly boards (*Fig. 2, 2a, pg. 2*). Fasten metal standoffs in the correct locations to provide proper grounding, see below (*Fig. 2, pg. 2*).
2. Mount boards to standoffs utilizing 5/16" pan head screws (provided) (*Fig. 2, pg. 2*).
3. Align the AMAG boards on the backplane to match the boards' mounting holes with pems provided.
4. Fasten standoffs (provided) to pems that match the hole pattern for AMAG M2150 2DC and 2150 2DBC boards.
5. Mount AMAG boards to standoffs utilizing 5/16" pan head screws (provided) (*Fig. 2, pg. 2*).

**Note:** AMAG M2150 2DC boards have specific markings.

Please orient boards in the appropriate position according to the *Fig. 2* below.

6. Fasten backplane to Trove2 enclosure utilizing lock nuts (provided).

*Fig. 2*

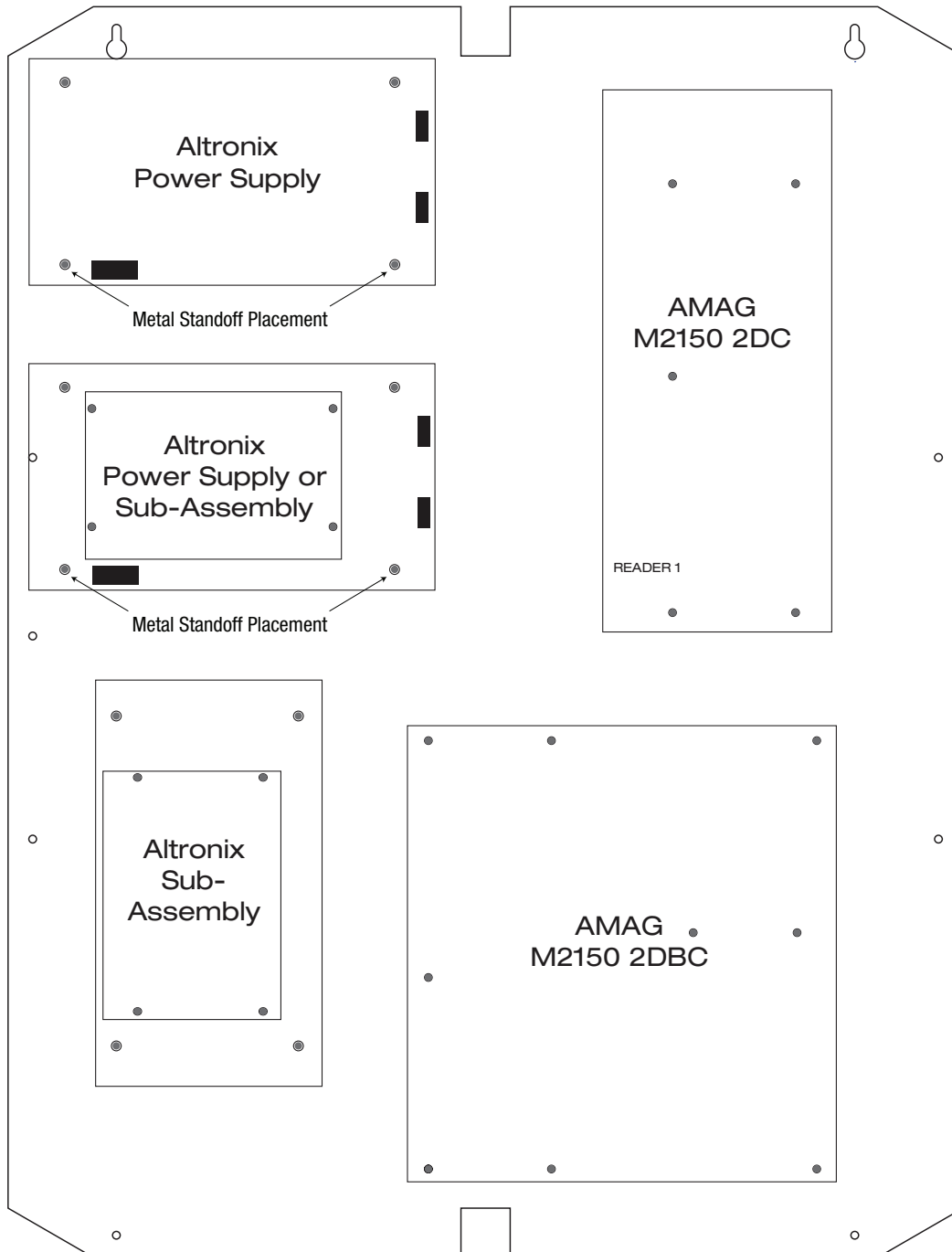

*Fig. 2a*

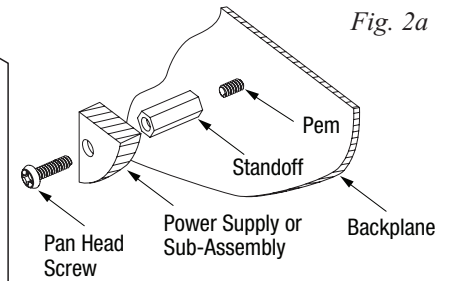

**TAM2: Configuration of Altronix Power Supply and/or Sub-Assembly Boards and AMAG Boards AMAG M2150 4DC, M2150 4DBC, and M2150 8DBC**

1. Fasten standoffs (provided) to pems that match the hole pattern for Altronix Power Supply/Chargers or Altronix Sub-Assembly boards (*Fig. 3, 3a, pg. 3*). Fasten metal standoffs in the correct locations to provide proper grounding, see below (*Fig. 3, pg. 3*).
2. Mount boards to standoffs utilizing 5/16" pan head screws (provided) (*Fig. 3, pg. 3*).
3. Align the AMAG boards on the backplane to match the boards' mounting holes with pems provided.
4. Fasten standoffs (provided) to pems that match the hole pattern for AMAG M2150 4DC, M2150 4DBC, and M2150 8DBC boards.
5. Mount AMAG boards to standoffs utilizing 5/16" pan head screws (provided) (*Fig. 3, pg. 3*).  
**Note:** AMAG M2150 4DBC and M2150 8DBC boards have specific markings.  
 Please orient boards in the appropriate position according to the *Fig. 3* below.
6. Fasten backplane to Trove2 enclosure utilizing lock nuts (provided).

*Fig. 3*

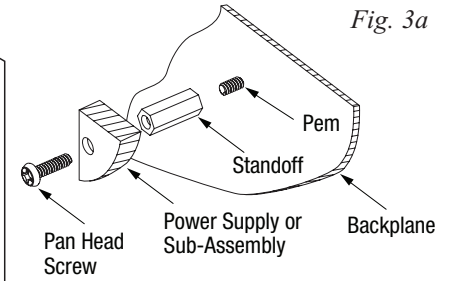
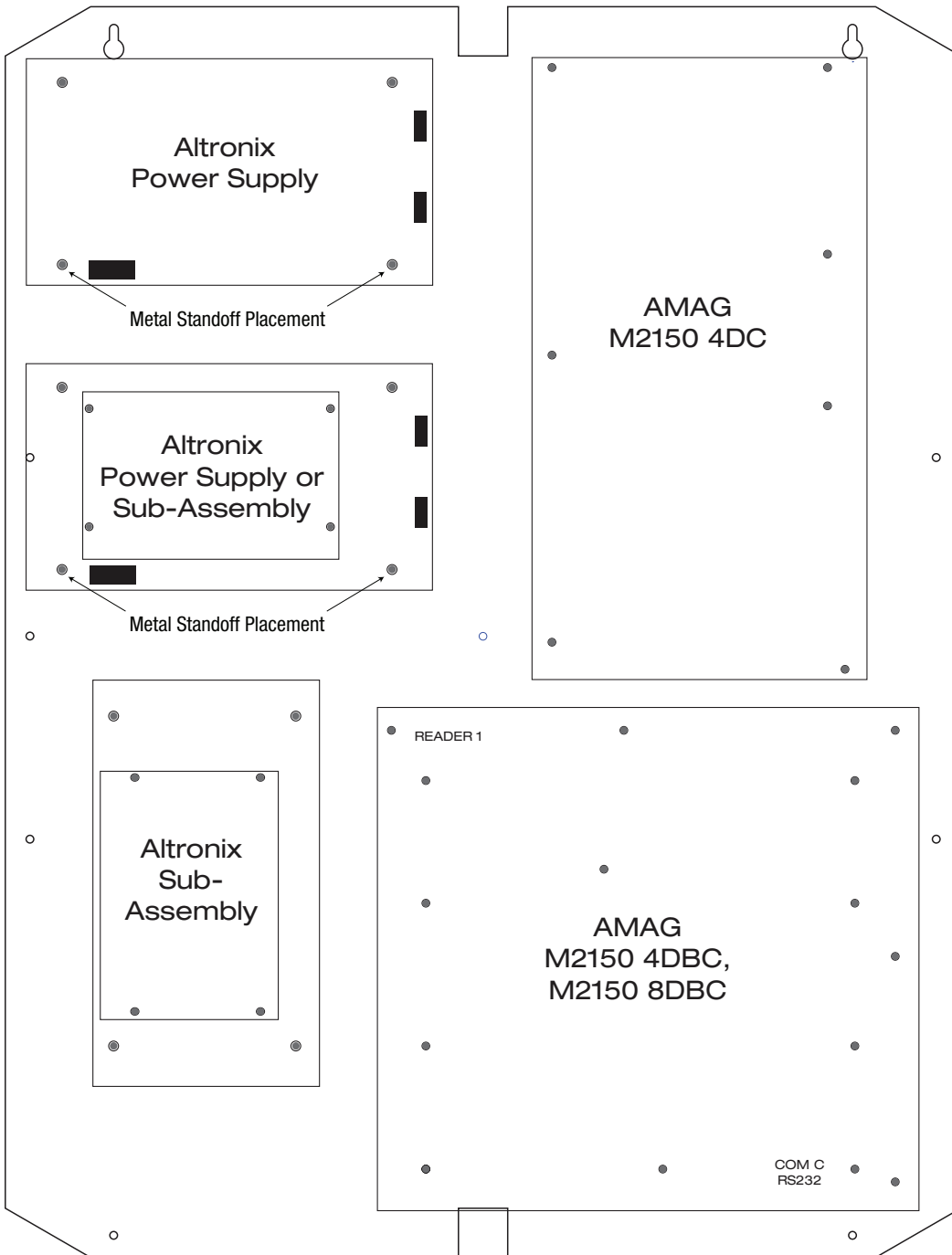
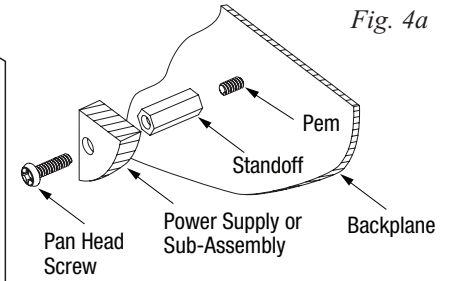
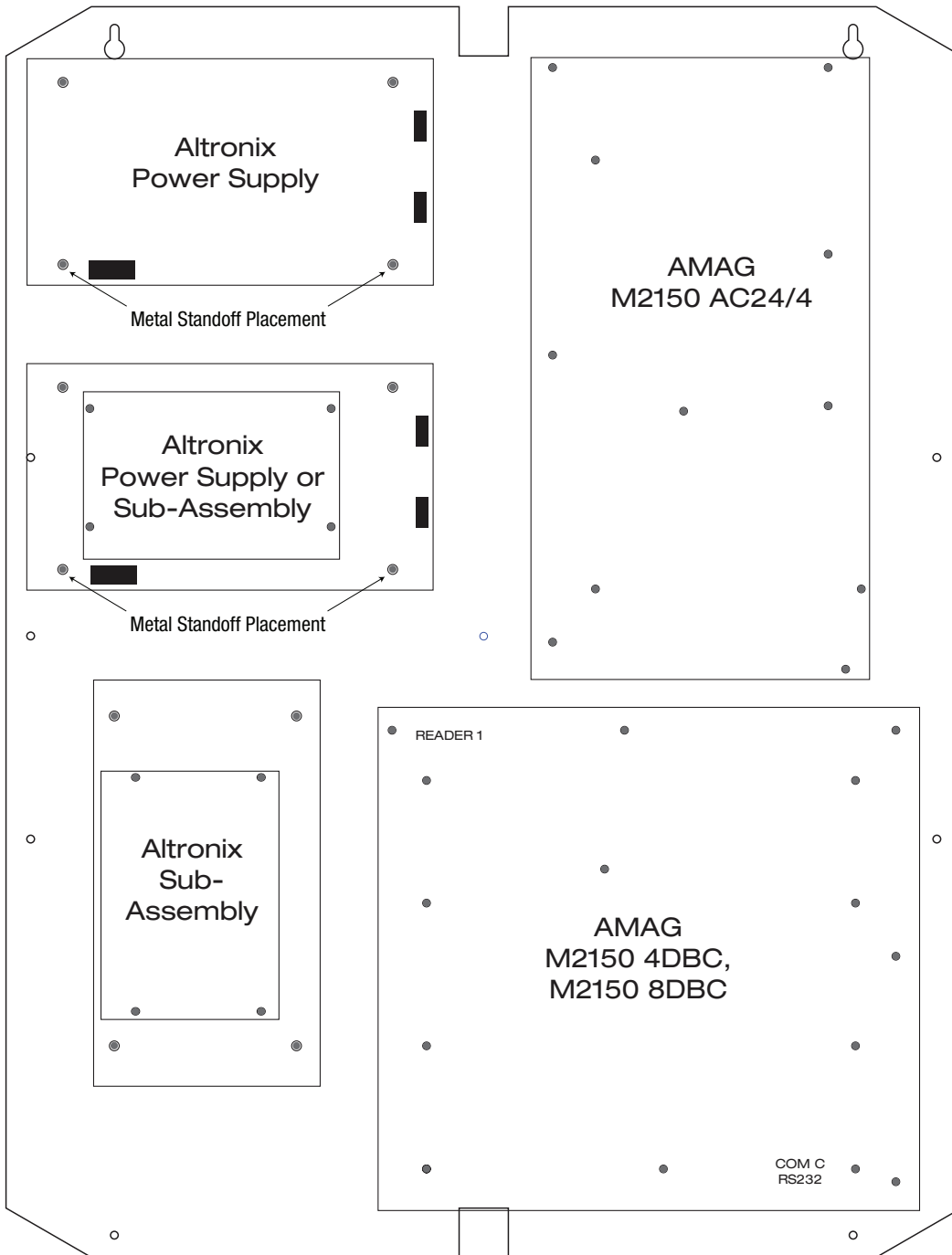

*Fig. 3a*

**TAM2: Configuration of Altronix Power Supply and/or Sub-Assembly Boards and AMAG Boards AMAG M2150 AC24/4, M2150 4DBC, and M2150 8DBC**

1. Fasten standoffs (provided) to pems that match the hole pattern for Altronix Power Supply/Chargers or Altronix Sub-Assembly boards (Fig. 4, 4a, pg. 4). Fasten metal standoffs in the correct locations to provide proper grounding, see below (Fig. 4, pg. 4).
2. Mount boards to standoffs utilizing 5/16" pan head screws (provided) (Fig. 4, pg. 4).
3. Align the AMAG boards on the backplane to match the boards' mounting holes with pems provided.
4. Fasten standoffs (provided) to pems that match the hole pattern for AMAG M2150 AC24/4, M2150 4DBC, and M2150 8DBC boards.
5. Mount AMAG boards to standoffs utilizing 5/16" pan head screws (provided) (Fig. 4, pg. 4).  
**Note:** AMAG M2150 4DBC and M2150 8DBC boards have specific markings.  
 Please orient boards in the appropriate position according to the Fig. 4 below.
6. Fasten backplane to Trove2 enclosure utilizing lock nuts (provided).

Fig. 4



**Notes:**

**Notes:**

**TAM2 Dimensions (H x W x D):**  
 25.375" x 19.375" x 0.3125" (644.6mm x 492.1mm x 7.9mm)

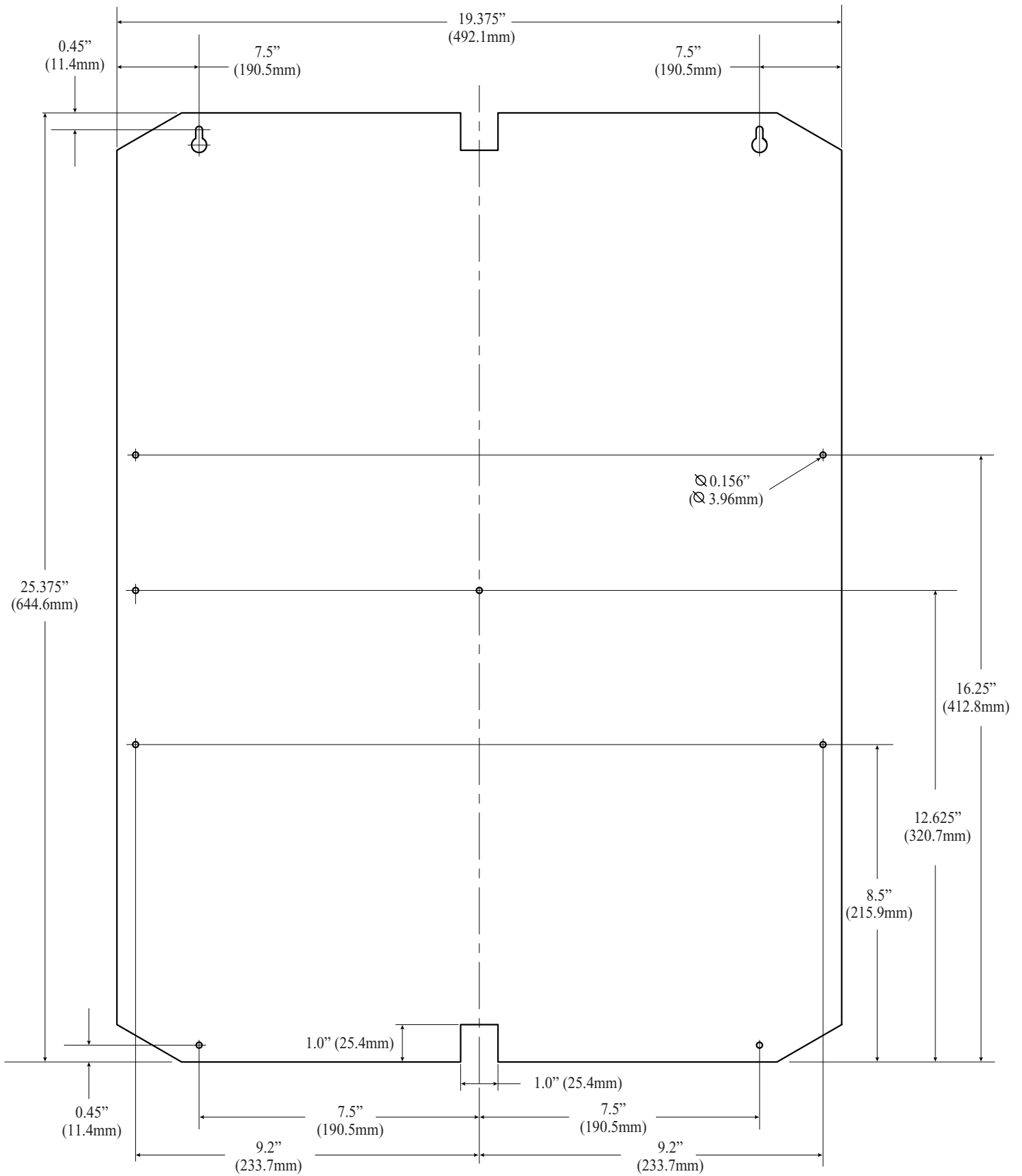

**Trove2 Enclosure Dimensions (H x W x D approximate):**  
 27.25" x 21.75" x 6.5" (692.15mm x 552.5mm x 165.1mm)

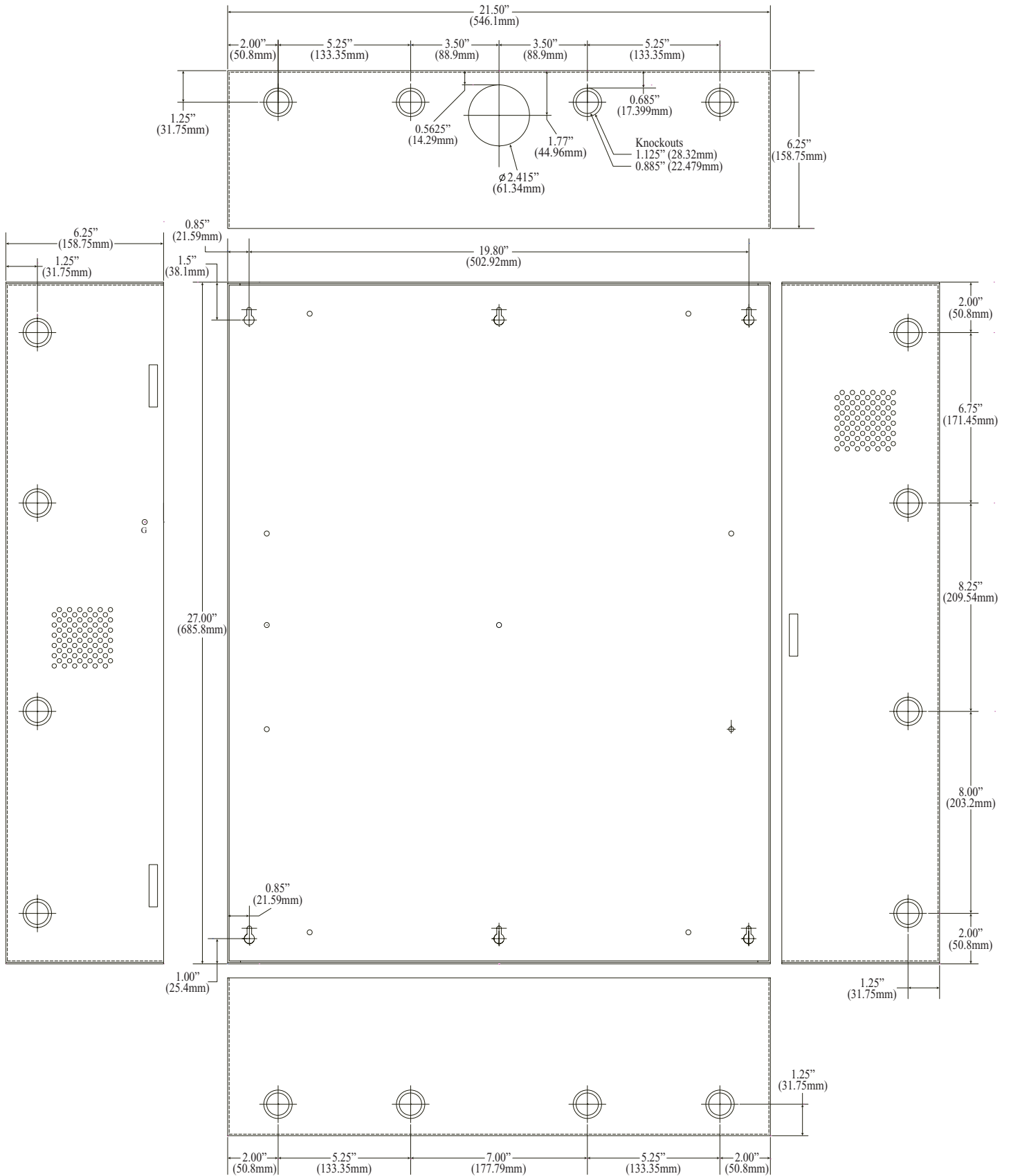

Altronix is not responsible for any typographical errors.

140 58th Street, Brooklyn, New York 11220 USA | phone: 718-567-8181 | fax: 718-567-9056  
 web site: www.altronix.com | e-mail: info@altronix.com | Made in U.S.A.

ITrove2AM2  
 - 8 -

J31Q

