

DIVAR IP 6000 1U

DIP-6040-00N, DIP-6042-4HD



BOSCH

Table of contents

1	Safety precaution	5
1.1	General safety precautions	5
1.2	Electrical safety precautions	6
1.3	ESD precautions	7
1.4	Operating precautions	7
1.5	Important notices	8
1.6	FCC and ICES compliance	8
2	System overview	9
2.1	Chassis features	9
2.2	Chassis components	9
2.2.1	Chassis	9
2.2.2	Backplane	10
2.2.3	Fans	10
2.2.4	Mounting rails	10
2.2.5	Power supply	10
2.2.6	Air shroud	10
2.3	System interface	10
2.3.1	Control panel buttons	11
2.3.2	Control panel LEDs	11
2.3.3	Drive carrier LEDs	12
2.3.4	Power supply LEDs and overheat indicators	12
2.3.5	Overheating	13
3	Chassis setup and maintenance	14
3.1	Removing the chassis cover	14
3.2	Installing hard drives	14
3.2.1	Removing hard drive trays	14
3.2.2	Installing a hard drive	15
3.3	Installing a DVD-ROM or floppy drive	17
3.4	Replacing the internal transcoder device	17
3.5	Installing the motherboard	18
3.6	Installing the air shroud	18
3.7	System fans	19
3.8	Power supply	20
3.8.1	Power supply failure	20
4	Rack installation	22
4.1	Unpacking the system	22
4.2	Preparing for setup	22
4.2.1	Choosing a setup location	22
4.2.2	Rack precautions	22
4.2.3	General system precautions	23
4.2.4	Rack mounting considerations	23
4.3	Rack mounting instructions	23
4.3.1	Identifying the sections of the rack rails	24
4.3.2	Installing the inner rails	24
4.3.3	Assembling the outer rails	25
4.3.4	Installing the outer rails to the rack	25
4.3.5	Installing the chassis into the rack	26

4.3.6	Installing the chassis into a Telco rack	27
4.4	Turning on the system	27
5	Appendix	28
5.1	Motherboard	28
5.1.1	Motherboard layout	28
5.1.2	Motherboard component overview	29
5.1.3	Motherboard features	31
5.1.4	Block diagram	33
5.2	Chipset overview	33
5.3	PC health monitoring	34
5.4	Power configuration settings	34
5.5	Power supply	35
5.6	Super I/O	35
5.7	iSCSI support	35
5.8	Overview of the Nuvoton BMC controller	36
5.9	RAID disaster recovery	36
5.9.1	Multiple disks failed - theory	37
5.9.2	Multiple disks failed - practice	42
5.9.3	Foreign configuration disk appears in the Windows GUI after booting	45
5.9.4	MegaCLI Commandline Utility	46

1 Safety precaution

Observe the safety precautions in this chapter.

1.1 General safety precautions

Follow these rules to ensure general safety:

- Keep the area around the system clean and free of clutter.
- Place the chassis top cover and any system components that have been removed away from the system or on a table so that they won't accidentally be stepped on.
- While working on the system, do not wear loose clothing such as neckties and unbuttoned shirt sleeves, which can come into contact with electrical circuits or be pulled into a cooling fan.
- Remove any jewelry or metal objects from your body, which are excellent metal conductors that can create short circuits and harm you if they come into contact with printed circuit boards or areas where power is present.
- After accessing the inside of the system, close the system back up and secure it to the rack unit after ensuring that all connections have been made.
- The system weighs approximately 38.5 lbs. (17.5 kg) when fully loaded. When lifting the system, two people at either end should lift slowly with their feet spread out to distribute the weight. Always keep your back straight and lift with your legs.

Warning!



Interruption of mains supply:

Voltage is applied as soon as the mains plug is inserted into the mains socket.

However, for devices with a mains switch, the device is only ready for operation when the mains switch (ON/OFF) is in the ON position. When the mains plug is pulled out of the socket, the supply of power to the device is completely interrupted.

Warning!



Removing the housing:

To avoid electric shock, the housing must only be removed by qualified service personnel. Before removing the housing, the plug must always be removed from the mains socket and remain disconnected while the housing is removed. Servicing must only be carried out by qualified service personnel. The user must not carry out any repairs.

Warning!



Power cable and AC adapter:

When installing the product, use the provided or designated connection cables, power cables and AC adapters. Using any other cables and adapters could cause a malfunction or a fire. Electrical Appliance and Material Safety Law prohibits the use of UL or CSA-certified cables (that have UL/CSA shown on the code) for any other electrical devices.

**Warning!**

Lithium battery:

Batteries that have been inserted wrongly can cause an explosion. Always replace empty batteries with batteries of the same type or a similar type recommended by the manufacturer. Handle used batteries carefully. Do not damage the battery in any way. A damaged battery may release hazardous materials into the environment.

Dispose of empty batteries according to the manufacturer's instructions.

**Warning!**

Handling of lead solder materials used in this product may expose you to lead, a chemical known to the State of California to cause birth defects and other reproductive harm.

**Notice!**

Electrostatically sensitive device:

To avoid electrostatic discharges, the CMOS/MOSFET protection measures must be carried out correctly.

When handling electrostatically sensitive printed circuits, grounded anti-static wrist bands must be worn and the ESD safety precautions observed.

**Notice!**

Installation should only be carried out by qualified customer service personnel in accordance with the applicable electrical regulations.

**Disposal**

Your Bosch product has been developed and manufactured using high-quality materials and components that can be reused.

This symbol means that electronic and electrical devices that have reached the end of their working life must be disposed of separately from household waste.

In the EU, separate collecting systems are already in place for used electrical and electronic products. Please dispose of these devices at your local communal waste collection point or at a recycling center.

1.2

Electrical safety precautions

Basic electrical safety precautions should be followed to protect you from harm and the system from damage:

- Be aware of the locations of the power on/off switch on the chassis as well as the room's emergency power-off switch, disconnection switch or electrical outlet. If an electrical accident occurs, you can then quickly remove power from the system.
- Do not work alone when working with high voltage components.
- Power should always be disconnected from the system when removing or installing main system components, such as the motherboard or memory modules. When disconnecting power, you should first turn off the system and then unplug the power cords from all the power supply modules in the system.
- When working around exposed electrical circuits, another person who is familiar with the power-off controls should be nearby to switch off the power if necessary.

- Use only one hand when working with powered-on electrical equipment. This is to avoid making a complete circuit, which will cause electrical shock. Use extreme caution when using metal tools, which can easily damage any electrical components or circuit boards they come into contact with.
- The power supply power cords must include a grounding plug and must be plugged into grounded electrical outlets. The unit has more than one power supply cord. Disconnect both power supply cords before servicing to avoid electrical shock.
- Mainboard replaceable soldered-in fuses: Self-resetting PTC (Positive Temperature Coefficient) fuses on the mainboard must be replaced by trained service technicians only. The new fuse must be the same or equivalent as the one replaced. Contact technical support for details and support.

**Caution!**

Mainboard Battery: There is a danger of explosion if the onboard battery is installed upside down, which will reverse its polarities. This battery must be replaced only with the same or an equivalent type recommended by the manufacturer (CR2032). Dispose of used batteries according to the manufacturer's instructions.

**Caution!**

DVD-ROM Laser: This system comes without a DVD-ROM drive but if added: To prevent direct exposure to the laser beam and hazardous radiation exposure, do not open the enclosure or use the unit in any unconventional way.

1.3

ESD precautions

Electrostatic Discharge (ESD) is generated by two objects with different electrical charges coming into contact with each other. An electrical discharge is created to neutralize this difference, which can damage electronic components and printed circuit boards. The following measures are generally sufficient to neutralize this difference before contact is made to protect your equipment from ESD:

- Do not use mats designed to decrease electrostatic discharge as protection from electrical shock. Instead, use rubber mats that have been specifically designed as electrical insulators.
- Use a grounded wrist strap designed to prevent static discharge.
- Keep all components and printed circuit boards (PCBs) in their antistatic bags until ready for use.
- Touch a grounded metal object before removing the board from the antistatic bag.
- Do not let components or printed circuit boards come into contact with your clothing, which may retain a charge even if you are wearing a wrist strap.
- Handle a board by its edges only. Do not touch its components, peripheral chips, memory modules or contacts.
- When handling chips or modules, avoid touching their pins.
- Put the mainboard and peripherals back into their antistatic bags when not in use.
- For grounding purposes, make sure your computer chassis provides excellent conductivity between the power supply, the case, the mounting fasteners and the mainboard.

1.4

Operating precautions

The chassis cover must be in place when the system is operating to assure proper cooling. Out of warranty damage to the system can occur if this practice is not strictly followed.

Note:

Please handle used batteries carefully. Do not damage the battery in any way. A damaged battery may release hazardous materials into the environment. Do not discard a used battery in the garbage or a public landfill. Please comply with the regulations set up by your local hazardous waste management agency to dispose of your used battery properly.

1.5**Important notices**

Accessories - Do not place this unit on an unstable stand, tripod, bracket, or mount. The unit may fall, causing serious injury and/or serious damage to the unit. Use only with the cart, stand, tripod, bracket, or table specified by the manufacturer. When a cart is used, use caution and care when moving the cart/apparatus combination to avoid injury from tip-over. Quick stops, excessive force, or uneven surfaces may cause the cart/unit combination to overturn. Mount the unit per the manufacturer's instructions.

1.6**FCC and ICES compliance**

(only for U.S.A. and Canada)

This equipment has been tested and found to comply with the limits for a Class A digital device pursuant to Part 15 of the FCC Rules. These limits are designed to provide reasonable protection against harmful interference when the equipment is operated in a commercial environment. This equipment generates, uses, and can radiate radio frequency energy and, if not installed and used in accordance with the manufacturer's instruction manual, may cause harmful interference with radio communications. Operation of this equipment in a residential area is likely to cause harmful interference, in which case you will be required to correct the interference at your own expense.

2 System overview

DIVAR IP 6000 is an affordable, simple and reliable all-in-one recording management solution for network surveillance systems of up to 64 cameras. Powered by VRM (Video Recording Manager) software, the system is an intelligent IP storage device that eliminates the need for separate NVR (Network Video Recorder) server and storage hardware.

The 1U rack mount unit combines advanced recording management and state-of-the-art iSCSI storage into a single cost-effective, plug and play IP recording appliance for IT-minded customers seeking for a state-of-the-art “second generation” NVR recording solution.

The DIVAR IP 6000 1U chassis features a unique and highly-optimized design. The chassis is equipped with high efficiency power supply.

High performance fans provide ample optimized cooling for memory modules. Hot-swap drive bays offer maximum storage capacity in a 1U form factor.

DIVAR IP 6000 features:

- Instant real time access to video
View high quality HD video despite low or limited bandwidth connections. Dynamic Transcoding technology ensures that you can view your video immediately – anytime, anywhere.
- Remote viewing
DIVAR IP 6000 comes with our advanced Video Client for remote viewing. Video Client is a Windows PC application for live viewing and playback including Configuration Manager. Configuration Manager allows the settings of the DIVAR IP 6000 be configured. A stand-alone archive player will allow archive playback and authentication without any other workstation software.

For information on supported hardware, see the datasheet for DIVAR IP 6000 in the Bosch Online Product Catalog.

2.1 Chassis features

The DIVAR IP 6000 1U high performance chassis includes the following features:

- CPU
The chassis supports a Dual-core Xeon processor.
- Hard Drives
The chassis features 4 slots for SATA drives. These drives are hot swappable. Once setup correctly, these drives can be removed without turning off the unit. In addition, these drives support SES2 (SAS/SATA).
- Other Features
Other onboard features are included to promote system health. These include various 4 cooling fans, a convenient power switch, reset button, and 5 LED indicators.

2.2 Chassis components

This chapter describes the most common components included with your chassis. For more information, see the installation instructions detailed later in this manual.

2.2.1 Chassis

The chassis includes 1 slim CD-ROM bay and 4 hard drive bays. The chassis accepts a 1U backplane, 4 fans and 2 power supplies.

2.2.2 Backplane

Each chassis comes with a 1U backplane. The backplane accepts SAS/SATA or SCSI hard drives.



Warning!

Use caution when servicing and working around the backplane. Hazardous voltage or energy is present on the backplane when the system is operating. Do not touch the backplane with any metal objects and make sure no ribbon cables touch the backplane.

2.2.3 Fans

The chassis supports 4 system fans that are powered from the motherboard. These fans are 1U high and are powered by 3-pin connectors.

2.2.4 Mounting rails

The unit can be placed in a rack for secure storage and use. To setup your rack, follow the step-by-step instructions included in this manual.

2.2.5 Power supply

Each chassis model includes 2 high-efficiency power supplies (redundant). In the unlikely event your power supply fails, replacement is simple and can be accomplished without tools.

2.2.6 Air shroud

Air shrouds are shields, usually plastic, which conduct the airflow directly to where it is needed. Always use the air shroud included with your chassis.

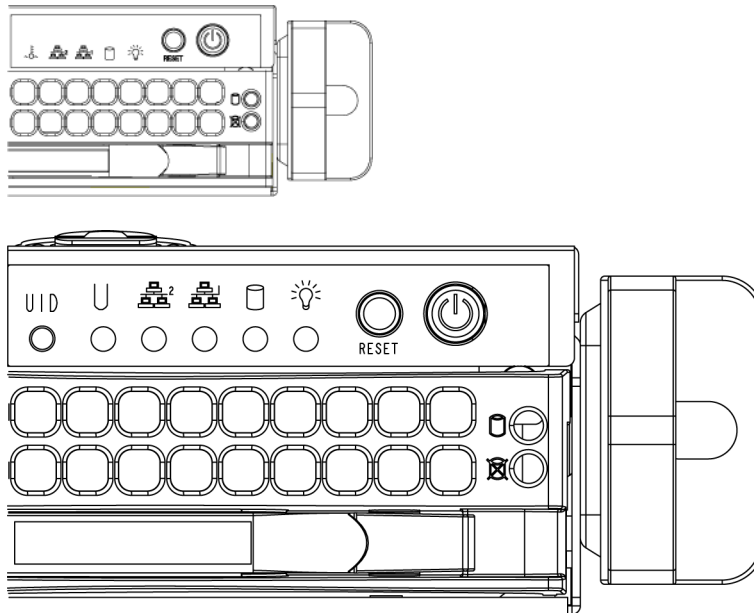

2.3 System interface

There are several LEDs on the front and rear of the chassis. The LEDs show the over-all status of the system and the activity and health of specific components.

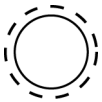

2.3.1 Control panel buttons

The chassis includes two or three push-buttons located on the front panel: a reset button, a power on/off button, and a UID button.

-  **Reset:** The reset button is used to reboot the system.
-  **Power:** The main power switch is used to apply or remove power from the power supply to the server system. Turning off system power with this button removes the main power but keeps standby power supplied to the system. **Therefore, you must unplug system before servicing.**





2.3.2 Control panel LEDs

The control panel located on the front of the chassis has up to 5 LEDs. These LEDs provide critical information related to different parts of the system. This section explains what each LED indicates when illuminated and any action that may be required.

-  **Universal Information LED:** The Universal Information LED is used to indicate fan failure, power failure, overheat condition, or to identify the unit within a large rack installation. The feature requires a motherboard that supports the Universal Information LED.

Universal Information LED States	
Fast blinking red (1x/sec)	Fan failure
Solid red	CPU overheat Note: Can be caused by cables obstructing the airflow in the system or the ambient room temperature being too warm.
Slow blinking red (1x/4 sec)	Power failure
Solid blue	Local UID button depressed
Blinking blue	IPMI-activated UID
Note: Deactivating the UID LED must be performed in the same way it was activated. If the UID LED was activated via IPMI, you can only turn the LED off via IPMI and not with the UID button.	

-  **Overheat/fan fail:** A flashing LED indicates a fan failure.
 When continuously on (not flashing) the LED indicates an overheat condition, which may be caused by cables obstructing the airflow in the system or the ambient room temperature being too warm. Check the routing of the cables and make sure all fans are present and operating normally. You should also check to make sure that the chassis covers are installed. Finally, verify that the heat sinks are installed properly.
 This LED will remain flashing or on as long as the fan failure/overheat condition exists.

-  **NiC2:** A flashing LED indicates network activity on GLAN2.
-  **NiC1:** A flashing LED indicates network activity on GLAN1.
-  **HDD:** A flashing LED indicates IDE channel activity in the SAS/SATA drive, SCSI drive, and/or DVD-ROM drive activity.
-  **Power:** Indicates power is being supplied to the system's power supply units. This LED should normally be illuminated when the system is operating.

2.3.3

Drive carrier LEDs

Your chassis uses SAS/SATA.

SAS/SATA drives

Each SAS/SATA drive carrier has two LEDs.

- **Green:** Each Serial ATA drive carrier has a green LED. When illuminated, this green LED (on the front of the SATA drive carrier) indicates drive activity. A connection to the SATA backplane enables this LED to blink on and off when that particular drive is being accessed.
- **Red:** The red LED indicates a SAS/SATA drive failure. If one of the SAS/SATA drives fail, you should be notified by your system management software.

2.3.4

Power supply LEDs and overheat indicators

This chassis provides several options which may include hot-swappable, cold-swappable, and redundant power supplies. Some power supplies include an LED in the rear with the following definitions:

450 W and 650 W power supplies

450 W and 650 W power supply LEDs	
Solid green	Power supply is on.
Solid amber	The power supply is plugged in and turned off, or the system is off but in an abnormal state.
Blinking amber	Power supply temperature has reached to 63° C. The system automatically turns off when the power supply temperature reaches 70° C and restarts when the power supply temperature is below 60° C.

All other power supplies

All other power supply LEDs	
Solid green	Power supply is on.
Solid amber	The power supply is plugged in and turned off, or the system is off but in an abnormal state.

2.3.5

Overheating

The section lists actions that should be taken in the unlikely event the server overheats.

Overheat temperature setting

Some backplanes allow the overheat temperature to be set at 45, 50, or 55 by changing a jumper setting.

If the server overheats, do the following:

1. Use the LEDs to determine the nature of the overheating condition.
2. Confirm that the chassis covers are installed properly.
3. Check the routing of the cables and make sure all fans are present and operating normally.
4. Verify that the heatsinks are installed properly.

3 Chassis setup and maintenance

This chapter covers the steps required to install components and perform maintenance on the chassis.



Caution!

Review the warnings and precautions listed in the manual before setting up or servicing this chassis.

3.1 Removing the chassis cover

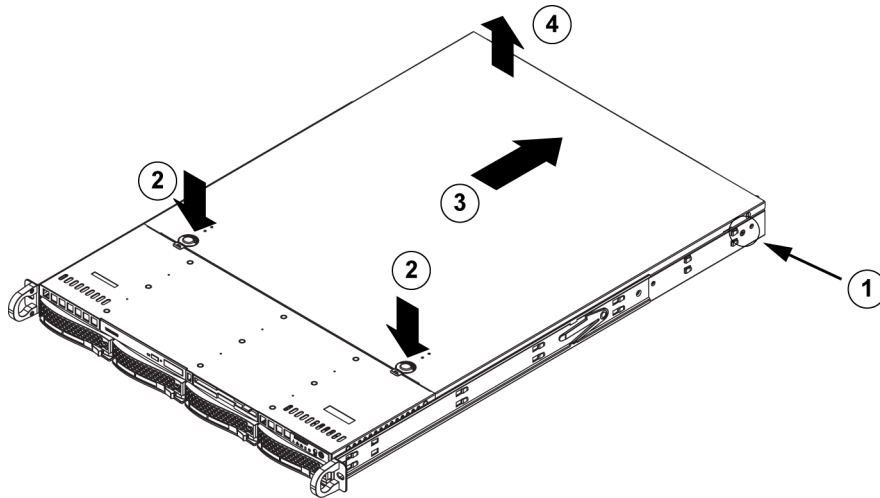

To remove the chassis cover:

1. Remove the two screws on each side of the cover, which secure the cover to the chassis.
2. Press the release tabs to remove the cover from the locked position. Press both tabs at the same time.
3. Once the top cover is released from the locked position, slide the cover toward the rear of the chassis.
4. Lift the cover off the chassis.



Notice!

Except for short periods of time, do NOT operate the server without the cover in place. The chassis cover must be in place to allow proper airflow and prevent overheating.

3.2 Installing hard drives

This chapter describes the removing and installing of hard drives.

3.2.1 Removing hard drive trays

The drives are mounted in drive carriers to simplify their installation and removal from the chassis. These carriers also help promote proper airflow for the drive bays.

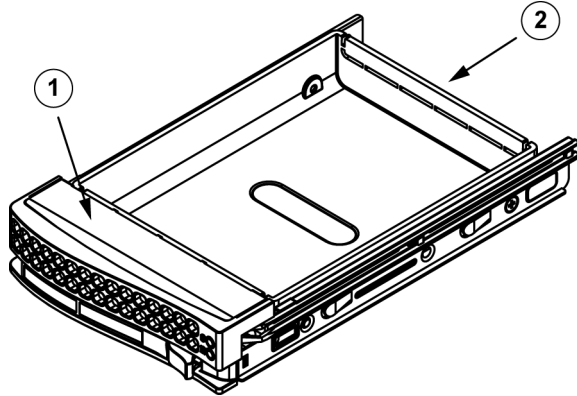

1	Drive carrier
2	Dummy drive

To remove hard drive trays from the chassis:

1. Press the release button on the drive carrier. This extends the drive carrier handle.

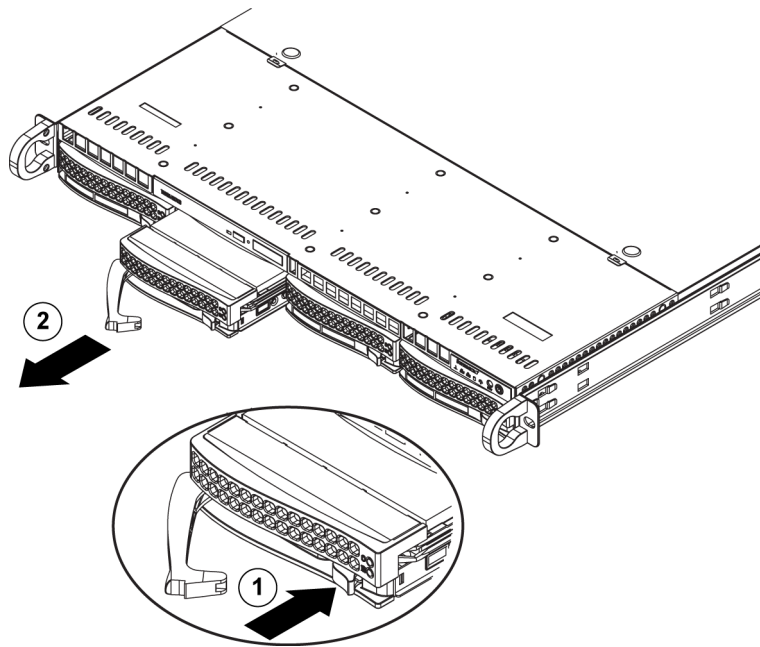

2. Use the handle to pull the drive out of the chassis.



Notice!

Except for short periods of time (swapping hard drives), do not operate the unit with the hard drives removed from the bays.

3.2.2

Installing a hard drive

The drives are mounted in drive carriers.

To install a hard drive to the hard drive carrier:

1. Remove the screws securing the dummy drive to the carrier.

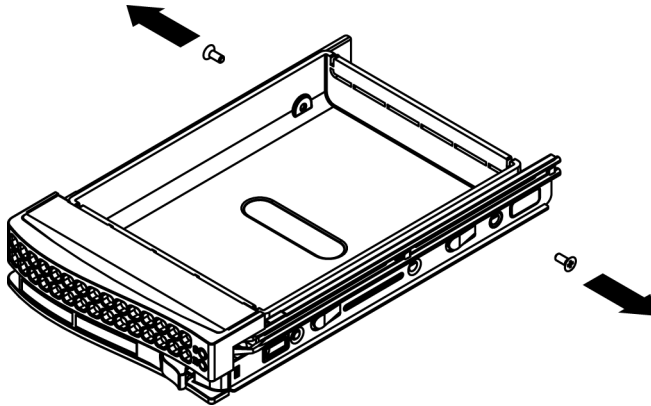

2. Remove the dummy drive from the carrier.
3. Install a new drive into the carrier with the printed circuit board side facing down so that the mounting holes align with those in the carrier.
4. Secure the hard drive by tightening all 6 screws.

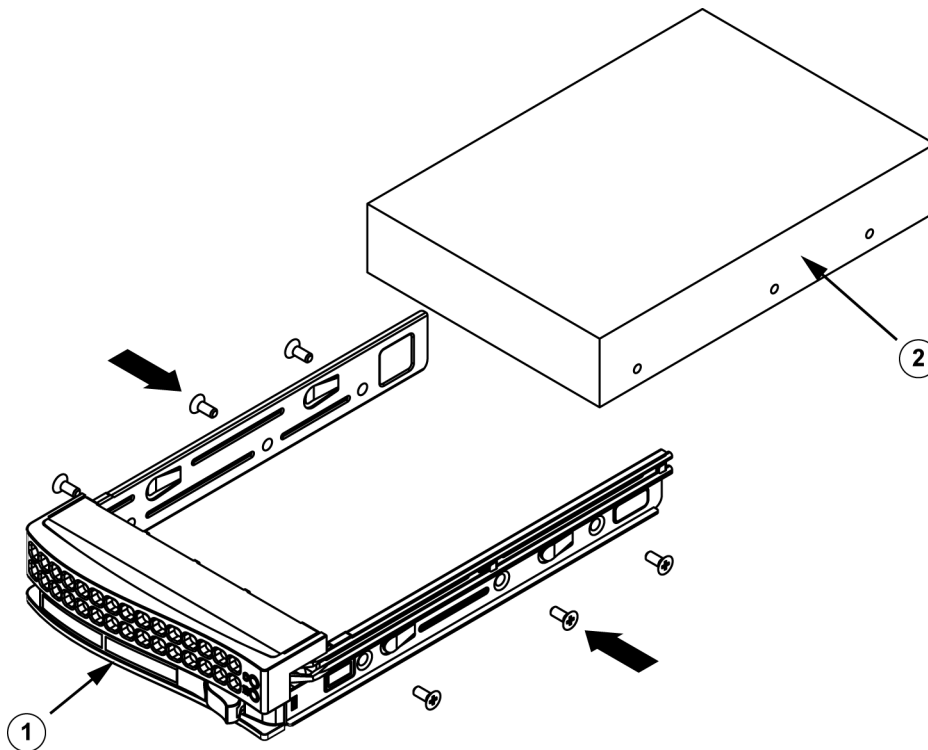

1	Drive carrier
2	SAS/SATA hard drive

5. Replace the drive carrier into the chassis bay. Make sure that the drive carrier handle is completely closed.

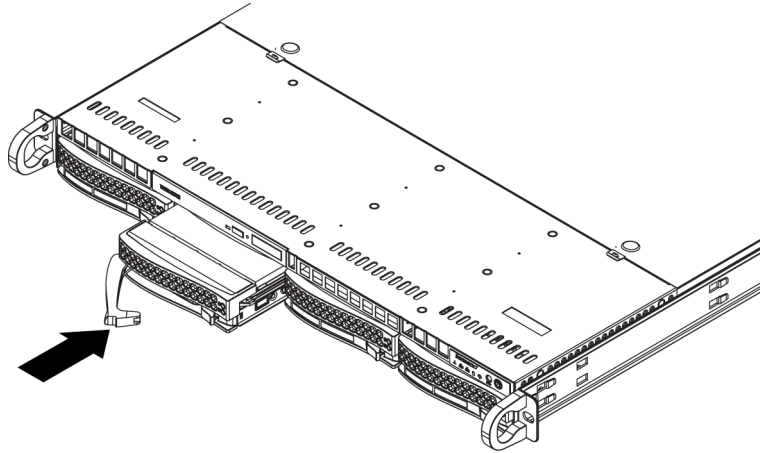
**Notice!**

We recommend using the respective Bosch hard disk drives. The hard disk drives as one of the critical component are carefully selected by Bosch based on available failure rates. HDD – not delivered from Bosch – are not supported. Information on supported HDDs can be found in the datasheet in the Bosch Online Product Catalog.

3.3**Installing a DVD-ROM or floppy drive**

The Bosch models come without a DVD-ROM. Due to the Bosch specific setup a DVD-ROM drive is not needed for operations and / or maintenance.

To install or replace a DVD-ROM or floppy drive:

1. Turn off the system and if necessary, remove the unit from the rack and the front bezel from the chassis.
2. Remove the chassis cover.
3. Unplug the drives power and data cables from the motherboard and/or backplane.
4. If you are adding a new drive:
Remove the mini-bezel (grate) from the drive bay. The bezel can be removed by pulling out the hard drive beneath the DVD-ROM or floppy drive bay, then pulling the mini-bezel forward.
If you are replacing a drive:
Locate the locking tab at the rear (left hand side when viewed from the front) of the DVD-ROM or floppy drive. Push the tab toward the drive and push the drive unit out the front of the chassis.
5. Insert the new drive unit in the slot until the tab locks in place.
6. Reconnect the data and power cables.
7. Replace the chassis cover. replace the unit in the rack, if necessary, then turn on the system.

3.4**Replacing the internal transcoder device**

The chassis model includes an internal USB transcoder device.

**Notice!**

To replace or install the transcoder device, please apply to one of the Bosch RMA helpdesks.

3.5 Installing the motherboard

Motherboard problems will be handled by trained support people only.

3.6 Installing the air shroud

Air shrouds concentrate airflow to maximize fan efficiency. The air shroud does not require screws to set up.

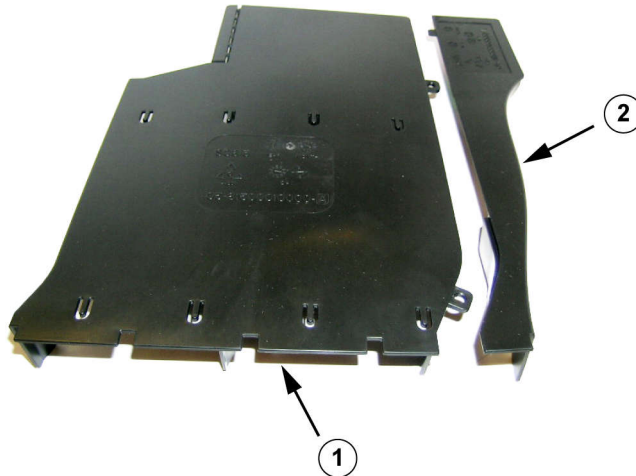

Air shroud with the Optional Flap Removed

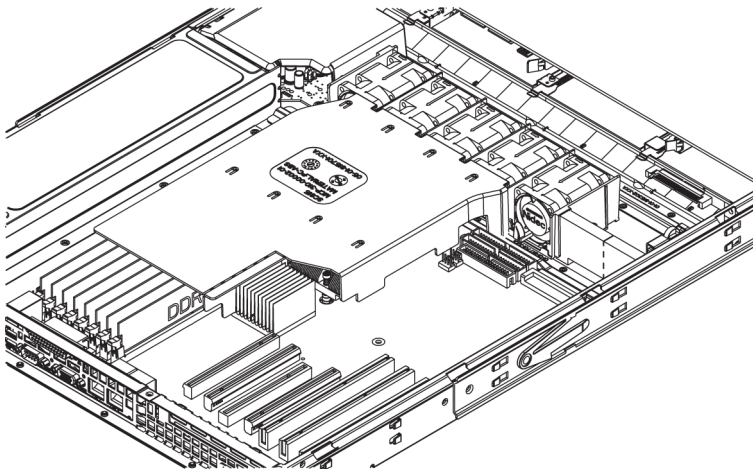

To install the air shroud:

1. Remove the chassis cover.
2. If your motherboard uses between 9 and 16 DIMMS, skip this step. If your motherboard uses 8 DIMMS, you must remove the optional flap. To do so:
 - With the fan side facing you, hold the air shroud with your left hand on the main shroud component and right hand on the optional flap.
 - Gently twist with your right hand by lifting the fan side and lowering the other end of the optional flap.
3. Place the air shroud in your chassis with the fan side touching the edge of the fans.
4. Replace the chassis cover.

To check the air flow:

1. Make sure there are no objects to obstruct airflow in and out of the chassis. In addition, if you are using a front bezel, make sure the bezel's filter is replaced periodically.

2. Do not operate the system without drives or drive trays in the drive bays. Use only recommended material.
3. Make sure no wires or foreign objects obstruct air flow through the chassis. Pull all excess cabling out of the airflow path or use shorter cables. The control panel LEDs inform you about system status.

3.7

System fans

The system fans provide cooling for the chassis. These fans circulate air through the chassis as a means of lowering the chassis internal temperature.



Warning!

The fans might still be turning when you remove the fan assembly from the chassis. Keep fingers, screwdrivers, and other objects away from the openings in the fan assembly's housing.

To add a system fan

1. Turn off the power to the system and unplug the system from the outlet.
2. Remove the dummy fan from the fan tray.
3. Place the new fan into the vacant space in the housing. Make sure the arrows on the top of the fan (indicating air direction) point in the same direction as the arrows on the other fans.
4. Connect the fan wires to the fan headers on the server board.
5. Power up the system and make sure that the fan is working properly before replacing the chassis cover.

The chassis includes four pre-installed fans. One or two extra slots are available so that additional fans may be added.

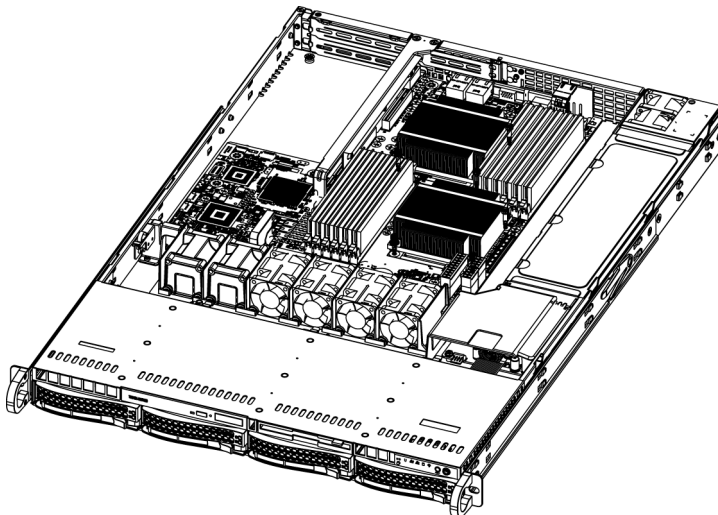

To replace a system fan

1. If necessary, open the chassis while the power is running to determine which fan has failed. Never run the system for an extended period of time with the chassis open.
2. Turn off the power to the system and unplug the power cord from the outlet.
3. Remove the failed fan's wiring from the motherboard.
4. Lift the failed fan from the chassis and pull it completely out from the motherboard.
5. Place the new fan into the vacant space in the housing while making sure the arrows on the top of the fan (indicating air direction) point in the same direction as the arrows on the other fans.
6. Reconnect the fan wires to the exact same chassis fan headers as the previous fan.
7. Reconnect the power cord, turn on the system and make sure that the fan is working properly before replacing the chassis cover.

3.8**Power supply**

The chassis has two redundant power supplies. The power supplies are auto-switching capable. This enables the power supplies to automatically sense and operate at a 100 V to 240 V input voltage.

**Warning!**

Redundant power supplies

This unit might have more than one power supply connection. To de-energize the unit, remove all connections.

3.8.1**Power supply failure**

If the power supply unit fails, the system will not shut down but you will need to replace the unit.

The power supply can be replaced without turning off the system if a redundant power supply is available. Replacement units can be ordered directly from Bosch RMA desk.

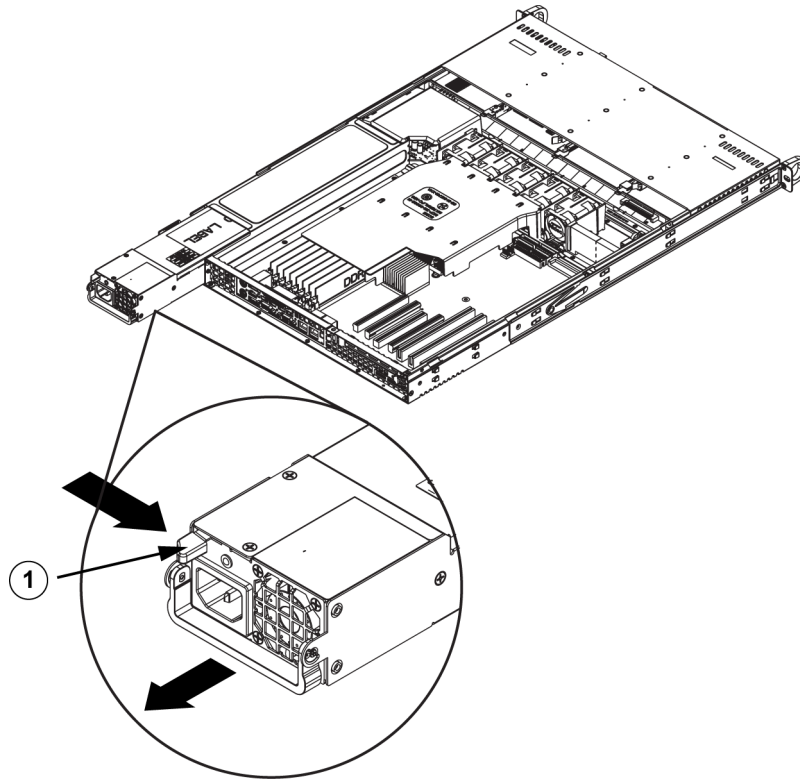

1	Release Tab
---	-------------

To replace the power supply:

1. Turn off the unit and unplug the power cord. If your chassis includes a redundant power supply (at least two power modules), you can leave the unit running and remove only one power supply.
2. Push the release tab on the back of the power supply.
3. Pull the power supply out using the handle provided.
4. Replace the failed power module with the same model.
5. Push the new power supply module into the power bay until you hear a click.
6. Plug the power cord back into the module and power up the server.

4 Rack installation

This chapter provides a quick setup checklist to get your chassis up and running. Following these steps in the order given should enable you to have the system operational within a minimum amount of time.

4.1 Unpacking the system

You should inspect the box the chassis was shipped in and note if it was damaged in any way. If the chassis itself shows damage, file a damage claim with the carrier who delivered it and notify the respective Bosch RMA desk.

You will also need it placed near at least one grounded power outlet.

Due to the weight of the system: After opening the top of the shipping box, one person should stand at either end and lift the disk array out together.

Be sure to read the safety precautions.

4.2 Preparing for setup

The box the system is shipped in includes a rack mount kit, which you will need to install the system into the rack.

Follow the steps in the order given to complete the installation process in a minimum amount of time. Read this section before you begin the installation procedure outlined in the sections that follow.

4.2.1 Choosing a setup location

- Situate the system in a clean, dust-free area that is well ventilated. Avoid areas where heat, electrical noise and electromagnetic fields are generated. Place the system near a grounded power outlet.
- Leave approximately 25 inches clearance in front of the rack to be able to open the front door completely.
- Leave approximately 30 inches of clearance in the back of the rack to allow for sufficient airflow and ease in servicing.
- Install the system only in a Restricted Access Location (dedicated equipment rooms, service closets and the like).



Notice!

This product is not suitable for use with visual display work place devices according to §2 of the the German Ordinance for Work with Visual Display Units.

4.2.2 Rack precautions



Warning!

To prevent bodily injury when mounting or servicing this unit in a rack, you must take special precautions to ensure that the system remains stable. The following guidelines are provided to ensure your safety:

- Ensure that the leveling jacks on the bottom of the rack are fully extended to the floor with the full weight of the rack resting on them.
- In single rack installations, attach stabilizers to the rack.
- If the rack is provided with stabilizing devices, install the stabilizers before mounting or servicing the unit in the rack.

- This unit should be mounted at the bottom of the rack if it is the only unit in the rack.
- When mounting this unit in a partially filled rack, load the rack from the bottom to the top with the heaviest component at the bottom of the rack.
- In multiple rack installations, couple the racks together.
- Always make sure the rack is stable before extending a component from the rack.
- Extend only one component at a time - extending two or more simultaneously may cause the rack to become unstable.

4.2.3

General system precautions

- Review the electrical and general safety precautions that came with the components you are adding to your chassis.
- Determine the placement of each component in the rack before installing the rails.
- Install the heaviest components on the bottom of the rack first, and then work up.
- Use a regulating uninterruptible power supply (UPS) to protect the system from power surges, voltage spikes if you want to keep your system operating in case of a power failure.
- Allow the SATA hard drives and power supply modules to cool before touching them.
- Always keep the rack's front door and all panels and components on the system closed when not servicing to maintain proper cooling.

4.2.4

Rack mounting considerations

Ambient operating temperature

If installed in a closed or multi-unit rack assembly, the ambient operating temperature of the rack environment may be greater than the ambient temperature of the room. Therefore, consideration should be given to installing the equipment in an environment compatible with the manufacturer's maximum rated ambient temperature (T_{mra}).

Reduced airflow

Equipment should be mounted into a rack so that the amount of airflow required for safe operation is not compromised.

Mechanical loading

Equipment should be mounted into a rack so that a hazardous condition does not arise due to uneven mechanical loading.

Circuit overloading

Consideration should be given to the connection of the equipment to the power supply circuitry and the effect that any possible overloading of circuits might have on overcurrent protection and power supply wiring. Appropriate consideration of equipment nameplate ratings should be used when addressing this concern.

Reliable ground

A reliable ground must be maintained at all times. To ensure this, the rack itself should be grounded. Particular attention should be given to power supply connections other than the direct connections to the branch circuit (i.e. the use of power strips, etc.).

4.3

Rack mounting instructions

This section provides information on installing the chassis into a rack unit. There are a variety of rack units on the market, which may mean the assembly procedure will differ slightly. You should also refer to the installation instructions that came with the rack unit you are using.



Notice!

This rail will fit a rack between 26" and 33.5" deep.

4.3.1 Identifying the sections of the rack rails

The chassis package includes two rail assemblies in the rack mounting kit. Each assembly consists of two sections:

- an inner fixed chassis rail that secures directly to the chassis
- an outer fixed rack rail that secures directly to the rack itself.

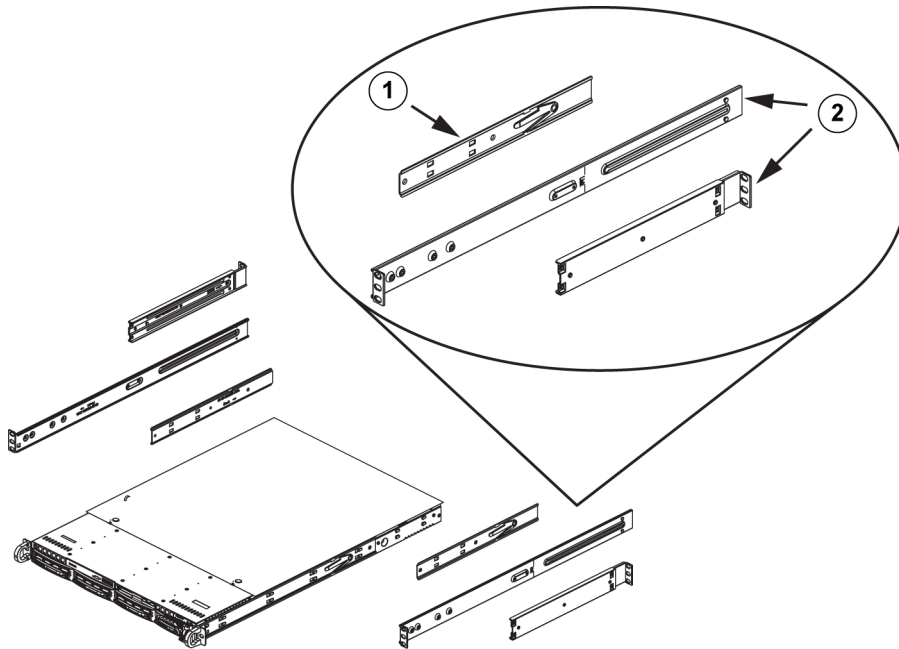

1	Rail extension (inner rail is pre-installed on the chassis)
2	Outer rails

4.3.2 Installing the inner rails

The chassis includes a set of inner rails which are in two sections: inner rails and inner rail extensions. The inner rails are pre-attached and do not interfere with normal use of the chassis if you decide not to use a server rack. Attach the inner rail extension to stabilize the chassis within the rack.

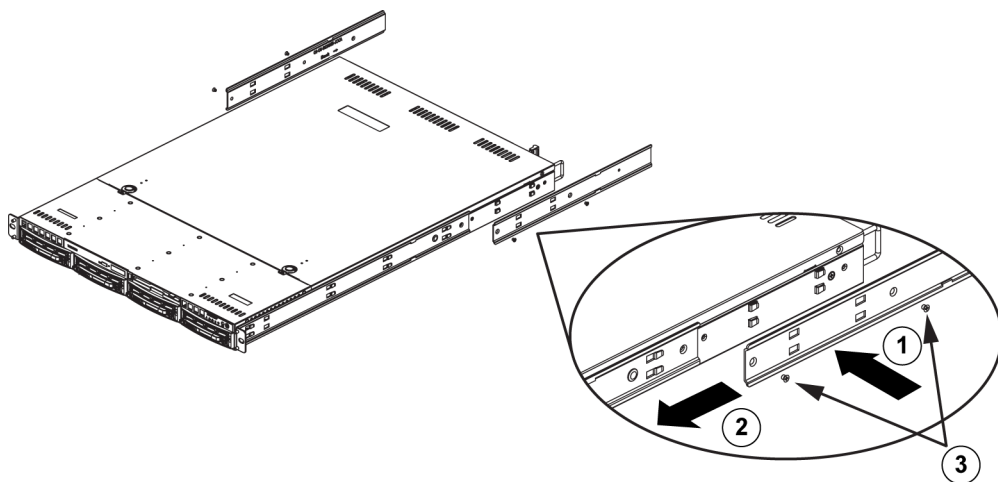

To install the inner rails:

1. Place the inner rail extensions on the side of the chassis aligning the hooks of the chassis with the rail extension holes. Make sure the extension faces "outward" just like the pre-attached inner rail.
2. Slide the extension toward the front of the chassis.
3. Secure the chassis with 2 screws as illustrated.
4. Repeat steps for the other inner rail extension.

4.3.3 Assembling the outer rails

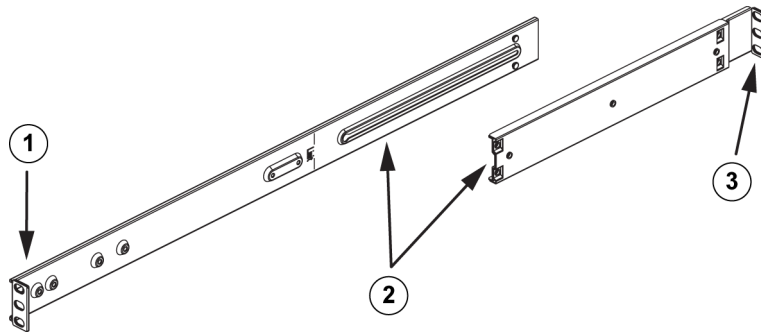

To assemble the outer rails:

1. Secure to the front of the rack.
2. Attach the two sections of the outer rail together.
3. Secure to the rear of the rack.

4.3.4 Installing the outer rails to the rack

Outer rails attach to the rack and hold the chassis in place. The outer rails extend between 30 inches and 33 inches.

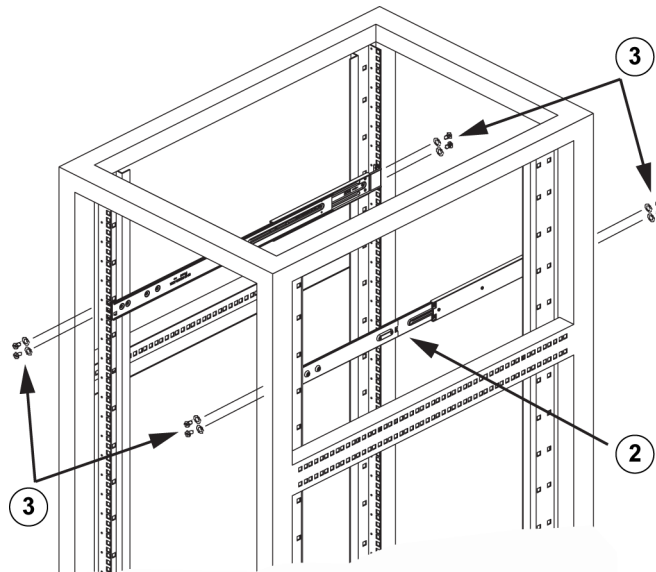

To install the outer rails to the rack

1. Attach the longer section of the outer rail to the outside of the shorter section of the outer rail. You must align the pins with the slides. Both ends of the outer rail must face the same direction in order to be secured to the rack.
2. Adjust both sections of the outer rail to the proper length so that the rail fits snugly within the rack.

3. Secure the longer section of the outer rail to the front of the rack with two M5 screws and the shorter section to the rear side of the rack with two M5 screws.
4. Repeat steps for the remaining outer rail.

See also:

Assembling the outer rails, page 25

4.3.5 Installing the chassis into the rack

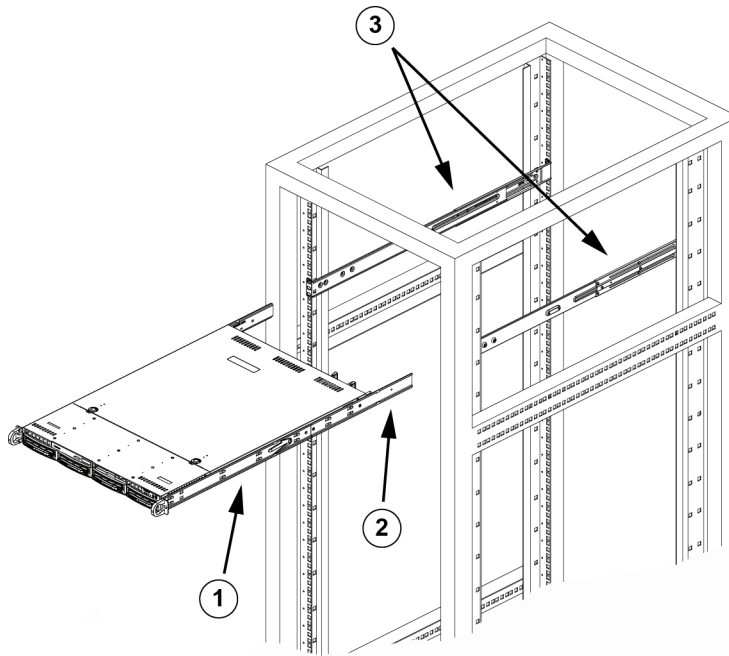

1	Inner rail	3	Outer rails
2	Rail extension		

To install the chassis into a rack

1. Confirm that chassis includes the inner rails and rail extensions. Also, confirm that the outer rails are installed on the rack.
2. Line chassis rails with the front of the rack rails.
3. Slide the chassis rails into the rack rails, keeping the pressure even on both sides (you may have to depress the locking tabs when inserting). When the system has been pushed completely into the rack, you should hear the locking tabs click.
4. (Optional) Insert and tightening the thumbscrews that hold the front of the system to the rack.

**Warning!**

Do not pick up the unit with the front handles. The handles are designed to pull the system from a rack only.

**Warning!**

Stability hazard

Before sliding the unit out for servicing make sure that the rack stabilizing mechanism is in place, or the rack is bolted to the floor. Failure to stabilize the rack can cause the rack to tip over.

See also:

Rack precautions, page 22

4.3.6**Installing the chassis into a Telco rack**

To install the chassis into a Telco type rack, use two L-shaped brackets on either side of the chassis (four in total). First, determine how far the chassis will extend out the front of the rack. Larger chassis should be positioned to balance the weight between front and back. If a bezel is included on the chassis, remove it. Then attach the two front brackets to each side of the chassis, then the two rear brackets positioned with just enough space to accommodate the width of the Telco rack. Finish by sliding the chassis into the rack and tightening the brackets to the rack.

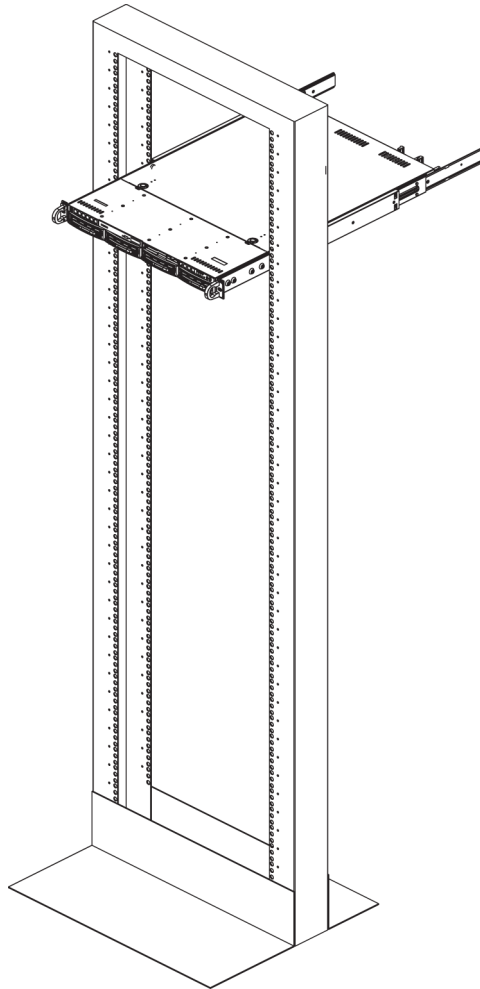
**4.4****Turning on the system**

The last thing to be done is to provide input power to the system.

To turn on the system:

1. Plug the power cord from the power supply unit into a high-quality power strip that offers protection from electrical noise and power surges. We recommended using an uninterruptible power supply (UPS).
2. Press the power button on the control panel to turn on the system.

5 Appendix

This chapter gives information for supporting and troubleshooting.

5.1 Motherboard

All graphics shown in this chapter were based upon the latest PCB Revision available at the time of publishing of the manual. The motherboard you've received can differ from the graphics shown in this chapter.

5.1.1 Motherboard layout

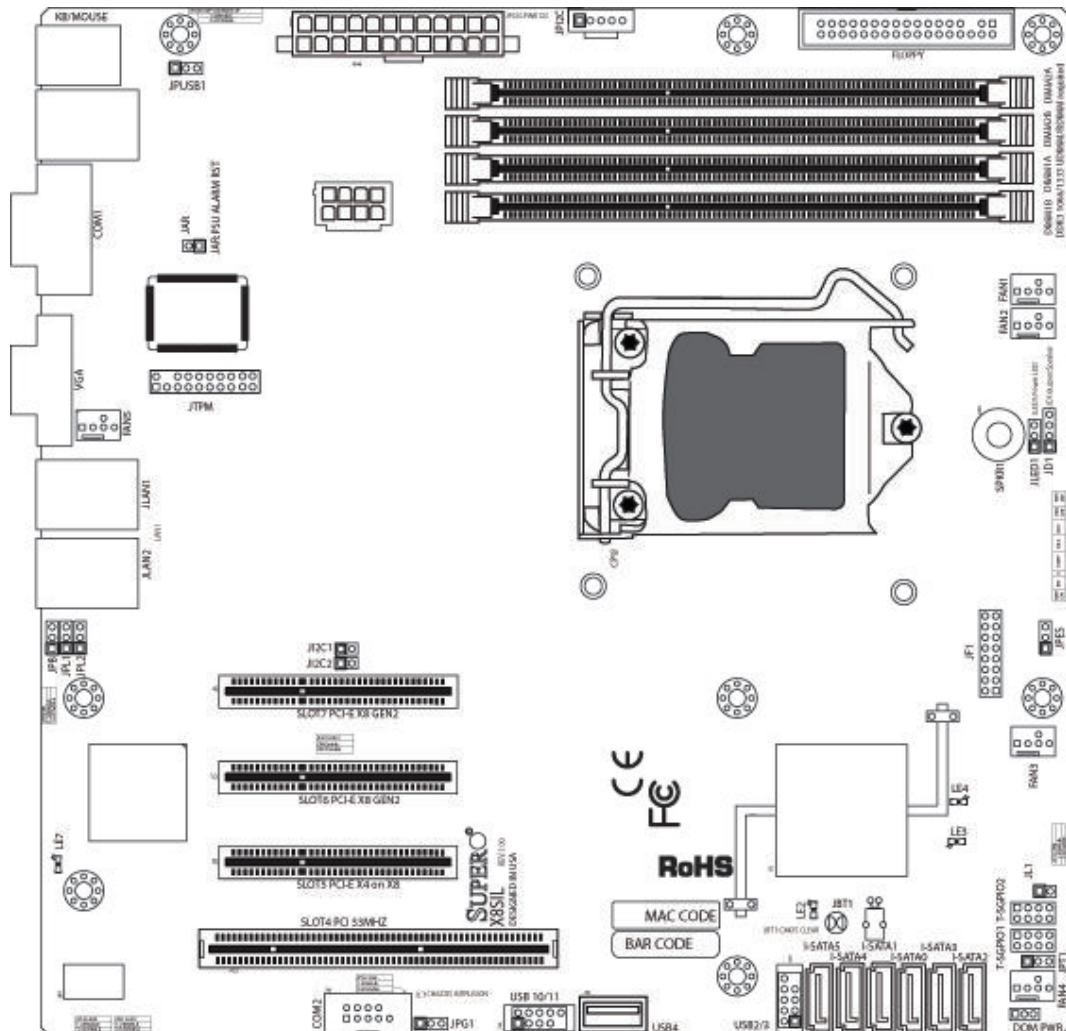

Figure 5.1: Motherboard layout

Important notes to the user:

- Jumpers not indicated are for testing only.
- When LE2 (Onboard Power LED Indicator) is on, system power is on. Unplug the power cable before installing or removing any components.
- All systems have a SATA DOM connected to Serial ATA ports (I-SATA-5) with a small power connector (DOM PWR).
- SATA-DOM: Is plugged in connector I-SATA-5 on the motherboard.

5.1.2 Motherboard component overview

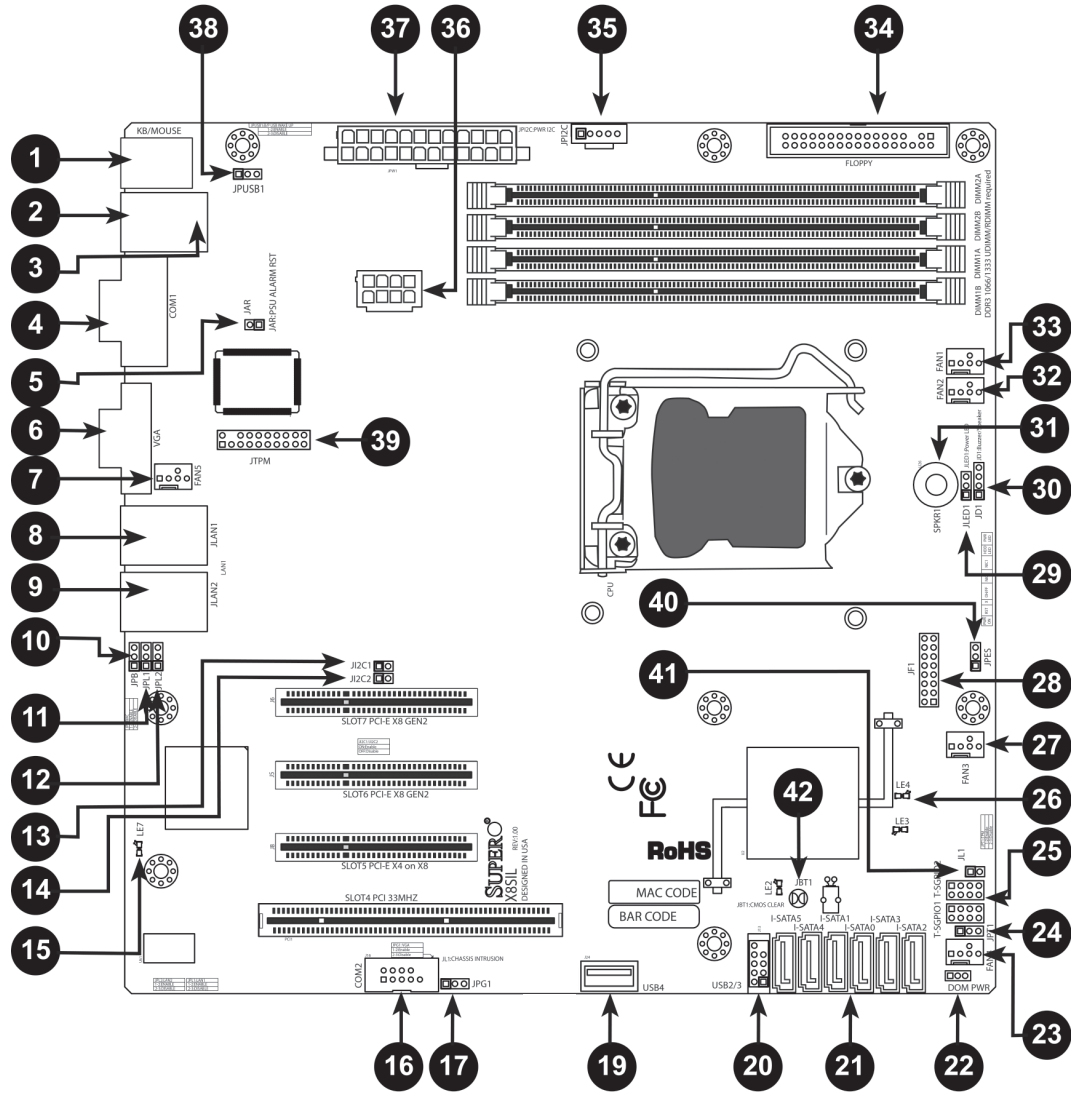

Figure 5.2: Motherboard – component overview

X8SIL/X8SIL-F/X8SIL-V jumpers

Number	Jumper	Description	Default
38	JPUSB1	BP USB0/1 Wake-up	Pins 1-2 (Enabled)
42	JBT1	CMOS Clear	
40	JPES	Energy Saving Feature	Pins 2-3 (Disabled)
13,14	J12C1/J12C2	SMB to PCI Slots	
17	JPG1	Onboard VGA Enable	Pins 1-2 (Enabled)
11,12	JPL1/JPL2	LAN1/LAN2 Enable	Pins 1-2 (Enabled)
24	JPT1	TPM Enable	Pins 1-2 (Enabled)
10	JPB	BMC Jumper	Pins 1-2 (Enabled)

X8SIL/X8SIL-F/X8SIL-V headers/connectors

Number	Connector	Description
4,16	COM1/COM2	COM1/2 Serial connection headers
33,32,27,23,7	Fans 1~5	System/CPU fan headers
34	Floppy	Floppy Disk Drive connector
5	JAR	Alarm Reset
30	JD1	Speaker header (Pins 3/4: Internal, 1~4:External)
28	JF1	Front Panel Control header
41	JL1	Chassis Intrusion header
29	JLED	Power LED Indicator header
37	JPW1	24-pin ATX main power connector (required)
36	JPW2	+12V 8-pin CPU power connector (required)
1	KB/Mouse	Keyboard/mouse connectors
8,9	LAN1~LAN2,	Gigabit Ethernet (RJ45) ports (LAN1/LAN2)
21	I-SATA 0~5	Serial ATA ports (X8SIL has 4 Serial ATA Ports)
2	IPMI	IPMI LAN Port (X8SIL-F Only)
35	JPI2C	PWR supply (I2C) System Management Bus
31	SPKR1	Internal speaker/buzzer
25	T-SGPIO-0/1	Serial General Purpose IO headers (for SATA)
3,20	USB0/1	Backplane USB 0/1
19	USB 4	Type A USB Connector
18	USB 10/11	Front Panel USB header (X8SIL-F Only)
22	DOM PWR	Disk-On-Module (DOM) Power Connector
39	JTPM	Trusted Platform Module (TPM) Header
6	VGA	Onboard Video Port

X8SIL/X8SIL-F/X8SIL-V LED indicators

Number	LED	Description	Color/State	Status
26	LE4	Onboard Standby PWR LED Indicator	Green: Solid on	PWR On
15	LE7	IPMI Heartbeat LED (X8SIL-F Only)	Yellow: Blinking	IPMI: Normal

5.1.3 Motherboard features

CPU	Single Intel Xeon 3400 series processor in an LGA1156 socket.	
Memory	Four (4) 240-pin, DDR3 SDRAM DIMM sockets with support for up to 16GB of UDIMM or up to 32GB of RDIMM memory (ECC/DDR3 1333/1066/800 MHz memory only.)	
	Supports dual-channel memory bus	
	DIMM sizes	
	UDIMM	1 GB, 2 GB, and 4GB
	RDIMM	1 GB, 2GB, 4GB, and 8GB
Chipset	Intel 3420 Chipset (X8SIL-F/X8SIL-V)	
	Intel 3400 Chipset (X8SIL)	
Expansion Slots	Two (2) PCI Express 2.0 (x8) slot	
	One (1) PCI Express x4 (x8) slot	
	One (1) 32-bit PCI 33MHz slot	
Integrated Graphics	Matrox G200eW	
Network Connections	Two Intel 82574L Gigabit (10/100/1000 Mb/s) Ethernet Controllers for LAN 1 and LAN 2 ports.	
	Two (2) RJ-45 Rear IO Panel Connectors with Link and Activity LEDs	
	Single Realtek RTL8201N PHY to support IPMI 2.0 (X8SIL-F Only)	
I/O Devices	SATA Connections (X8SIL-F/X8SIL-V Only)	
	SATA Ports	Six (6)
	RAID (Windows)	RAID 0, 1, 5, 10
	RAID (Linux)	RAID 0, 1, 10
	SATA Connections (X8SIL Only)	
	SATA Ports	Four (4)
	Integrated IPMI 2.0 (X8SIL-F Only)	
	IPMI 2.0 supported by the WPCM450 Server BMC	
	Floppy Disk Drive	
	One (1) floppy drive interface (up to 1.44 MB)	
	USB Devices (X8SIL Only)	
	Two (2) USB ports on the rear IO panel	
	One (1) Type A internal connector	
	I/O Devices (Continued)	USB Devices (X8SIL-F/X8SIL-V Only)

	Two (2) USB ports on the rear IO panel
	Four (4) USB header connectors for front access
	One (1) Type A internal connector
	Keyboard/Mouse
	PS/2 Keyboard/Mouse ports on the I/O backplane
	Serial (COM) Ports
	Two (2) Fast UART 16550 Connections: one 9-pin RS-232 port and one header
	Super I/O
	Winbond Super I/O 83627DHG-P
BIOS	32 Mb SPI AMI BIOS SM Flash BIOS
	DMI 2.3, PCI 2.3, ACPI 1.0/2.0/3.0, USB Keyboard and SMBIOS 2.5
Power Configuration	ACPI/ACPM Power Management
	Main switch override mechanism
	Keyboard Wake-up from Soft-Off
	Internal/External moder ring-on
	Power-on mode for AC power recovery
PC Health Monitoring	CPU Monitoring
	Onboard voltage monitors for CPU core, +3.3V, +5V, +/-12V, +3.3V Stdbby, +5V Stdbby, VBAT, HT, Memory, Chipset
	CPU 3-Phase switching voltage regulator
	CPU/System overheat LED and control
	CPU Thermal Trip support
	Thermal Monitor 2 (TM2) support
	Fan Control
	Fan status monitoring with firmware 4-pin (Pulse Width Modulation) fan speed control
	Low noise fan speed control
System Management	PECI (Platform Environment Configuration Interface) 2.0 support
	System resource alert via Supero Doctor III
	SuperoDoctor III, Watch Dog, NMI
	Chassis Intrusion Header and Detection
CD Utilities	BIOS flash upgrade utility

	Drivers and software for Intel 3400/3420 chipset utilities
Other	ROHS 6/6 (Full Compliance, Lead Free)
Dimensions	Micro ATX form factor, 9.6" x 9.6"

5.1.4

Block diagram

The following graphic shows the block diagram of the motherboard.

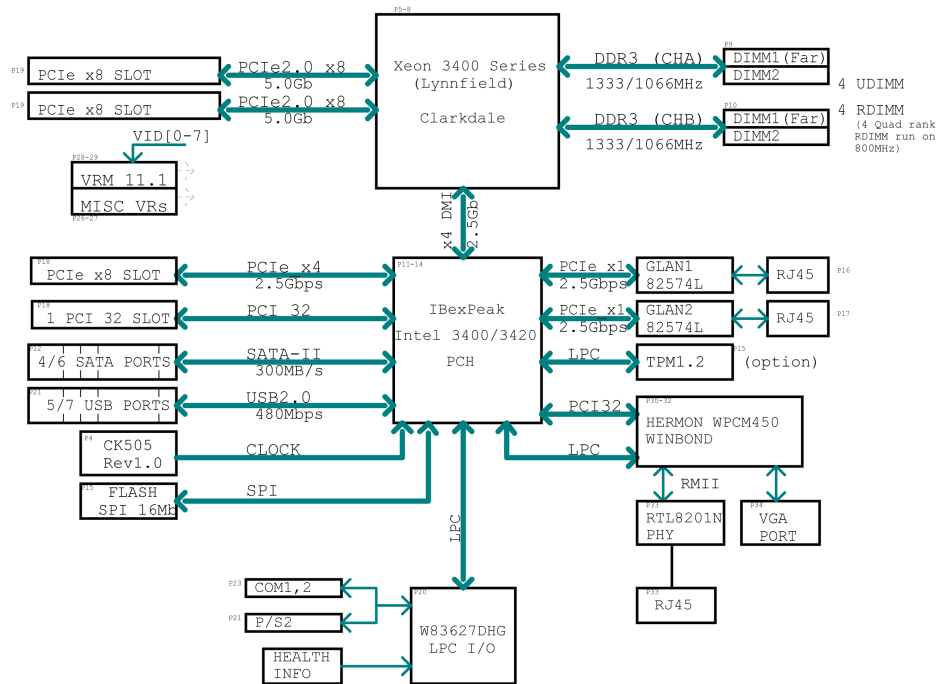

Figure 5.3: Block diagram



Notice!

This is a general block diagram and may not exactly represent the features on your motherboard. See the Motherboard Features pages for the actual specifications of each motherboard.

5.2

Chipset overview

The X8SIL/X8SIL-F/X8SIL-V supports the Intel Xeon 3400 processor series. Built upon the functionality and the capability of the single-chip Intel 3400 chipset, the X8SIL/X8SIL-F/X8SIL-V motherboard provides the performance and feature set required for single-processor-based systems with configuration options optimized for entry-level server platforms. The high-speed Direct Media Interface (DMI) featured in the Intel 3400/3420 chipset enables the X8SIL/X8SIL-F/X8SIL-V motherboard to offer a high-speed Direct Media Interface (DMI) for chip-to-chip true isochronous communication with the processor. This feature allows the X8SIL/X8SIL-F/X8SIL-V to achieve up to 10 Gb/s of software-transparent data transfer on each direction, achieving better performance than comparable systems. The X8SIL/X8SIL-F/X8SIL-V also features a TCO timer (to enable the system to recover from a software/hardware lock), ECC Error Reporting, Function Disable and Intruder Detect.

Intel 3400/3420 chipset features

- Direct Media Interface (up to 10 Gb/s transfer, Full Duplex)
- Intel Matrix Storage Technology and Intel Rapid Storage Technology
- Dual NAND Interface
- Intel I/O Virtualization (VT-d) Support
- Intel Trusted Execution Technology Support
- PCI Express 2.0 Interface (up to 5.0 GT/s)
- SATA Controller (up to 3G/s)
- Advanced Host Controller Interface (AHCI)

5.3 PC health monitoring

This section describes the PC health monitoring features of the X8SIL/X8SIL-F/X8SIL-V. These features are supported by an onboard System Hardware Monitor chip.

Recovery from AC power loss

BIOS provides a setting for you to determine how the system will respond when AC power is lost and then restored to the system. You can choose for the system to remain powered off (in which case you must hit the power switch to turn it back on) or for it to automatically return to a power on state. The default setting is Last State.

Onboard voltage monitoring

The onboard voltage monitor will scan the following voltages continuously: CPU core, +3.3V, +5V, +/-12V, +3.3V Stdbby, +5V Stdbby, VBAT, HT, Memory, Chipset. Once a voltage becomes unstable, it will give a warning or send an error message to the screen. Users can adjust the voltage thresholds to define the sensitivity of the voltage monitor by using SD III.

Fan status monitor with software

PC health monitoring can check the RPM status of the cooling fans via Supero Doctor III.

CPU overheat LED and control

This feature is available when the user enables the CPU overheat warning feature in the BIOS. This allows the user to define an overheat temperature. When this temperature reaches this pre-defined overheat threshold, the CPU thermal trip feature will be activated and it will send a signal to the buzzer and, at the same time, the CPU speed will be decreased.

5.4 Power configuration settings

This section describes the features of your motherboard that deal with power and power settings.

Slow blinking LED for suspend-state indicator

When the CPU goes into a suspend state, the chassis power LED will start blinking to indicate that the CPU is in the suspend mode. When the user presses any key, the CPU will wake-up and the LED indicator will automatically stop blinking and remain on.

BIOS support for USB keyboard

If the USB keyboard is the only keyboard in the system, it will function like a normal keyboard during system boot-up.

Main switch override mechanism

When an ATX power supply is used, the power button can function as a system suspend button. When the user presses the power button, the system will enter a SoftOff state. The monitor will be suspended and the hard drive will spin down. Pressing the power button again to wake-up the whole system. During the SoftOff state, the ATX power supply provides power the system to keep the required circuitry "alive". In case the system malfunctions and you want to turn off the power, just press and hold the power button for 4 seconds. The power will turn off and no power will be provided to the motherboard.

5.5 Power supply

A stable power source is necessary for proper and reliable operation. It is even more important for processors that have high CPU clock rates of 1 GHz and faster.

The X8SIL/X8SIL-F/X8SIL-V accommodates ATX12V standard power supplies. Although most power supplies generally meet the specifications required by the CPU, some are inadequate. A 2-Amp of current supply on a 5V Standby rail is strongly recommended.

It is strongly recommended that you use a high quality power supply that meets ATX12V standard power supply Specification 1.1 or later. It is also required that the 12V 8-pin power connection (JPW2) be used for adequate power supply. In areas where noisy power transmission is present, you may choose to install a line filter to shield the computer from noise. It is recommended that you also install a power surge protector to help avoid problems caused by power surges.

DIVAR IP 6000 does not have a function to determine pre-failure of a power supply. The power supply will have the LED to show it is "OK" or "failed" by showing the color green or amber for the respective status. When the power supply fails, it shows amber, when it is functioning correctly it shows green.

5.6 Super I/O

The disk drive adapter functions of the Super I/O chip include a floppy disk drive controller that is compatible with industry standard 82077/765, a data separator, write pre-compensation circuitry, decode logic, data rate selection, a clock generator, drive interface control logic and interrupt and DMA logic. The wide range of functions integrated onto the Super I/O greatly reduces the number of components required for interfacing with floppy disk drives. The Super I/O supports two 360 K, 720 K, 1.2 M, 1.44 M or 2.88 M disk drives and data transfer rates of 250 Kb/s, 500 Kb/s or 1 Mb/s.

It also provides two high-speed, 16550-compatible serial communication ports (UARTs). Each UART includes a 16-byte send/receive FIFO, a programmable baud rate generator, complete modem control capability and a processor interrupt system. Both UARTs provide legacy speed with baud rate of up to 115.2 Kbps as well as an advanced speed with baud rates of 250 K, 500 K, or 1 Mb/s, which support higher speed modems.

The Super I/O provides functions that comply with ACPI (Advanced Configuration and Power Interface), which includes support of legacy and ACPI power management through a SMI or SCI function pin. It also features auto power management to reduce power consumption.

5.7 iSCSI support

The X8SIL/X8SIL-F/X8SIL-V motherboard supports the iSCSI Internet Protocol. iSCSI is an IP networking standard used to link and manage data storage, and transfer data across the internet and private intranets through long distance. iSCSI can be used to transmit data over local area networks (LANs), wide area networks (WANs), or the Internet. It can enable location-independent data storage and retrieval.

iSCSI allow clients to issue SCSI commands to remote SCSI storage devices and allow data centers to consolidate remote storage devices into storage arrays, giving an illusion of locally-attached disks to host servers. Unlike fiber-optic networks that require special cabling, iSCSI can run over long distance using existing networks.

For the X8SIL/X8SIL-F/X8SIL-V motherboard, iSCSI is supported on LAN 1. This can be enabled through the BIOS: Advanced => PCI/PnP Configuration => Onboard LAN1 Option ROM Select.

5.8 Overview of the Nuvoton BMC controller

The Nuvoton WPCM150 is a combined Baseboard Management Controller and 2D/VGA-compatible Graphics Core with PCI interface, Virtual Media and Keyboard, and a Keyboard/Video/Mouse Redirection (KVMR) module.

The WPCM150 interfaces with the host system via a PCI interface to communicate with the Graphics core. It supports USB 2.0 and 1.1 for remote keyboard/mouse/virtual media emulation. It also provides an LPC interface to control Super I/O functions and connects to the network via an external Ethernet PHY module or shared NCSI connections.

The Nuvoton BMC communicates with onboard components via six SMBus interfaces, fan control, Platform Environment Control Interface (PECI) buses, and General Purpose I/O (T-SGPIO) ports.

It also includes the following features:

- One X-Bus parallel interface for expansion I/O connections
- Three ADC inputs, Analog and Digital Video outputs
- Two serial for boundary scan and debug

There are two different versions of the Nuvoton BMC chip that are used in this product series. The Nuvoton WPCM150 (Manufacturer P/N WPCM150GA0BX5) which includes all of the features above, is the chip installed in the X8SIL motherboard. Another version, the Nuvoton WPCM450 (Manufacturer P/N WPCM450RA0BX) also has all the features as described above plus IPMI 2.0 support. This particular chip is installed in the X8SIL-F and X8SIL-V models. However, IPMI is supported only on the X8SIL-F motherboard.

5.9 RAID disaster recovery

A failure of multiple disks (offline - status) happens in different ways that involve various, sometimes unusual methods to restore the RAID system. Normally, the cache of the RAID disks should be set to "write through" if no UPS is active, and the controller be buffered by a battery, when controller cache is set to "write back". Nevertheless, both caches have a great influence on the RAID performance.

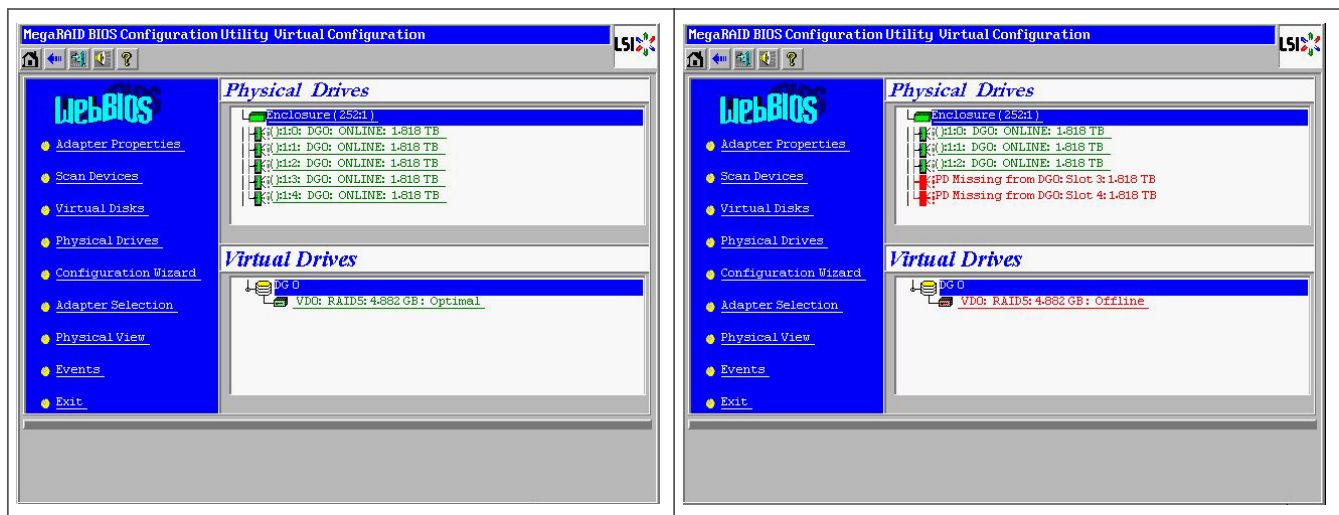

Basically, the RAID controller writes the raidconfiguration - information (COD = configuration-on-disk) in an only field on each disk managed by the controller. The data area of a disk is never used by this, no matter, how often you write and delete the RAID configuration. "New" or "Clear" Configuration deletes the COD, if available.

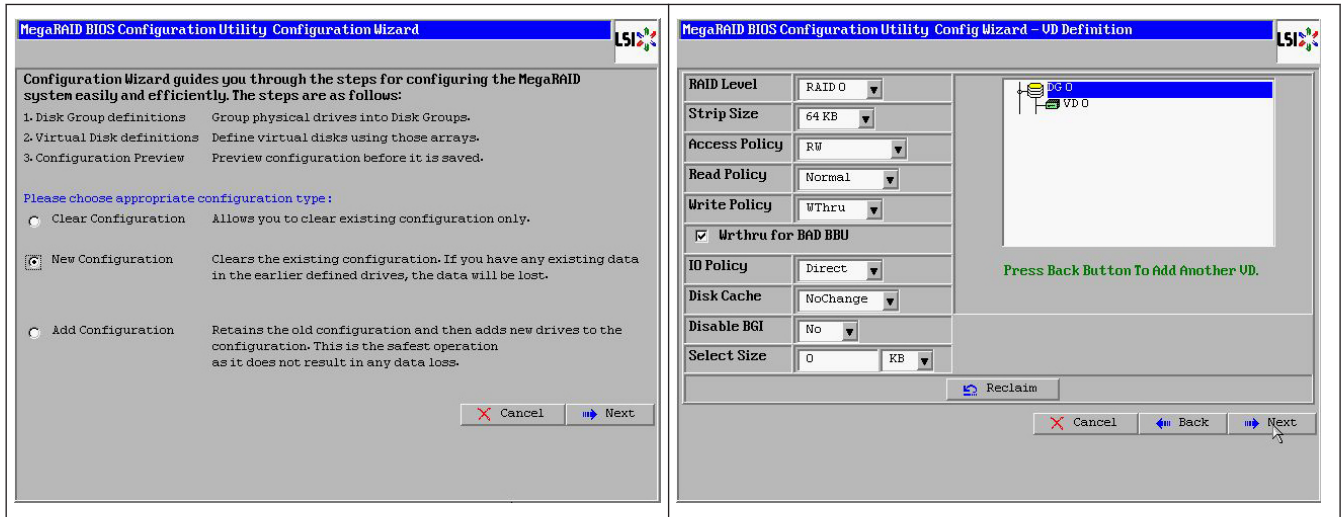

"Save Configuration" saves the new COD. "Initialize" deletes the Disk Data (OS).

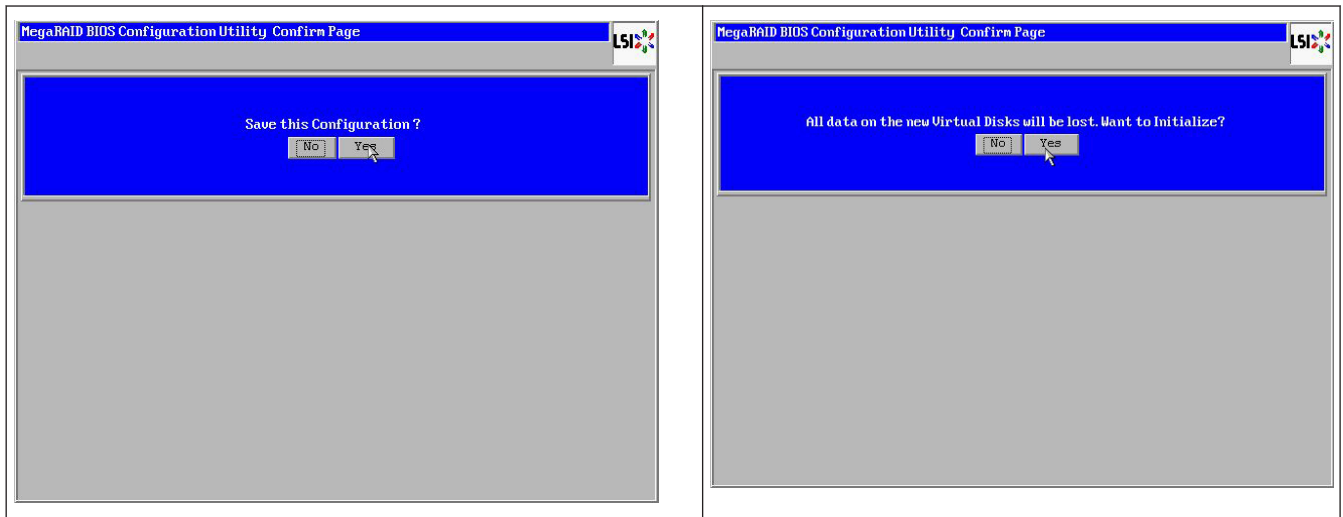

The data area can only be deleted with a "fast" or "full" initialization; as long as an initialization is omitted, the OS file system is still there. But OS only boots, if the original RAID configuration is restored (if no multiple hardware damage exists).
 If, for example, the RAID is deleted accidentally (eg. with "clear" or "new configuration" instead of add), and the configuration is set up exactly (in disk order and stripesize) the same as before, the data area on the remaining operating system boots again without any problem. This fact is useful when the RAID (COD) was lost for some reason, but the disks are OK.

5.9.1 Multiple disks failed - theory

If multiple disks have failed (by power failure, backplane error, etc.), it is important to know the order, which disk failure degraded the RAID (first fail) and which disk ID prevented a further access to the RAID (second fail).

For instance:

- RAID 5 (4 disks) got from rebuild to offline, no Hot Spare
- 2 disks online
- 2 disks missing
- 2 disks "foreign configuration" or "unconfigured good"

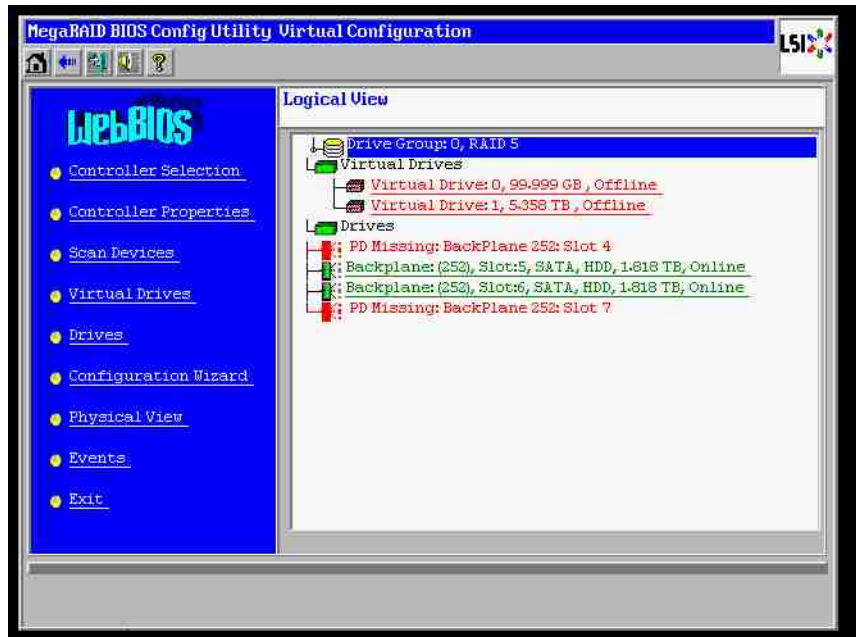

The rebuild only could start, when the other three disks were online before: the rebuild disk is "first fail", degraded RAID was rebuilding. "Foreign" disk is the "second fail" disk, one of the disks, from which the parity data was copied to the rebuilding disk before the crash.

If in "degraded" mode, the surviving disks was still used, a "parity – inconsistency" between the first failed (first fail) and the second failed disk occurs. But a RAID 5 is not usable when a second disk fails, so no inconsistency can exist.

If you try to restore the RAID, the first fail disk could be used for rebuild later (or a new disk). But the "second failed" disk must be used for hopefully get the offline RAID degraded again.

Two tools are useful to analyze what happened:

- the Event Viewer in the Controller Bios Utility
- the MegaCLI, a Command-Line Utility

How to use the Event Viewer in the Controller Bios Utility

Click on an event in the main screen; choose "physical" or "virtual drive" and an event class (informational, warning, critical or fatal); start at an appropriate sequence number (minus a few hundred), choose the number of events.

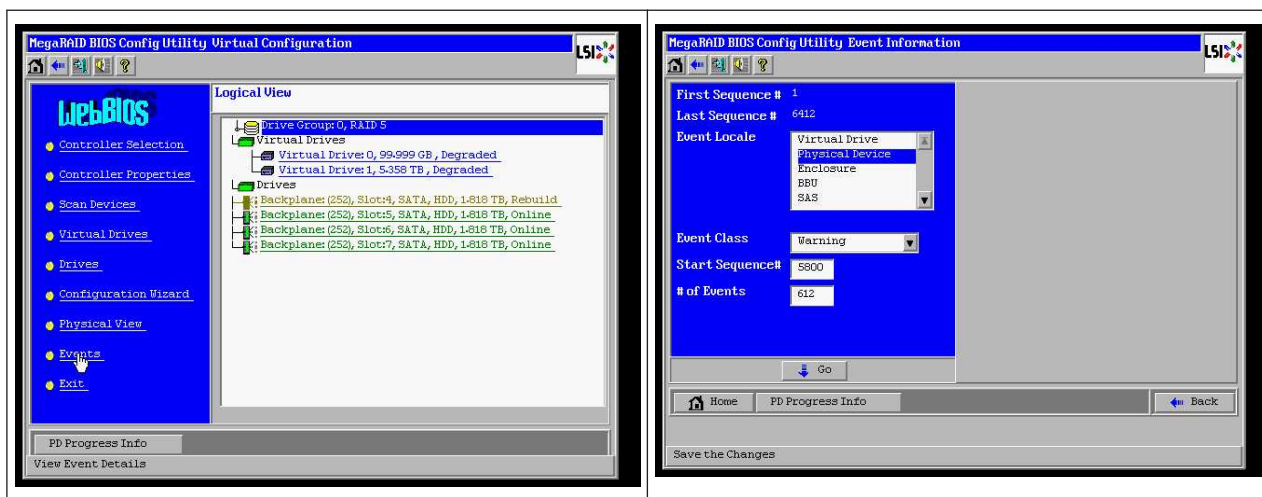

In this example, we choose a start sequence 5800 (from 6412) and all 612 events left. We find a timestamp, that PD (Physical Drive) 6 was removed. PD 4 stops rebuilding.

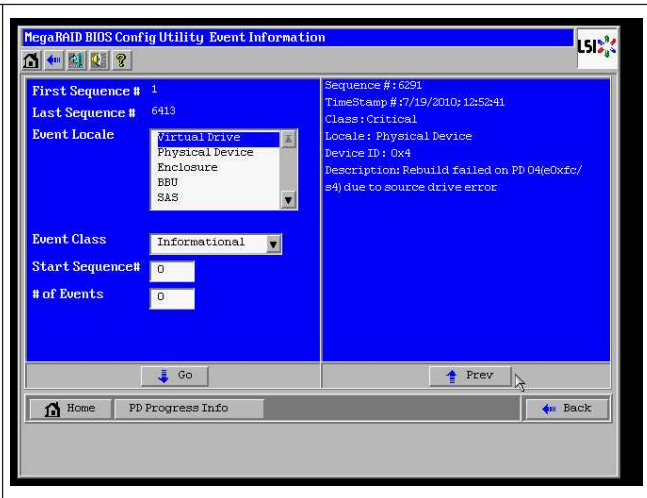
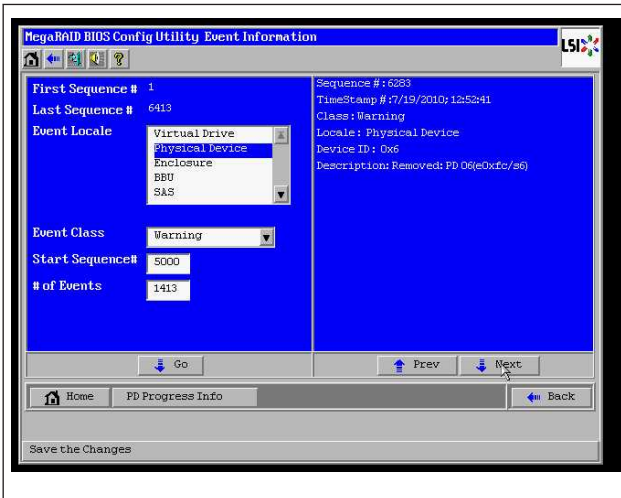

Finally, PD 4 is also removed.

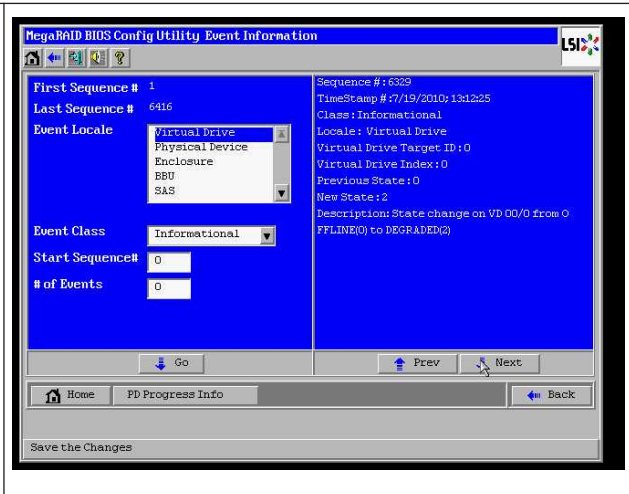
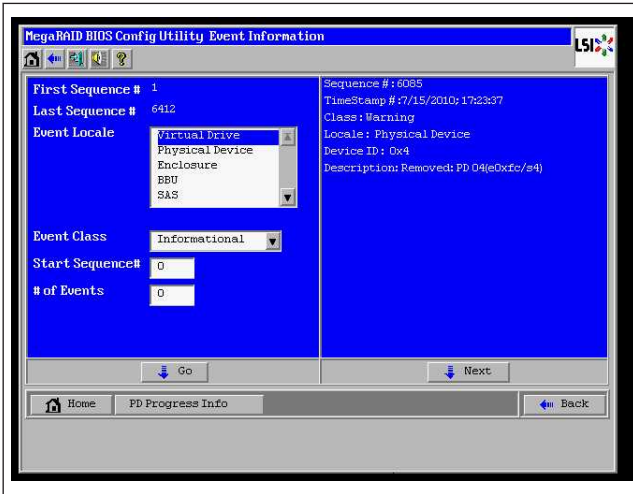

The VD event reports first a degraded state, then an offline state. The "first failed" disk was the rebuilding PD4. When PD6 failed, the rebuild stopped, when PD4 was gone, RAID gets offline.

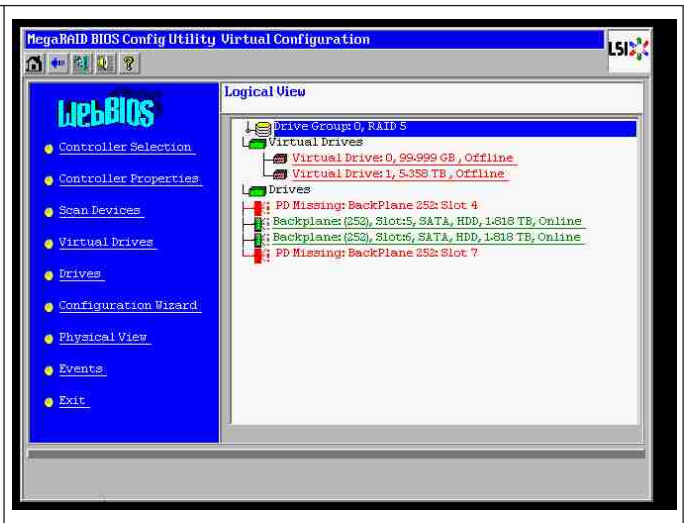
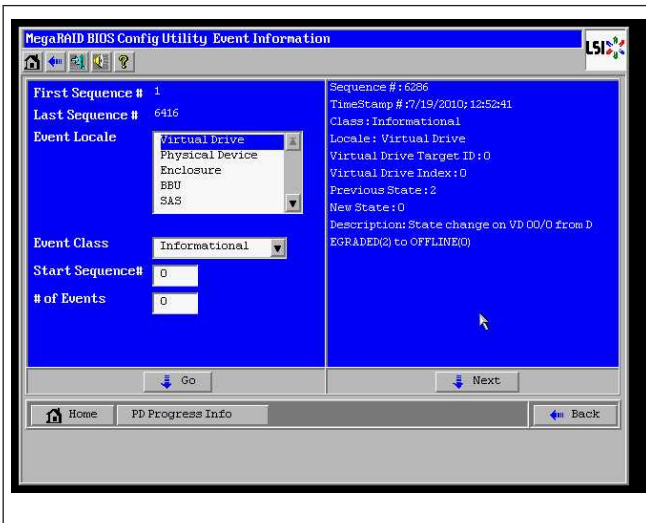

How to use the MegaCLI Command-Line Utility

Use a bootable DOS USB stick with XMS manager "himem.sys" and start the MegaCLI.exe. Please see the command reference in *MegaCLI Commandline Utility*, page 46.

The whole amount of log events can be seen with MegaCLI `-AdpAliLog -aAll > evt.txt`; but it takes a few minutes until the large file is written and it is too much information.

```

C:\LSIMEGA>MegaCli -AdpAliLog -aAll > evt.txt
DOS/32b -- Protected Mode Run-time Version 7.2
Copyright (C) Supernar Systems, Ltd. 1996-2002

C:\LSIMEGA>_

Alarm Enable           : Disabled
Disable AutoRebuild   : FALSE
Disable Battery Warning : TRUE
Restore Hotspare on Insertion : NO
Expose Enclosure Devices : NO

BBU Properties
-----
BBU Battery Type:                No Battery

Device Information
=====
Device Name:      ATA           Product Id:      WDC WD2003FYYS-
0                ATA           Product Id:      WDC WD2003FYYS-
0
Rev:              0B01          Vendor Specific: WD-WMAUR00
04599
Device Type:      DISK          Device ID:       5
SRS Address 0:    0x1221000050000000  SRS Address 1:  0x0
Media Error:      0             Other Error:     0
PredictiveFail:   0             Firmware State:  Online
Speed:            3.0Gb/s        DDF State:      SATA
Primary Defect:   ---            Grown Defect:   ---

```

For example, it is much better, to use this commands
(create with "-f ...txt" a file for analysis)

MegaCli -AdpEventLog -GetEvents -warning -f warning.txt -aALL

Adapter: 0 - Number of Events : 288

seqNum: 0x00001875

Time: Mon Jul 19 13:37:28 2010

Code: 0x00000124

Class: 1

Locale: 0x20

Event Description: Patrol Read can't be started, as PDs are either not ONLINE, or are in a VD with an active process, or are in an excluded VD

Event Data:

=====

None

seqNum: 0x0000188b

Time: Mon Jul 19 13:52:41 2010

Code: 0x00000070

Class: 1

Locale: 0x02

Event Description: Removed: PD 06(e0xfc/s6)

Event Data:

=====

Device ID: 6

Enclosure Index: 252

Slot Number: 6

MegaCli -AdpEventLog -GetEvents -critical -f critical.txt -aALL

Adapter: 0 - Number of Events : 288

seqNum: 0x00001893

Time: Mon Jul 19 13:52:41 2010

Code: 0x00000065
 Class: 2
 Locale: 0x02
 Event Description: Rebuild failed on PD 04(e0xfc/s4) due to source drive error
 Event Data:
 =====
 Device ID: 4
 Enclosure Index: 252
 Slot Number: 4

seqNum: 0x000018ba
 Time: Mon Jul 19 14:12:25 2010

Code: 0x000000fb
 Class: 2
 Locale: 0x01
 Event Description: VD 00/0 is now DEGRADED
 Event Data:
 =====
 Target Id: 0

seqNum: 0x000018bc
 Time: Mon Jul 19 14:12:25 2010

Code: 0x000000fb
 Class: 2
 Locale: 0x01
 Event Description: VD 01/1 is now DEGRADED
 Event Data:
 =====
 Target Id: 1

Useful commands:

MegaCli -AdpEventLog -GetEvents -info -f info.txt -aALL
 (but a large text file)

MegaCli -AdpEventLog -GetEvents -fatal -f fatal.txt -aALL

Adapter: 0 - Number of Events : 288 seqNum: 0x0000188f Time: Mon Jul 19 13:52:41 2010 Code: 0x000000fc Class: 3 Locale: 0x01 Event Description: VD 00/0 is now OFFLINE Event Data: ===== Target Id: 0	Adapter: 0 - Number of Events : 288 seqNum: 0x00001891 Time: Mon Jul 19 13:52:41 2010 Code: 0x000000fc Class: 3 Locale: 0x01 Event Description: VD 01/1 is now OFFLINE Event Data: ===== Target Id: 1
--	--

5.9.2 Multiple disks failed - practice

Press "C" to enter Utility. Click "start" and "scan disks".

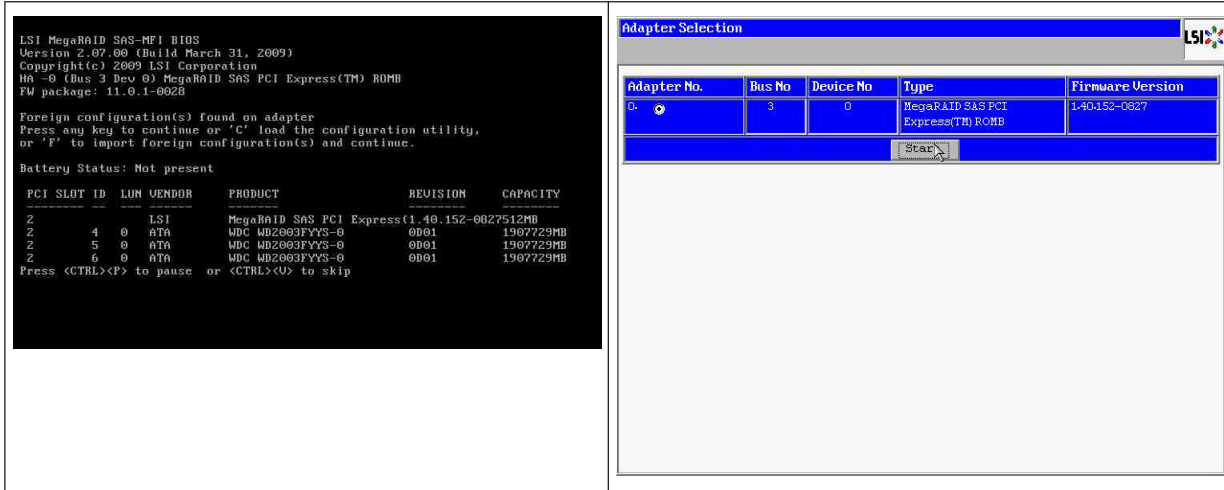

You get to the "foreign configuration import" screen.

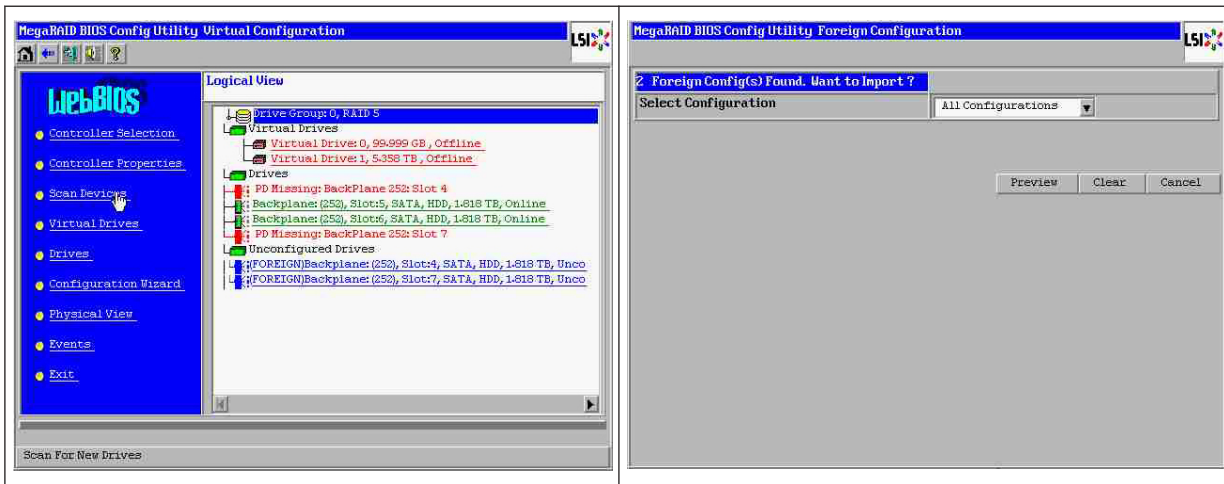

Select one of the two configurations and click **Preview**.

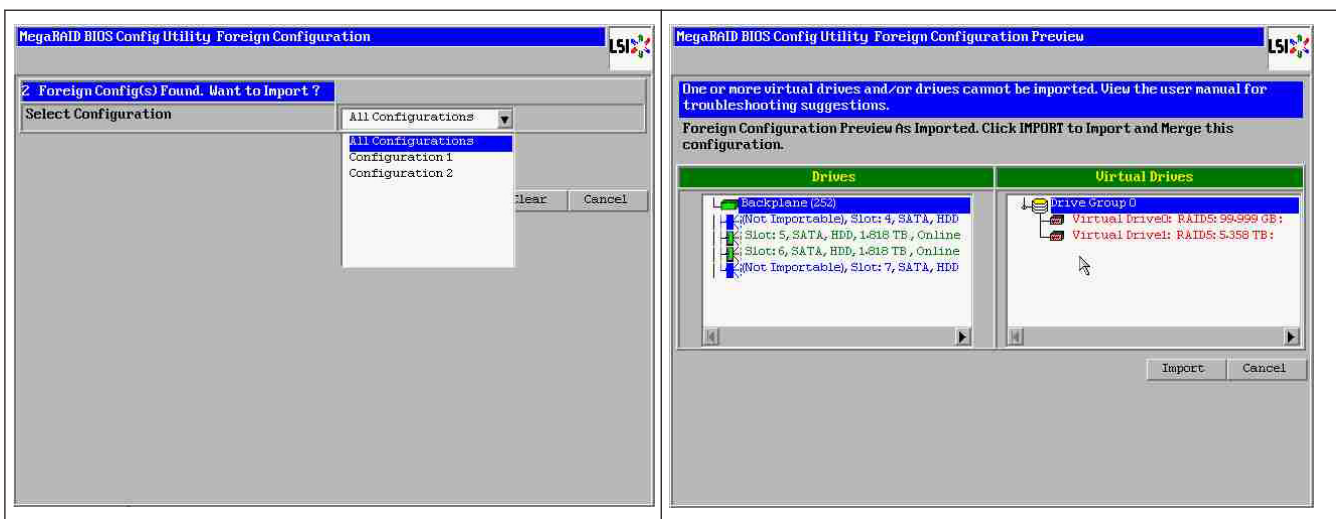

All disks are seen, but configuration is marked as not importable; click **Cancel** and view Configuration 2. It is the same; this means, a complex situation requires manual interaction.

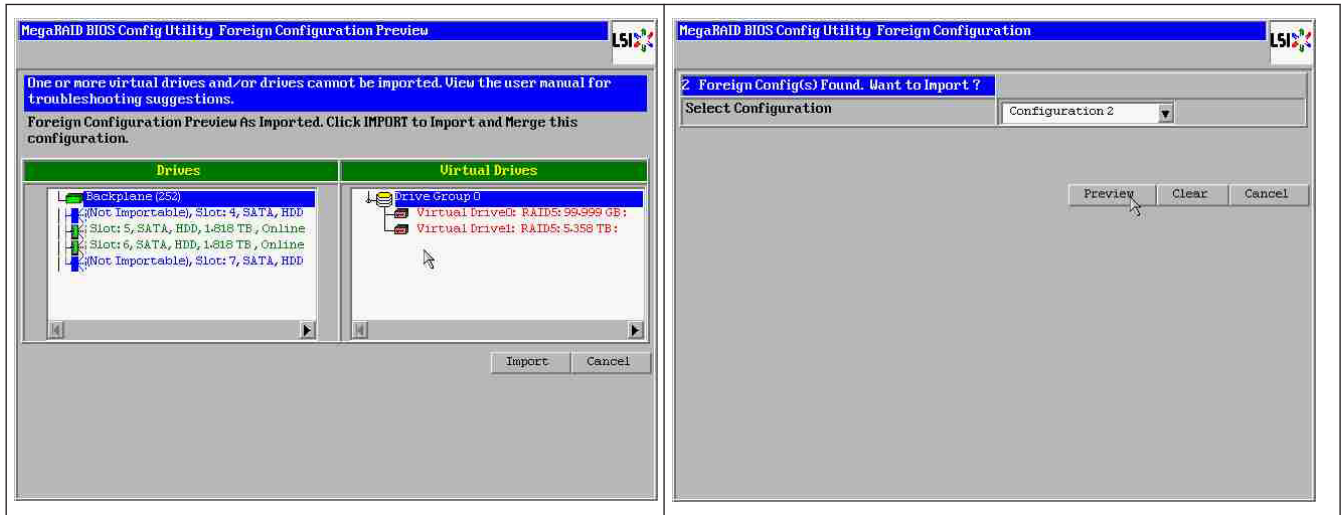

Click to clear all configurations, ignore the warning.

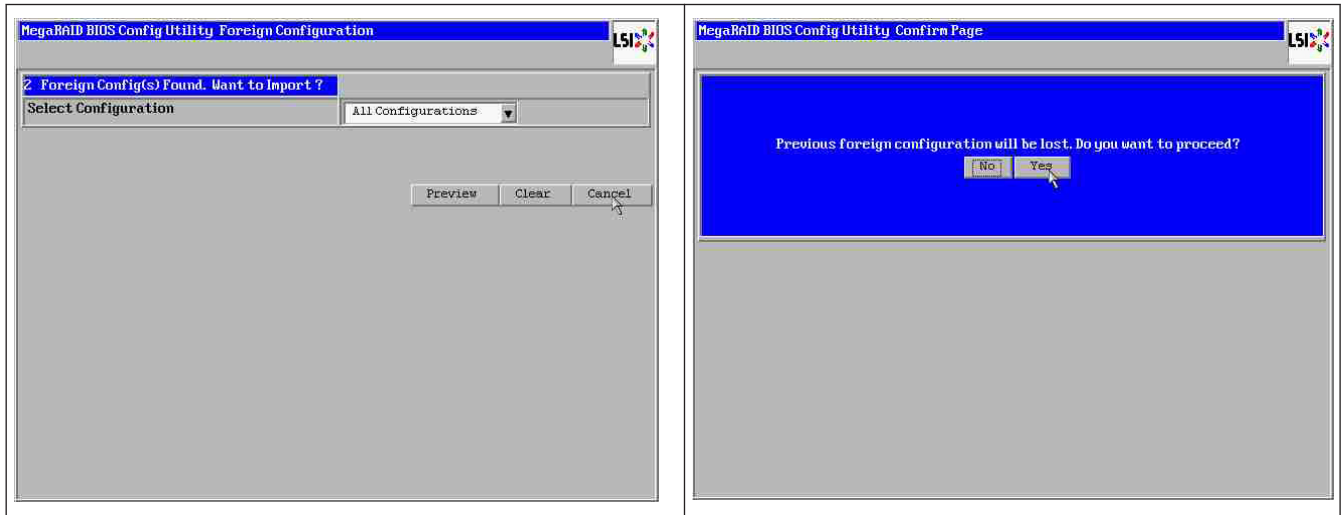

Before clear foreign configuration, 2 disks were missing, two were foreign. After clear, the foreign disks now are shown as unconfigured.

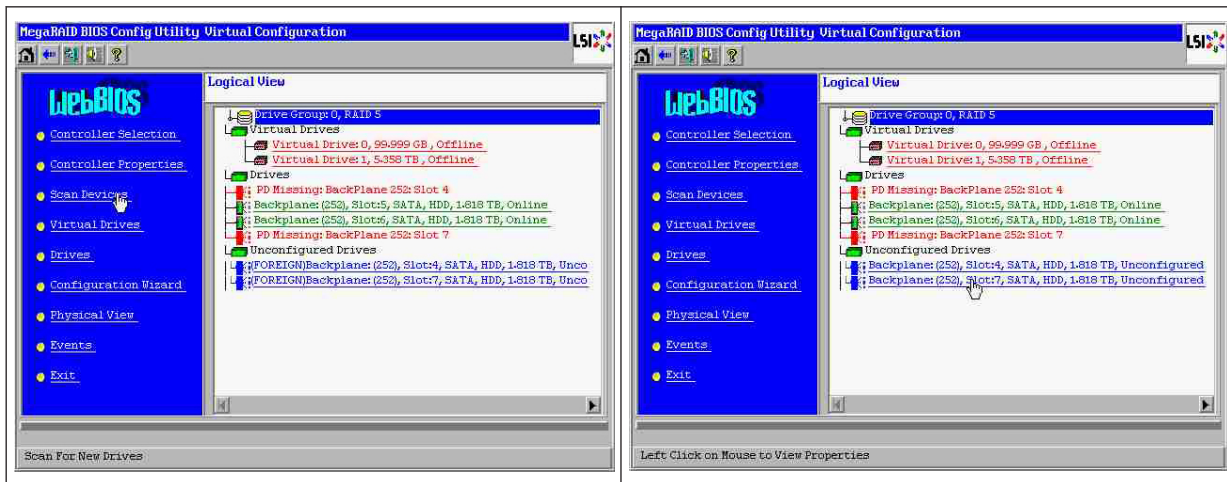

Use the event viewer or MegaCLI to identify the "first failed" disk.

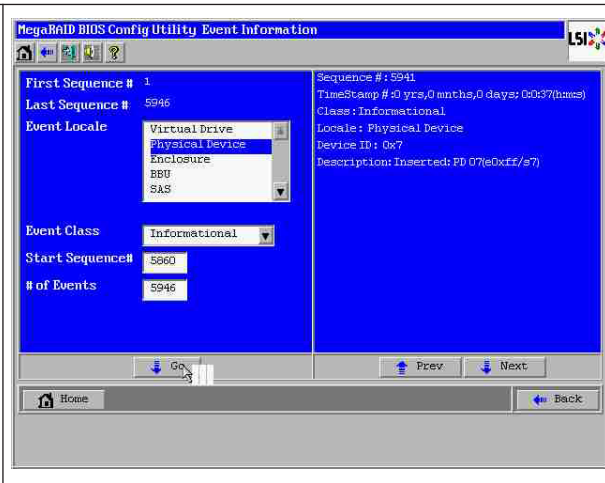

In this example, disk in Slot 4 was first fail, Slot 7 second fail. Click on "second fail" PD7 in the Logical View and you get in the Physical drive menu. Choose "replace missing PD" and the correct row for Slot 7 drive and click "go". Ignore the warning.

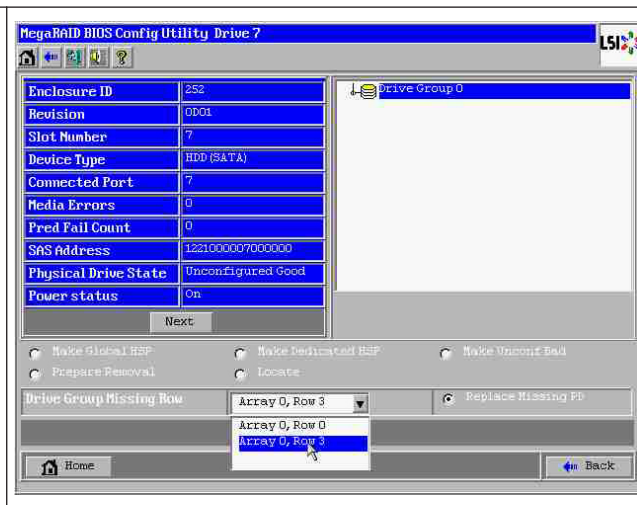
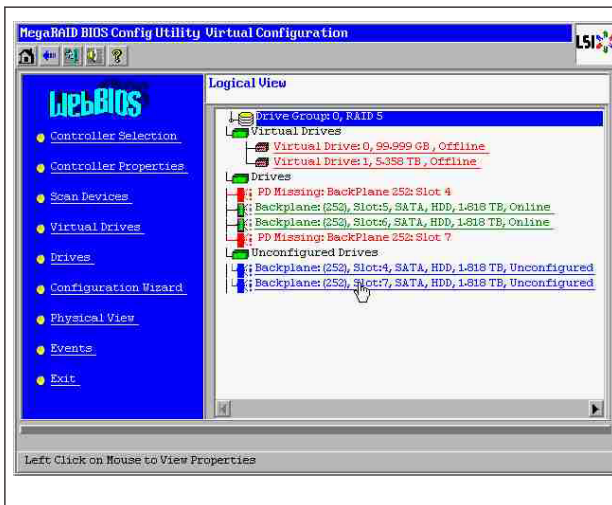

Now in Logical View we see this disk marked as offline; click on the disk to get in PD menu. Click on "Make online" and "go".

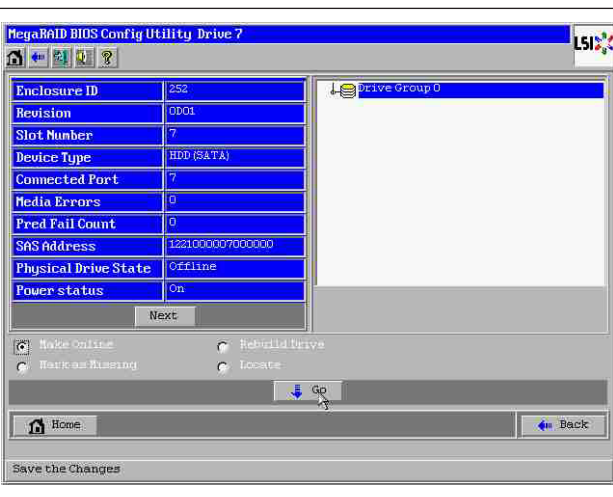
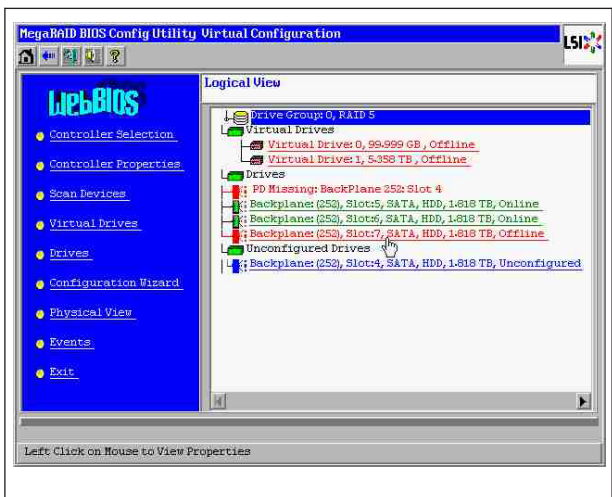

Now in logical view we see disk online and a degraded RAID. Click on disk 4 to get in the PD menu. Click on correct row, on "Global" or "dedicated Hot Spare" and on "go".

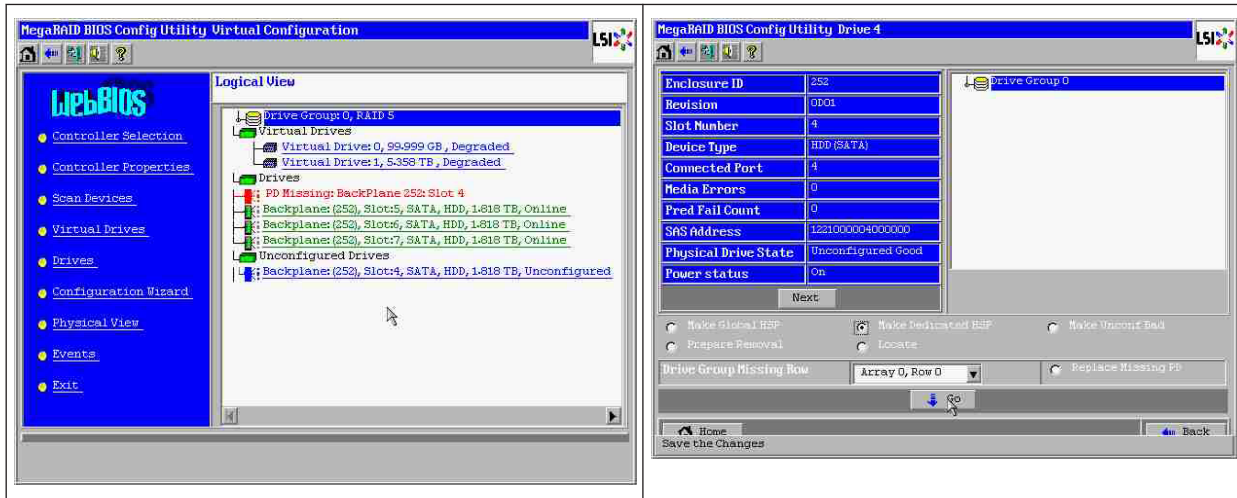

Click on home; in the Logical View, the rebuild is starting.

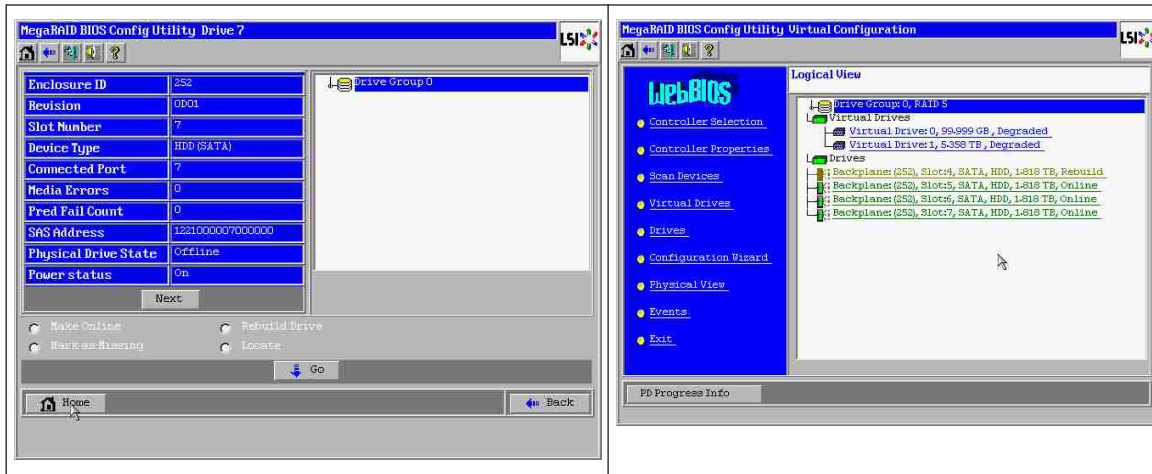

5.9.3 Foreign configuration disk appears in the Windows GUI after booting

The RAID is degraded. Topology error is shown. Right-click Megaraid Controller in the MSM GUI. Click "scan foreign configuration". In the next window, click "clear foreign configuration".

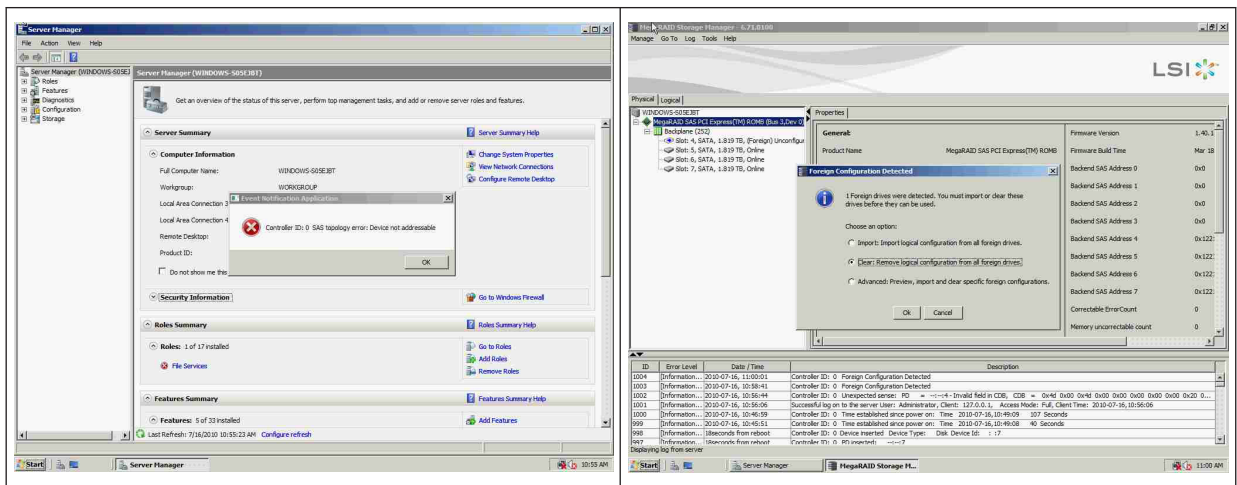

An unconfigured good drive is displayed. Right-click this drive and choose a hotspare type.

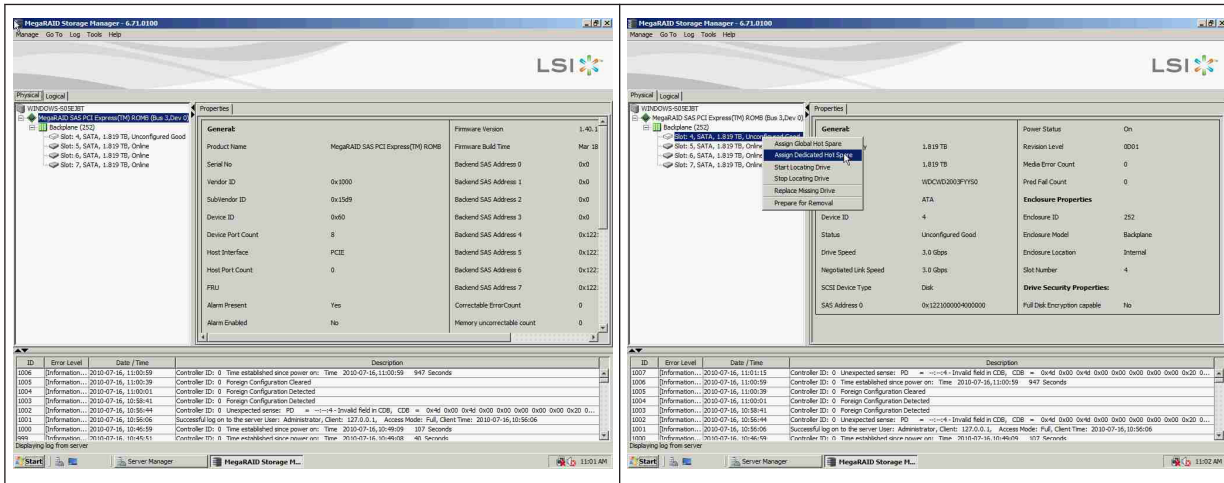

You see the rebuild is starting at once.

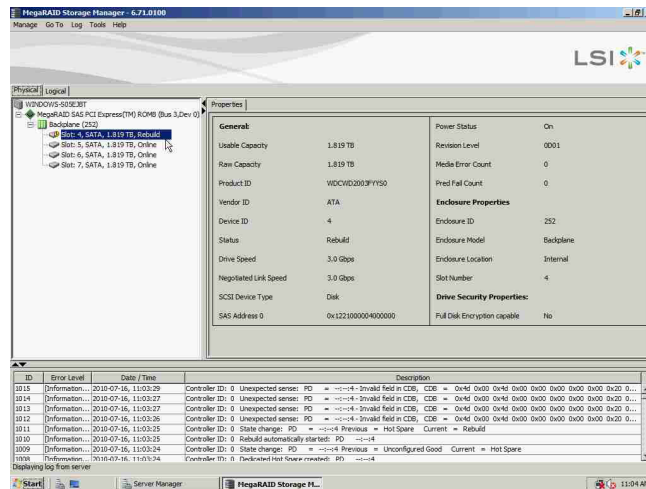

5.9.4

MegaCLI Commandline Utility

[-Silent] [-AppLogFile filename] [-NoLog] [-page [N]]
 [-] is optional.

N - Number of lines per page.

- MegaCli -v
- MegaCli -help|-h?
- MegaCli -adpCount
- MegaCli -AdpSetProp {CacheFlushInterval -val} | { RebuildRate -val}
- | {PatrolReadRate -val} | {BgiRate -val} | {CCRate -val}
- | {ReconRate -val} | {SpinupDriveCount -val} | {SpinupDelay -val}
- | {CoercionMode -val} | {ClusterEnable -val} | {PredFailPollInterval -val}
- | {BatWarnDsbl -val} | {EccBucketSize -val} | {EccBucketLeakRate -val}
- | {AbortCCOnError -val} | AlarmEnbl | AlarmDsbl | AlarmSilence
- | {SMARTCpyBkEnbl -val} | {SSDSMARTCpyBkEnbl -val} | NCQEnbl | NCQDsbl
- | {MaintainPdFailHistoryEnbl -val} | {RstrHotSpareOnInsert -val}
- | {EnblSpinDownUnConfigDrvs -val} | {EnblSSDPatrolRead -val}
- | {DisableOCR -val} | {BootWithPinnedCache -val}
- | AutoEnhancedImportEnbl | AutoEnhancedImportDsbl -aN|-a0,1,2|-aALL
- | {ExposeEnclDevicesEnbl -val} -aN|-a0,1,2|-aALL

```

| {DsbISpinDownHsp -val} -aN|-a0,1,2|-aALL
| {SpinDownTime -val} -aN|-a0,1,2|-aALL
MegaCli -AdpSetProp -AutoDetectBackPlaneDsbl -val -aN|-a0,1,2|-aALL
val - 0=Enable Auto Detect of SGPIO and i2c SEP.
1=Disable Auto Detect of SGPIO.
2=Disable Auto Detect of i2c SEP.
3=Disable Auto Detect of SGPIO and i2c SEP.
MegaCli -AdpSetProp -CopyBackDsbl -val -aN|-a0,1,2|-aALL
val - 0=Enable Copyback.
1=Disable Copyback.
MegaCli -AdpSetProp -EnableJBOD -val -aN|-a0,1,2|-aALL
val - 0=Disable JBOD mode.
1=Enable JBOD mode.
MegaCli -AdpSetProp -DsbICacheBypass -val -aN|-a0,1,2|-aALL
val - 0=Enable Cache Bypass.
1=Disable Cache Bypass.
MegaCli -AdpSetProp -LoadBalanceMode -val -aN|-a0,1,2|-aALL
val - 0=Auto Load balance mode.
1=Disable Load balance mode.
MegaCli -AdpSetProp -UseFDEOnlyEncrypt -val -aN|-a0,1,2|-aALL
val - 0=FDE and controller encryption (if HW supports) is allowed.
1=Only support FDE encryption, disallow controller encryption.
MegaCli -AdpSetProp -PrCorrectUncfgdAreas -val -aN|-a0,1,2|-aALL
val - 0= Correcting Media error during PR is disabled.
1=Correcting Media error during PR is allowed.
MegaCli -AdpSetProp -DsbISpinDownHSP -val -aN|-a0,1,2|-aALL
val - 0= Spinning down the Hot Spare is enabled.
1=Spinning down the Hot Spare is disabled.
MegaCli -AdpGetProp CacheFlushInterval | RebuildRate | PatrolReadRate
| BgiRate | CCRate | ReconRate | SpinupDriveCount | SpinupDelay
| CoercionMode | ClusterEnable | PredFailPollInterval | BatWarnDsbl
| EccBucketSize | EccBucketLeakRate | EccBucketCount | AbortCCOnError
| AlarmDsply | SMARTCpyBkEnbl | SSDSMARTCpyBkEnbl | NCQDsply
| MaintainPdFailHistoryEnbl | RstrHotSpareOnInsert
| EnblSpinDownUnConfigDrvs | EnblSSDPatrolRead | DisableOCR
| BootWithPinnedCache | AutoEnhancedImportDsply | AutoDetectBackPlaneDsbl
| CopyBackDsbl | LoadBalanceMode | UseFDEOnlyEncrypt | WBSupport | EnableJBOD
| DsbICacheBypass | ExposeEnclDevicesEnbl | DsbISpinDownHsp | SpinDownTime
| PrCorrectUncfgdAreas -aN|-a0,1,2|-aALL
| DsbISpinDownHSP -aN|-a0,1,2|-aALL
MegaCli -AdpAllInfo -aN|-a0,1,2|-aALL
MegaCli -AdpGetTime -aN|-a0,1,2|-aALL
MegaCli -AdpSetTime yyyyymmdd hh:mm:ss -aN
MegaCli -AdpSetVerify -f fileName -aN|-a0,1,2|-aALL
MegaCli -AdpBIOS -Enbl |-DsbI |-SOE |-BE |-Dsply -aN|-a0,1,2|-aALL
MegaCli -AdpBootDrive {-Set {-Lx | -physdrv[E0:S0]}}-Get -aN|-a0,1,2|-aALL
MegaCli -AdpAutoRbld -Enbl|-DsbI|-Dsply -aN|-a0,1,2|-aALL
MegaCli -AdpCacheFlush -aN|-a0,1,2|-aALL
MegaCli -AdpPR -DsbI|EnblAuto|EnblMan|Start|Stop|Info| SSDPatrolReadEnbl |
SSDPatrolReadDsbl

```

```

|{SetDelay Val}|{-SetStartTime yyyyymmdd hh}|{maxConcurrentPD Val} -aN|-a0,1,2|-aALL
MegaCli -AdpCcSched -Dsbl|-Info|{-ModeConc | -ModeSeq [-ExcludeLD -LN|-L0,1,2]
[-SetStartTime yyyyymmdd hh ] [-SetDelay val ] } -aN|-a0,1,2|-aALL
MegaCli -AdpCcSched -SetStartTime yyyyymmdd hh -aN|-a0,1,2|-aALL
MegaCli -AdpCcSched -SetDelay val -aN|-a0,1,2|-aALL
MegaCli -FwTermLog -BBUoff|BBUoffTemp|BBUon|Dsply|Clear -aN|-a0,1,2|-aALL
MegaCli -AdpAllLog -aN|-a0,1,2|-aALL
MegaCli -AdpDiag [val] -aN|-a0,1,2|-aALL
val - Time in second.
MegaCli -AdpBatTest -aN|-a0,1,2|-aALL
MegaCli -PDList -aN|-a0,1,2|-aALL
MegaCli -PDGetNum -aN|-a0,1,2|-aALL
MegaCli -pdInfo -PhysDrv[E0:S0,E1:S1,...] -aN|-a0,1,2|-aALL
MegaCli -PDOnline -PhysDrv[E0:S0,E1:S1,...] -aN|-a0,1,2|-aALL
MegaCli -PDOffline -PhysDrv[E0:S0,E1:S1,...] -aN|-a0,1,2|-aALL
MegaCli -PDMakeGood -PhysDrv[E0:S0,E1:S1,...] | [-Force] -aN|-a0,1,2|-aALL
MegaCli -PDMakeJBOD -PhysDrv[E0:S0,E1:S1,...] -aN|-a0,1,2|-aALL
MegaCli -PDHSP {-Set [-Dedicated [-ArrayN|-Array0,1,2,...]] [-EnclAffinity] [-nonRevertible]}
|-Rmv -PhysDrv[E0:S0,E1:S1,...] -aN|-a0,1,2|-aALL
MegaCli -PDRbld -Start|-Stop|-ShowProg |-ProgDsply
-PhysDrv [E0:S0,E1:S1,...] -aN|-a0,1,2|-aALL
MegaCli -PDClear -Start|-Stop|-ShowProg |-ProgDsply
-PhysDrv [E0:S0,E1:S1,...] -aN|-a0,1,2|-aALL
MegaCli -PdLocate {[-Start] | -stop } -physdrv[E0:S0,E1:S1,...] -aN|-a0,1,2|-aALL
MegaCli -PdMarkMissing -physdrv[E0:S0,E1:S1,...] -aN|-a0,1,2|-aALL
MegaCli -PdGetMissing -aN|-a0,1,2|-aALL
MegaCli -PdReplaceMissing -physdrv[E0:S0] -arrayA, -rowB -aN
MegaCli -PdPrpRmv [-UnDo] -physdrv[E0:S0] -aN|-a0,1,2|-aALL
MegaCli -EncInfo -aN|-a0,1,2|-aALL
MegaCli -EncStatus -aN|-a0,1,2|-aALL
MegaCli -PhyInfo -phyM -aN|-a0,1,2|-aALL
MegaCli -LDInfo -Lx|-L0,1,2|-Lall -aN|-a0,1,2|-aALL
MegaCli -LDSetProp {-Name LdNamestring} | -RW|RO|Blocked | WT|WB [-Immediate]]|RA|NORA|
ADRA
| Cached|Direct | -EnDskCache|DisDskCache | CachedBadBBU|NoCachedBadBBU
-Lx|-L0,1,2|-Lall -aN|-a0,1,2|-aALL
MegaCli -LDGetProp -Cache | -Access | -Name | -DskCache -Lx|-L0,1,2|-LALL
-aN|-a0,1,2|-aALL
MegaCli -getLdExpansionInfo -Lx|-L0,1,2|-Lall -aN|-a0,1,2|-aALL
MegaCli -LdExpansion -pN -dontExpandArray -Lx|-L0,1,2|-Lall -aN|-a0,1,2|-aALL
MegaCli -LDInit {-Start [-full]]|-Abort|-ShowProg|-ProgDsply -Lx|-L0,1,2|-LALL -aN|-a0,1,2|-aALL
MegaCli -LDCC {-Start [-force]]|-Abort|-ShowProg|-ProgDsply -Lx|-L0,1,2|-LALL -aN|-a0,1,2|-
aALL
MegaCli -LDBI -Enbl|-Dsbl|-getSetting|-Abort|-ShowProg|-ProgDsply -Lx|-L0,1,2|-LALL -aN|-
a0,1,2|-aALL
MegaCli -LDRecon {-Start -rX [{-Add | -Rmv} -Physdrv[E0:S0,...]]|-ShowProg|-ProgDsply
-Lx -aN
MegaCli -LdPdInfo -aN|-a0,1,2|-aALL
MegaCli -LDGetNum -aN|-a0,1,2|-aALL
MegaCli -LDBBMClr -Lx|-L0,1,2,...|-Lall -aN|-a0,1,2|-aALL

```



```

MegaCli -CfgLdAdd -rX[E0:S0,E1:S1,...] [WT|WB] [NORA|RA|ADRA] [Direct|Cached]
[CachedBadBBU|NoCachedBadBBU] [-szXXX [-szYYY ...]]
[-strpszM] [-Hsp[E0:S0,...]] [-AfterLdX] [-Force][FDE|CtrlBased] -aN
MegaCli -CfgSscdAdd -Physdrv[E0:S0,...] {-Name LdNamestring} -aN|-a0,1,2|-aALL
MegaCli -CfgEachDskRaid0 [WT|WB] [NORA|RA|ADRA] [Direct|Cached]
[CachedBadBBU|NoCachedBadBBU] [-strpszM][FDE|CtrlBased] -aN|-a0,1,2|-aALL
MegaCli -CfgClr -aN|-a0,1,2|-aALL
MegaCli -CfgDsply -aN|-a0,1,2|-aALL
MegaCli -CfgLdDel -LX|-L0,2,5...|-LALL -aN|-a0,1,2|-aALL
MegaCli -CfgSscdDel -LX|-L0,2,5...|-LALL -aN|-a0,1,2|-aALL
MegaCli -CfgFreeSpaceinfo -aN|-a0,1,2|-aALL
MegaCli -CfgSpanAdd -r10 -Array0[E0:S0,E1:S1] -Array1[E0:S0,E1:S1] [-
ArrayX[E0:S0,E1:S1] ...] -aN
MegaCli -CfgSpanAdd -r50 -Array0[E0:S0,E1:S1,E2:S2,...] -Array1[E0:S0,E1:S1,E2:S2,...]
[-ArrayX[E0:S0,E1:S1,E2:S2,...] ...] [WT|WB] [NORA|RA|ADRA] [Direct|Cached]
[CachedBadBBU|NoCachedBadBBU] [-strpszM] [-szXXX [-szYYY ...]][-AfterLdX]
[FDE|CtrlBased] -aN
MegaCli -CfgAllFreeDrv -rX [-SATAOnly] [-SpanCount XXX] [WT|WB] [NORA|RA|ADRA]
[Direct|Cached] [CachedBadBBU|NoCachedBadBBU] [-strpszM]
[-HspCount XX [-HspType -Dedicated|-EnclAffinity|-nonRevertible]] |
[FDE|CtrlBased] -aN
MegaCli -CfgSave -f filename -aN
MegaCli -CfgRestore -f filename -aN
MegaCli -CfgForeign -Scan | [-SecurityKey ssssssssss] -aN|-a0,1,2|-aALL
MegaCli -CfgForeign -Dsply [x] | [-SecurityKey ssssssssss] -aN|-a0,1,2|-aALL
MegaCli -CfgForeign -Preview [x] | [-SecurityKey ssssssssss] -aN|-a0,1,2|-aALL
MegaCli -CfgForeign -Import [x] | [-SecurityKey ssssssssss] -aN|-a0,1,2|-aALL
MegaCli -CfgForeign -Clear [x][[-SecurityKey ssssssssss] -aN|-a0,1,2|-aALL
x - index of foreign configurations. Optional. All by default.
MegaCli -AdpEventLog -GetEventLogInfo -aN|-a0,1,2|-aALL
MegaCli -AdpEventLog -GetEvents {-info -warning -critical -fatal} {-f <fileName>} -aN|-a0,1,2|-
aALL
MegaCli -AdpEventLog -GetSinceShutdown {-info -warning -critical -fatal} {-f <fileName>} -aN|-
a0,1,2|-aALL
MegaCli -AdpEventLog -GetSinceReboot {-info -warning -critical -fatal} {-f <fileName>} -aN|-
a0,1,2|-aALL
MegaCli -AdpEventLog -IncludeDeleted {-info -warning -critical -fatal} {-f <fileName>} -aN|-
a0,1,2|-aALL
MegaCli -AdpEventLog -GetLatest n {-info -warning -critical -fatal} {-f <fileName>} -aN|-a0,1,2|-
aALL
MegaCli -AdpEventLog -GetCCIncon -f <fileName> -LX|-L0,2,5...|-LALL -aN|-a0,1,2|-aALL
MegaCli -AdpEventLog -Clear -aN|-a0,1,2|-aALL
MegaCli -AdpBbuCmd -aN|-a0,1,2|-aALL
MegaCli -AdpBbuCmd -GetBbuStatus -aN|-a0,1,2|-aALL
MegaCli -AdpBbuCmd -GetBbuCapacityInfo -aN|-a0,1,2|-aALL
MegaCli -AdpBbuCmd -GetBbuDesignInfo -aN|-a0,1,2|-aALL
MegaCli -AdpBbuCmd -GetBbuProperties -aN|-a0,1,2|-aALL
MegaCli -AdpBbuCmd -BbuLearn -aN|-a0,1,2|-aALL
MegaCli -AdpBbuCmd -BbuMfgSleep -aN|-a0,1,2|-aALL
MegaCli -AdpBbuCmd -BbuMfgSeal -aN|-a0,1,2|-aALL

```

```

MegaCli -AdpBbuCmd -SetBbuProperties -f <fileName> -aN|-a0,1,2|-aALL
MegaCli -AdpFacDefSet -aN
MegaCli -AdpM0Flash -f filename
MegaCli -AdpGetConnectorMode -ConnectorN|-Connector0,1|-ConnectorAll -aN|-a0,1,2|-aALL
MegaCli -AdpSetConnectorMode -Internal|-External|-Auto -ConnectorN|-Connector0,1|-
ConnectorAll -aN|-a0,1,2|-aALL
MegaCli -PhyErrorCounters -aN|-a0,1,2|-aALL
MegaCli -DirectPdMapping -Enbl|-Dsb|-Dsply -aN|-a0,1,2|-aALL
MegaCli -ShowEnclList -aN|-a0,1,2|-aALL
MegaCli -ShowVpd -Page N -Encl N -aN|-a0,1,2|-aALL
MegaCli -EnclLocate -Start|-Stop -Encl N -aN|-a0,1,2|-aALL
MegaCli -EnclFwDownload -Encl N -Esm A|B -f <filename> -aN|-a0,1,2|-aALL
MegaCli -PdFwDownload [-SataBridge] -PhysDrv[0:1,1:2,...] -f <filename> -aN|-a0,1,2|-aALL
MegaCli -SetFacDefault -Encl N -Esm A|B -f <filename> -aN|-a0,1,2|-aALL
MegaCli -PDCpyBk -Start -PhysDrv[E0:S0,E1:S1] -aN|-a0,1,2|-aALL
MegaCli -PDCpyBk -Stop|-ShowProg|-ProgDsply -PhysDrv[E0:S0] -aN|-a0,1,2|-aALL
MegaCli -PDInstantSecureErase -PhysDrv[E0:S0,E1:S1,...] | [-Force] -aN|-a0,1,2|-aALL
MegaCli -LDMakeSecure -Lx|-L0,1,2,...|-Lall -aN|-a0,1,2|-aALL
MegaCli -DestroySecurityKey | [-Force] -aN
MegaCli -CreateSecurityKey -SecurityKey ssssssssss | [-Passphrase ssssssssss] [[-KeyID
kkkkkkkkkk] -aN
MegaCli -ChangeSecurityKey -OldSecurityKey ssssssssss | -SecurityKey ssssssssss|
[-Passphrase ssssssssss] | [-KeyID kkkkkkkkkk] -aN
MegaCli -GetKeyID [-PhysDrv[E0:S0]] -aN
MegaCli -SetKeyID -KeyID kkkkkkkkkk -aN
MegaCli -VerifySecurityKey -SecurityKey ssssssssss -aN

```

ssssssssss - It must be between eight and thirty-two characters and contain at least one number, one lowercase letter, one uppercase letter and one non-alphanumeric character.

kkkkkkkkkk - Must be less than 256 characters.

```
MegaCli -GetPreservedCacheList -aN|-a0,1,2|-aALL
```

```
MegaCli -DiscardPreservedCache -Lx|-L0,1,2|-Lall -aN|-a0,1,2|-aALL
```

```
MegaCli -AdpInfoCompare {-checkFw <string> | -checkID -hex | -checkBatt -val | -checkDimm -
val} -aN|-a0,1,2|-aALL
```

```
MegaCli -adpFwDump
```

```
MegaCli -AdpNameRtn -aN|-a0,1,2|-aALL
```

ssssssssss - It must be between eight and thirty-two characters and contain at least one number, one lowercase letter, one uppercase letter and one non-alphanumeric character.

kkkkkkkkkk - Must be less than 256 characters.

```
MegaCli -ShowSummary [-f filename] -aN
```

Note: The directly connected drives can be specified as [:S]

Wildcard '?' can be used to specify the enclosure ID for the drive in the only enclosure without direct connected device or the direct connected

drives with no enclosure in the system.

Note:[-aALL] option assumes that the parameters specified are valid for all the Adapters.

The following options may be given at the end of any command above:

[-Silent] [-AppLogFile filename] [-NoLog] [-page [N]]

[-] is optional.

N - Number of lines per page.

Exit Code: 0x00

Bosch Sicherheitssysteme GmbH

Robert-Bosch-Ring 5

85630 Grasbrunn

Germany

www.boschsecurity.com

© Bosch Sicherheitssysteme GmbH, 2013