

MIC Series Power Supplies (Standard)

www.boschsecurity.com



BOSCH
Invented for life



- ▶ Provide all connections for power, telemetry and video for the MIC series of PTZ cameras.
- ▶ Weather-resistant, cast-aluminum IP65 enclosure with weather-proof, ½ in. NPT, M16, and M12 cable glands.
- ▶ MIC-24PSU-2, MIC-115PSU-2, and MIC-240PSU-2 models have dual video outputs.
- ▶ Integrated header for addition of ancillary cards such as the MIC alarm card, washer pump drive card or bi-phase converter card.
- ▶ Ground isolation and termination to control video grounding and to prevent ground loops.

A full range of MIC Series power supply units (PSUs) from Bosch Security Systems provides all connections for power, telemetry and video for the MIC series range of PTZ cameras. These PSUs ensure that MIC cameras can be installed in a variety of locations, including low voltage and mobile applications. Each power supply has UL, CE, and FCC approval, is rated to IP65, supports 50/60 Hz, and comes in a selection of input voltages. The PSU housing also has slots for optional cards, such as the 8-channel alarm card including washer pump drive (MIC-ALM).

System Overview

Certifications and Approvals

Electromagnetic Compatibility (EMC)	Complies with FCC Part 15 and ICES-003 regulations
Product Safety	Complies with UL (UL 2044), CSA Standards (CSA Standard C22.2 No. 1-98), and CE
Ingress Protection Rating	IP65

Region	Certification	
USA	FCC	CFR 47 FCC Part 15:2009 Class B
	UL	60950-1, 2nd Edition:2007
Canada	CSA	CAN/CSA-22.2-No. 60950-1-07
Europe	CE	EC Declaration of Conformity

Installation/Configuration Notes

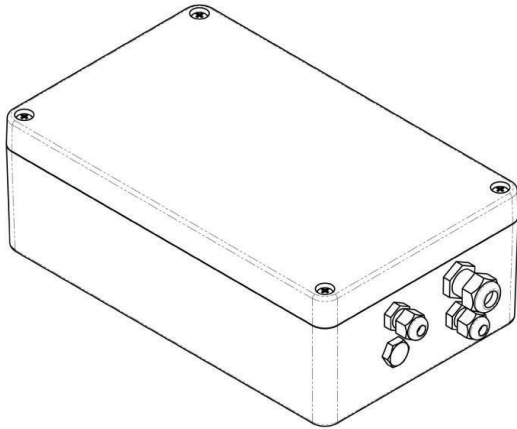

Power Supply Box – full view

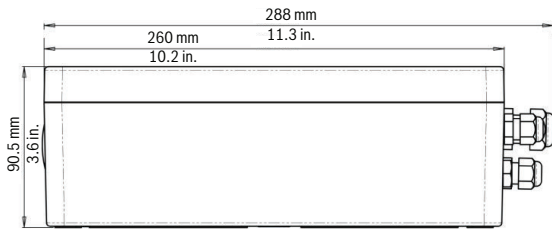

Power Supply Box – side view

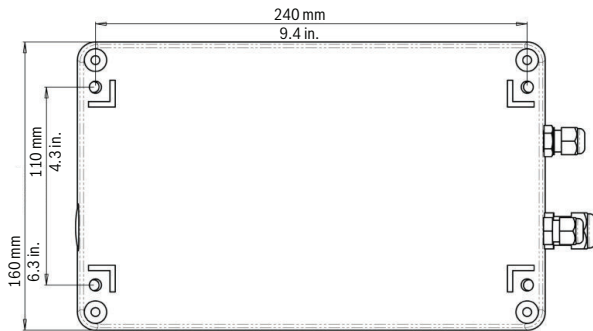

Power Supply Box – bottom view

Technical Specifications

Electrical

Model	Voltage / Power @ 50/60 Hz	Applicable Cameras
Non-IR Power Supply Units		
MIC-24PSU-2	Input: 24 VAC / 40 VA Output: 18 VAC	MIC400ST, MIC440, MIC550, MIC612 (Legacy: MIC400AL, MIC412, MIC500)
MIC-115PSU-2	Input: 115 VAC / 40 VA Output: 18 VAC	
MIC-240PSU-2	Input: 230 VAC / 40 VA Output: 18 VAC	
IR Power Supply Units		
MIC-IR-24-PSU-UL	Input: 24 VAC / 60 VA Output: 18 VAC	MIC550IR (Legacy: MIC400IR)
MIC-IR-114PSU-UL	Input: 115 VAC / 60 VA Output: 18 VAC	
MIC-IR-240PSU-UL	Input: 230 VAC / 60 VA Output: 18 VAC	

Mechanical

Dimensions (H x W D)	
• Enclosure	90 x 160 x 260 mm (3.54 x 6.3 x 10.24 in.)
• With glands	90 x 160 x 288 mm (3.54 x 6.3 x 11.34 in.)
Form Factor (four screw holes)	110 x 240 mm (4.3 x 9.4 in.)
Weight	Non-IR PSUs: 3.24 kg (7.14 lb) IR PSUs: 3.75 kg (8.27 lb)
Material	Powder-coated cast-aluminum, rated IP65
Color	RAL 9010 (Pure White)
Options	MIC-ALM (8-input alarm card) MIC-WKT (washer pump kit) MIC-WKT-IR (washer pump kit for IR models) MIC-BP3 (Biphase card) MIC-BP4 (Biphase card)

Environmental

Operating Temperature	-40 °C to +60 °C (-40 °F to +140 °F)
Storage Temperature	-40 °C to +65 °C (-40 °F to +149 °F)

Ordering Information

MIC-24PSU-2 MIC Power Supply Unit, 24VAC, 50/60 Hz
24 VAC, 50/60 Hz power supply with two video outputs for MIC Series cameras.
Order number **MIC-24PSU-2**

MIC-115PSU-2 MIC Power Supply Unit, 120VAC, 50/60 Hz
115 VAC, 50/60 Hz power supply with two video outputs for MIC Series cameras.
Order number **MIC-115PSU-2**

MIC-240PSU-2 MIC Power Supply Unit, 230 VAC, 50/60 HZ
230 VAC, 50/60 Hz power supply with two video outputs for MIC Series cameras.
Order number **MIC-240PSU-2**

MIC-IR-24PSU-UL 24 VAC Camera/IR Power Supply
24 VAC, 50/60 Hz power supply for MIC Series cameras with Infrared Illuminators
Order number **MIC-IR-24PSU-UL**

MIC-IR-115PSU-UL 115 VAC Camera/IR Power Supply
115 VAC, 50/60 Hz power supply for MIC Series cameras with Infrared Illuminators
Order number **MIC-IR-115PSU-UL**

MIC-IR-240PSU-UL 240 VAC Camera/IR Power Supply
230 VAC, 50/60 Hz power supply for MIC Series cameras Infrared Illuminators
Order number **MIC-IR-240PSU-UL**

Accessories

MIC-2M-S Composite Cable
2 m composite cable with plug for power, data and video
Order number **MIC-2M**

MIC-10M-S Composite Cable
10 m composite cable with plug for power, data and video
Order number **MIC-10M**

MIC-20M-S Composite Cable
20 m composite cable with plug for power, data and video
Order number **MIC-20M**

MIC-25M-S Composite Cable
25 m composite cable with plug for power, data and video
Order number **MIC-25M**

MIC-THERCBL-2M MIC 2M Composite Cable for Thermal Cameras
Order number **MIC-THERCBL-2M**

MIC-THERCBL-10M MIC 10M Composite Cable for Thermal Cameras
Order number **MIC-THERCBL-10M**

MIC-THERCBL-20M MIC 20M Composite Cable for Thermal Cameras
Order number **MIC-THERCBL-20M**

MIC-THERCLB-25M MIC 25M Composite Cable for Thermal Cameras
Order number **MIC-THERCBL-25M**

MIC-BP3 Biphase Converter
Biphase converter for IR power supplies or non-IR power supplies without a free expansion slot available
Order number **MIC-BP3**

MIC-BP4 Biphase Converter
Biphase converter for non-IR versions of MIC series power supply units
Order number **MIC-BP4**

MIC-ALM Alarm and Washer Pump Drive Card
8 Input alarm and washer pump drive card for PSU (Not for IR PSU)
Order number **MIC-ALM**

MIC-WKT Washer Kit
Washer kit for non infrared MIC models (includes washer pump drive card, washer nozzle and mounting brackets for wall and 4 in. PCD base)
Order number **MIC-WKT**

MIC-WKT-IR Washer Kit
Washer kit for infrared power supplies only (includes washer nozzle and mounting brackets for wall or 4 in. PCD base)
Order number **MIC-WKT-IR**

Represented by:

Americas:

Bosch Security Systems, Inc.
130 Perinton Parkway
Fairport, New York, 14450, USA
Phone: +1 800 289 0096
Fax: +1 585 223 9180
security.sales@us.bosch.com
www.boschsecurity.us

Europe, Middle East, Africa:

Bosch Security Systems B.V.
P.O. Box 80002
5617 BA Eindhoven, The Netherlands
Phone: + 31 40 2577 284
Fax: +31 40 2577 330
emea.securitysystems@bosch.com
www.boschsecurity.com

Asia-Pacific:

Robert Bosch (SEA) Pte Ltd, Security
Systems
11 Bishan Street 21
Singapore 573943
Phone: +65 6571 2808
Fax: +65 6571 2699
apr.securitysystems@bosch.com
www.boschsecurity.asia

China:

Bosch (Shanghai) Security Systems Ltd.
201 Building, No. 333 Fuquan Road
North IBP
Changning District, Shanghai
200335 China
Phone +86 21 22181111
Fax: +86 21 22182398
www.boschsecurity.com.cn

America Latina:

Robert Bosch Ltda Security Systems Division
Via Anhanguera, Km 98
CEP 13065-900
Campinas, Sao Paulo, Brazil
Phone: +55 19 2103 2860
Fax: +55 19 2103 2862
al.securitysystems@bosch.com
www.boschsecurity.com